

NATIONAL HISTORIC PARKS
AND SITES BRANCH

DIRECTION DES LIEUX ET DES
PARCS HISTORIQUES NATIONAUX

MANUSCRIPT REPORT NUMBER
TRAVAIL INÉDIT NUMÉRO **210**

FORT RODD HILL:
A STRUCTURAL HISTORY OF UPPER BATTERY
AND LOWER BATTERY

by
JOSEPH GREENOUGH

(1977)

PARKS CANADA
DEPARTMENT OF INDIAN
AND NORTHERN AFFAIRS

PARCS CANADA
MINISTÈRE DES AFFAIRES
INDIENNES ET DU NORD

Fort Rodd Hill:
A Structural History of Upper Battery
and Lower Battery
by Joseph Greenough
1977

The Manuscript Report Series is printed in a limited number of copies and is intended for internal use by the Department of Indian and Northern Affairs. Copies of each issue are distributed to various public repositories in Canada for use by interested individuals.

Many of these reports will be published in Canadian Historic Sites/Lieux historiques canadiens and may be altered during the publishing process by editing or by further research.

La série intitulée Travail inédit est imprimée à tirage limité pour les besoins du ministère des Affaires indiennes et du Nord canadien. Des exemplaires de chaque rapport sont distribués à des archives publiques au Canada, où les intéressés peuvent les consulter.

Bon nombre de ces rapports paraîtront dans la revue intitulée Canadian Historic Sites/Lieux historiques canadiens, et pourront être remaniés ou mis à jour.

Fort Rodd Hill:
A Structural History of Upper Battery
and Lower Battery
by Joseph Greenough

viii	Abstract
ix	Acknowledgements
1	Introduction
8	The Evolution of the British Coast Fort
28	Rodd Hill and the Typical Coast Fort
39	Building Inventory
39	Introduction
40	Upper Battery Inventory
40	1895-98
40	1903-05
41	1906-20
41	1920-35
43	1935-56
44	Lower Battery Inventory
44	1895-98
44	Before 1903
45	1906-39
45	1939-56
46	Armament
48	Anti-Aircraft Guns
51	Conclusions
56	Structural Notes
56	Introduction
56	Emplacements: General

59	Emplacements: Rodd Hill
60	Magazines and Subterranean Structures: General
62	Magazines and Subterranean Structures: Rodd Hill
65	The Casemate Barracks
67	Other Extant Structures
69	Building Interior Notes
69	Introduction
70	Fixed Use Buildings
70	Lamp Rooms
72	Lamp Recesses
72	Shifting Lobbies
73	Cartridge Stores
74	Shell Stores
75	Ammunition Passages and the Transport of Ammunition
77	Miscellaneous Fitments (Underground Structures)
77	Artillery Stores
78	Emplacement Recesses
79	Lyddite, SAA Store
79	Electric Light Directing Station
79	Telephone Exchange
79	Oil Store (Lower Battery)
80	Crew Shelters
80	Variable Use Buildings
83	Equipment
83	Introduction
85	The Gun
94	The Carriage
109	Cartridges
113	Shells
116	The DRF
118	Stores
130	Consolidated Equipment Tables: Introduction
132	Consolidated Equipment Tables: Gun Equipment

135	Consolidated Equipment Tables: Carriage Equipment
150	Consolidated Equipment Tables: DRF Equipment
151	Consolidated Equipment Tables: Stores
163	Appendices. An Introductory Note.
166	Appendix A. Note on Lamp Recesses.
171	Appendix B. <u>List of Changes</u> Entries Detailing the Evolution of the Mark VI Gun, 1883-1904.
172	Appendix C. <u>List of Changes</u> Entries Detailing the Evolution of the Mark IV Carriage, 1889-1904.
175	Appendix D. <u>List of Changes</u> Entries Detailing the Evolution of the DRF, 1883-1904.
176	Appendix E. Contents of Chest, Tool, Filled, No. 11E.
181	Appendix F. Fuses.
188	Appendix G. Magazine Lamps.
191	Appendix H. Plugs.
193	Appendix I. The Aiming Rifle.
198	Appendix J. Tables.
200	Abbreviations Used
201	Endnotes
220	Bibliography
Tables.	
47	1 Armament and Carriages, 1900.
53	2 Upper Battery: Dating of Extant Structures and Condensed Notes on Building Compatibility.
54	3 Lower Battery Casemates: Dating of Extant Structures and Condensed Notes on Building Compatibility.
55	4 Lower Battery: Dating of Extant Structures and Condensed Notes on Building Capability.
71	5 Fixed and Variable Use Buildings.

- 165 6 Year Correspondence of List of Changes Paragraphs (to 1904).

Illustrations

- 225 1 The RML Fort (1).
 227 2 The RML Fort (2).
 229 3 The RML Fort (3).
 231 4 The RML Fort in Transition (1).
 233 5 The RML Fort in Transition (2).
 235 6 Rodd Hill: the earliest surviving plan of Lower Battery (1892).
 237 7 Rodd Hill: the casemate barracks (1897).
 239 8 Upper Battery: Record Plan 2 (1903).
 241 9 Upper Battery: Record Plan 3 (1903).
 243 10 Lower Battery: Record Plan 2 (1903).
 245 11 Lower Battery: Record Plan 3 (1903).
 247 12 Lower Battery: Record Plan 4 (1903).
 249 13 Lower Battery around 1930.
 251 14 Rodd Hill from the air, October, 1940.
 253 15 Lower Battery from the air, 1943.
 255 16 Lower Battery around 1937.
 257 17 Lower Battery from the air, 1944.
 259 18 Point Pleasant Battery, Halifax, N.S., 1903.
 261 19 A Shifting Lobby.
 263 20 8 cwt. wrought-iron davit.
 265 21 "Carriage, Garrison, Disappearing, B.L. 6-inch Mark IV."
 267 22 Carriage, Garrison, Disappearing.
 269 23 Carriage Garrison, Disappearing.
 271 24 Recoil Cylinder.
 273 25 Connections, Pressure Gauges.
 275 26 Gauges, Pressure.
 277 27 Raising Valve.

- 279 28 Raising and Recoil Valves.
281 29 14 lb. 1203 Cordite Cartridge.
283 30 12 lb. E.X.E. Cartridge.
285 31 Armour Piercing Shell.
287 32 Common Lyddite Shell.
289 33 Battery and Key, Test and Firing, Box.
291 34 A Leclanché Cell.
293 35 Box, Obturating Pads and Discs.
295 36 Tube, Extractors (P and P special).
297 37 Percussion Base Fuze.
299 38 Fuze, Time and Percussion, Middle, No. 54.
301 39 Percussion Locks.
303 40 Pump, Air, Double.
305 41 Pump, Air, Double.
307 42 One of the Rodd Hill Guns (ca. 1934).
309 43 Compressed air reservoir.
311 44 Morris Aiming Rifle.
313 45 Electric Vent-sealing tube.
315 46 Two Percussion Tubes.

Abstract

Upper Battery and Lower Battery at Fort Rodd Hill in Victoria, British Columbia, were constructed in the late 1890s as part of the defences of Esquimalt Harbour. The site of the batteries was continuously in use by the military down to 1956, although by then the batteries themselves were long obsolete and the amount of military activity was never, in peacetime, very great. This paper deals with the origins of the type of coast fort of which the two Rodd Hill Batteries are good examples, discusses the structure of the batteries, and outlines the problems encountered in assembling research material on this subject.

Acknowledgements

The author wishes to acknowledge the co-operation he received from Mr. J.E. Rippengale and Mr. Robert Clapp, without whose invaluable assistance at every stage of the preparation of this manuscript, it would probably never have been finished.

Introduction

This manuscript began as a projected structural history of Upper Battery, Rodd Hill. Early on, it became apparent that there was insufficient information to justify a history of Upper Battery alone, and the manuscript was expanded to its present form. Even then, the paucity of information on the Rodd Hill buildings has made the preparation of this manuscript a frustrating business, and the final result, in fact, raises more questions than it answers.

Lytton Strachey once observed that the history of the Victorian age could never be written because of the surfeit of information on the period. He underestimated the ability of the Victorians to destroy records. In 1880 the War Office archives contained "more than 6,000,000 registered papers, the accumulation of the (preceeding) 25 years."¹ In the same year, a committee was appointed to consider the problem of storing this enormous volume of material. It would be an over-simplification to say that the committee recommended that the bulk of the records be destroyed, but that comes close to being an accurate description of what, in fact, happened. Although the committee recommended that all "official" papers be retained, it also suggested that virtually everything else be destroyed after a specified retention period - usually five to 10 years.² In practice, this meant that only executive papers were kept. As a result of the acceptance of the committee's recommendations, there now survives a glut of material on British military policy in the later 19th century and precious little on

anything else.

The handicap imposed by the absence of any material on the construction of Rodd Hill was never entirely overcome in the course of preparing this manuscript. It was some time, indeed, before the exact nature of the problem was entirely clear. It now seems likely that the entire surviving documentation on the construction of Rodd Hill (i.e. documents concerned with the physical structure of the work instead of the policy behind the construction) consists of a handful of plans and a few stray letters and papers which have somehow escaped the fire.

These plans are the single most important source. For the features with which this paper deals (Upper Battery and Lower Battery), the total number of available plans dating from the early period is 11. Of these, one is clearly a preliminary plan drawn before work was commenced; another may have been drawn before the area shown in it was, actually, constructed; two contain so little detail as to be virtually useless; and the remaining seven are record plans. These last require some explanation. A record plan, as the name suggests, was intended as a physical record of a work or building "as built." Record plans were supposed to be drawn from measurement. They were intended as a way to allow the Deputy Director of Works (Fortifications) to check the work of the engineers in the field. Record plans, therefore, ought to be considered accurate. But, even Royal Engineers are human and errors may, conceivably have crept in. The author has in fact come across one record plan (for a work in Halifax) which could not have been drawn entirely from measurement.

Of the seven record plans of Upper and Lower Rodd Hill, three are of Upper and four are of Lower. One for each fort consists of a standard Admiralty chart of Esquimalt harbour altered to show the range and arcs of fire of the guns.

These are therefore useless for the purpose of this paper. This leaves five plans, and these are the single most important and reliable source for the structure of the works as originally constructed.

Canada has been every bit as thorough as Britain in destroying of construction and maintenance records for the fort, although to even less purpose; the destruction in Canada appears to have been largely a matter of chance. For the Canadian period a few additional plans are available, although a surprising number are merely altered copies of the record plans, as well as some fragmentary maintenance records, most of which raise more questions than they answer. Canadian records get more detailed and useful around the beginning of the Second World War, but, as neither Upper nor Lower Battery figured very prominently in that conflict, these are not of much use for present purposes either.

This paper is thus based very largely on the examination of a handful of plans, a physical examination of the site as it now exists, and a lot of (hopefully) intelligent guesswork. To supplement the rather meagre pickings from the primary sources and to increase the probability of making a correct guess, three additional sources were used: War Office publications, information on comparable batteries and the memories of a few persons who served at the fort.

Of these, the examination of comparable batteries proved the least rewarding. There is in fact only one entirely comparable work in Canada (Macaulay, also in Esquimalt) and we know as little about it as we do about Rodd Hill, so that comparative research was not much help.

In fact all coast works constructed in Canada in the same period as Rodd Hill are as badly documented, although, in some instances, the number of plans available is greater.

War Office publications were more rewarding, although the bibliographic work involved was somewhat time-consuming. From various textbooks, handbooks, treatises and manuals, the author could gather enough information to enable him to interpret the function of some of the features shown on the plans. In addition, the official publications were a fertile source of information on the equipment normally associated with a turn-of-the-century coast battery. This last was, as it happens, the most easily researched of the topics treated in this paper and the (comparative) ease with which the information was gathered and the quantity of information available has, to a certain extent, distorted the final product. It is no accident that the equipment chapter is as long as the rest of the paper.

The author only began to employ oral history techniques late in the course of his research and, it must be admitted, as a last resort. The drawbacks of oral history are obvious. For one thing, it is highly unlikely that a reliable eye-witness for the imperial period can now be found. For another, the reliability of a witness's memory is a difficult thing to check, and independent corroboration of a statement by at least two persons is desirable. Notwithstanding these and other problems, the limited amount of oral history employed in the preparation of this paper did produce surprisingly good results.

Before leaving the topic of oral history, it might be appropriate at this point to note that, since it now is obvious that many of the questions about the fort will never be answered through official documents, oral history may be the only remaining course open to researchers. Although there are problems in assessing the information gathered in interviews, there are a few factors in the case of Rodd Hill which tend to increase the probability of success with such a project. The two most important of these factors are the

relative youth of the site and its comparative stability over time. Only the first decade or so of the history of the fort is entirely beyond living memory, and there is every indication that nothing much was changed on the site between, say, 1900 and 1940. I would therefore recommend that any future historical research projected for the fort include an oral history program.

From the above, the following facts about the documentation for Fort Rodd Hill should be apparent. First, the documentation for the structures is virtually non-existent. Second, that while secondary sources go some distance toward providing the historian with the background to make an intelligent guess about some aspects of the fort (e.g. the equipment), not all questions can be answered in this fashion. Third, the period of optimum documentation is after about 1940. Fourth, the period of optimum documentation coincides with the period for which best results could be expected from any oral history program. It must be emphasized that these facts apply only to matters of building structure and building use. There is no period in the history of Rodd Hill where there is insufficient documentation to write intelligently on the political or military considerations which shaped British or Canadian defence policy and how that policy was reflected in Esquimalt in general and Rodd Hill in particular. Nonetheless, it is difficult to escape the conclusion that if literal accuracy is required for any building restoration or furnishing, it may be possible to provide the information for such work only for a comparatively late period in the history of the fort.

It should be obvious from the above that the information contained in the present paper will not, in itself, be sufficient for restoration; it is something of a misnomer to call this paper a structural history. A paper

of this type is, however, valuable for a number of reasons. For one thing, it finally gets the major historiographical difficulties involved in the restoration of Rodd Hill on record. For another, it serves to point out the areas in which further work is required and indicate those areas in which, given our present lack of information, we are never likely to know much more. Finally, the general information on British coast defence practice contained in this paper serves to place the fort in the context of coast defence in general.

It ought not to be concluded that the difficulties are entirely insurmountable. The relative newness of the fort and the comparative uneventfulness of its history tend to make the task of restoration easier than might otherwise have been the case. It appears that the central fact about the evolution of Upper and Lower battery is that they never evolved. The basic fabric of the extant structures of both batteries has changed little since the day of their construction, and most of these structures are in reasonably good condition. Some of the interior fittings are clearly original. In many instances, therefore, we are now in a position, with only a little additional work, to restore the building fabric. The following paper indicates where this is the case.

In format, the paper moves from the general to the particular. The opening chapter discusses the evolution of British coast fort design in the later 19th century. The following chapter, describes the considerations which the Royal Engineers took into account when designing a coast battery, and discusses the design of Rodd Hill. An inventory of the extant structures follows, serving both to date the remains and indicate what other buildings are known to have existed. Chapters follow on the structure of the extant buildings and their interiors, and on the equipment

associated with a coast battery equipped with the guns and carriages present at Rodd Hill.

As I mentioned in the beginning of this introduction, this paper was originally intended to be only a structural history of Upper Battery. As originally scheduled, the time allotted for the research and writing of a structural history of Upper Battery, Lower Battery and the casemate barracks was over a year and a half. With the advantage of hindsight it can be said that this was clearly too generous an estimate given the lack of material. The present structural history (of all three) was researched and written in 11 months. This has proved to be not quite generous enough. In the latter stages of research, the author was forced by time limitations to choose between working on the guns, gun equipment, and other artillery features or working on the barrack and barrack fitments. As the former are immeasurably more important in the case of Rodd Hill than the latter (at least the guns were actually mounted and most of the attendant equipment procured for them: the barracks at Rodd Hill were rarely used), the choice was easily made, but, the sections on the casemate barracks have inevitably suffered. This paper can only treat the subject of the casemate barracks in a highly superficial manner and much more work is required on this aspect of the fort.

The Evolution of the British Coast Fort

The evolution of coast fortification design is almost entirely a 19th-century phenomenon. Before about 1850, the same principles governed the design of works for both coast and land defence. A permanent fort in a coastal position was much like a permanent fort anywhere else. Temporary works were built to the same principles as field works everywhere.

The evolution of coast fortification design is also largely an Anglo-American phenomenon. While France and Prussia led the field in permanent fortification, they, like all continental powers, were more concerned with the defence of their land frontiers than with that of their coastlines (Prussia, indeed, had little to worry about). Britain only faced the problem of an exposed land frontier in some of her colonies, while the United States, after 1815, ceased altogether to worry about her land frontier defences. Both countries thus tended to concentrate their military engineering energies on coast defence. Initially engineers in both countries borrowed from European theories of permanent fortification but, as the century progressed, coastal works in Britain and the United States came to resemble each other more than any of the permanent works erected in Europe. In 1800, coastal fortification as such went unmentioned in fortification textbooks. By 1900, it was, in effect, an independent subject.

The emergence of coast fortification as a distinct and specialized subject was the direct result of developments in

industrial technology in the latter half of the 19th century. The evolution of coast fortification theory and practice was the result of parallel but mutually reinforcing developments in certain aspects of that technology - advances in metallurgy and improvements to the steam engine being two of the most important. The metallurgical advances were probably the most significant factors, since they made possible the development of both ship armour and the high-powered, breech-loading gun.

In the second half of the 19th century the pace of technological advance was very rapid. Prior to 1850, it is only a slight exaggeration to say that there had been no fundamental changes in the theory of fortress design since the invention of gunpowder. While the shape and appearance of forts changed somewhat from century to century, the changes had more to do with military fashion than any improvement in the cannon. After 1850, however, whole weapons systems could become obsolete almost overnight. In the British service, for example, four different types of gun succeeded each other within less than 30 years. This bewildering series of changes in weaponry was paralleled by equally confusing changes in fortress design.

In general, the development of British coast defence in this period can be divided into three phases. Before embarking on a description of each, it might be useful to recount the state of ships and forts, of guns and gunnery, just before the period of rapid development.

As the gun was common to both ship and fort, it is best to start with it. It was still quite a crude weapon. One writer has described the principal guns of the period (32-pounder smooth bore cannons) as follows:

They were, we must admit ... mere blocks of cast iron, the sole machining spent on them being the formation of the bore and the

drilling of the vent. The velocity of the shot was about 1600 feet per second and the energy developed by the charge was about 570 foot-tons.¹

The standard gun carriage was equally primitive. A shipboard carriage was

made entirely of wood ... It was carried on wooden trucks, or sometimes the rear truck was replaced by a chock. The recoil was controlled by the friction of abnormally large wooden axles, by wedges acting on the trucks, and finally was brought up by the breeching by which the gun was attached to the vessel's side.²

In a fort, slightly more sophisticated carriages were available, but the basic means of controlling recoil were still friction and physical restraint.

The forts in which the guns were mounted, while not exactly "primitive" in quite the same way as the guns, were also products of the thinking of another era. The old bastion system still dominated fortification, either in one of its late 17th-century incarnations (the Vauban systems, for example) or in one of its later variations (polygonal fortification). In any form, the system was in theory rigidly symmetrical, relying on an established vocabulary of geometric forms. Although in practice the permanent forts of the era tended to be both less complicated and less tidy than the textbook plates, the fundamental form remained. The area to be fortified was enclosed with ramparts, frequently supported by masonry walls, and armed with a large number of guns. There were two basic methods of mounting the guns: either on the ramparts or in subterranean chambers (known as casemates). Both methods could be employed in a single work.

Like the guns and the forts, the principal warships of the early 1850s were not visibly different from those of a century earlier. But here appearances were somewhat deceptive. Most navies had finally admitted that steam power had arrived for good. The introduction of steam did not, however, bring about any immediate changes in warship design and the sight of a multi-decked ship of the line under partial sail and belching black smoke remained a common sight until much later in the century.

The introduction of the steam warship did nonetheless, have strategic implications - especially for Britain. It was obvious that steam power made the channel less of an obstacle than it had hitherto been. Beginning in the 1840s, there were occasional public controversies about the adequacy of existing British defence arrangements. The most famous such dispute occurred in 1848 when someone arranged for the publication of a letter from the Duke of Wellington (then Commander in Chief of the army) to the Inspector General of Fortifications (Sir John Fox Burgoyne) in which the old duke was openly critical of government policy. But these early controversies were not sufficient to provoke a government to action.

Public discussion of the state of the defences did, however, give the Royal Engineers the incentive to examine the question. Several junior officers published papers on the subject in the 1840s and 1850s³ and twice during this period the Inspector General of Fortifications himself contributed to the growing volume of coast defence literature.⁴ Burgoyne was a conservative engineer. More often than not he stubbornly resisted new ideas. He believed, for example, that rifled artillery was a development of little consequence.⁵ On the subject of coast defence, he was equally wrong-headed. He did, nevertheless, elucidate one important point about the design of coastal

fortification:

On the whole it may be understood that a line along the shore may be perfectly fortified against any assault from afloat by very moderate means, and by works of far less costly and elaborate character than those applied to land defences.⁶

Starting with this premise, it is a comparatively short jump to the realization that coast fortification and land fortification are entirely separate entities. Burgoyne, as it happens, did not follow his reasoning through to its logical conclusion. Later engineers did.

Discussion of the future of the coast defences of Britain remained largely academic until 1858. In that year, the French launched La Gloire - the world's first iron-clad warship. The repercussions of this were enormous since the iron hull rendered obsolete the smoothbore cannon and, by implication, all existing ships and sea forts as well.

Britain, as the leading naval power, was most affected by this revolution. The British response took two forms. Two ironclads, Black Prince and Warrior, were laid down. And on 20 August 1859 a Royal Commission was appointed to "consider the defences of the United Kingdom."⁷

The commission's report, published on 7 February 1860, recommended the construction of a chain of forts to protect naval arsenals and dockyards, the total cost of the recommendations being reckoned at £11,850,000. After some hesitation and many changes in the details of the recommendations, the report was accepted by Parliament. Work began on the forts in the early 1860s. It was to continue for almost half a century.⁸

The history of modern English coast defence starts with the royal commission. In fact, the whole story of the design and evolution of British coast forts could be told

in terms of works designed to implement the recommendations of the commission and of the subsequent alterations to these works, either during construction or after completion. The story is one of continual alterations in design to accommodate changes in artillery or to incorporate improvements suggested either by experience or by experiment. Although the process was continuous, it is possible to distinguish phases in the process. But one must always remember that any such division is arbitrary and that almost any British coast fort built between 1860 and 1900 was likely to display traces of several different stages of fortification development.

The determining factor in this evolutionary process was the development of artillery between (roughly) 1850 and 1900. And the most important factor in the development of artillery, at least as far as coast artillery was concerned, was the evolution of the armoured ship. In fact, La Gloire and Black Prince arrived at an extremely awkward time in the history of artillery. The smoothbore cannon was already on its way to obsolescence before the armoured warship arrived on the scene. The ironclad was the last nail in the coffin, since both the navy and the coast artillery were concerned, as even the largest smoothbore was insufficiently powerful to penetrate armour. The problem was that nothing immediately available existed to replace the smoothbores.

The list of innovations proposed for artillery in the middle of the 19th century is a comparatively long one and includes the use of rifling, breech-loading and cast iron (as opposed to wrought iron) in gun construction, as well as shell project
iles and the scientific calculation of the stress points in a gun barrel to allow a more efficient distribution of metal. In England, William Armstrong's experimental gun, first shown to the War Office in 1855, incorporated all of the innovations listed above. After a

long series of trials, the British army adopted it and took it into service in the early 1860s.⁹

The problem with the Armstrong gun was that it promised more than it delivered. Although undoubtedly more efficient than its predecessors, it was also less reliable. From the point of view of fixed (i.e. fortress) gunnery, there was an especially troubling drawback: the breech mechanism was insufficiently strong to withstand the firing of heavy shells. Large-calibre Armstrongs were, therefore, out of the question.¹⁰ As the lighter guns were ineffective against ship armour, this put the military authorities in the early 1860s in something of a quandry. With what were they going to arm all those forts recommended by the Royal Commission?

The answer to the question proved to be a new type of gun, the rifled muzzle-loader (RML). This was an attempt to combine the best qualities of both the Armstrong gun and the muzzle-loading smoothbore, the reliability of the latter with the superior range and accuracy offered by the rifled barrel and shell ammunition of the former. The RML was essentially a stop-gap measure designed to tide the artillery over until someone invented an adequate breech mechanism for large guns. As it happened, the search for the latter took 15 years, during which time the RMLs were the principal armament of all British coastal fortifications.

The provision of a gun adequate to the task of destroying armoured ships was not the only problem which confronted the military. The Royal Engineers had never been innovators in the field of fortress design. English fortification had always been characterized by a rather uneasy hodge-podge of styles: bits and pieces of the latest continental vogue mixed in with whatever happened to be expedient and cheap. The challenge of designing all the

works recommended by the Royal Commission did something to clarify engineer thinking, but the results were sometimes a trifle odd.

One can discern three major influences in the design of the early RML forts. The first of these was the long-standing British practice of mounting ordnance in extremely simple barbette batteries, which were little better than field works provided with the absolute minimum of masonry. The second was the simplified polygonal trace defended by casemated barracks and caponiers which was then popular in Europe. The third was the American practice of mounting coast armament in casemate tiers to achieve a maximum concentration of gunfire. The juxtaposition of these three elements was only achieved with some difficulty since these three elements do not in fact mix very well. Casemates and the polygonal trace belong together, but the polygonal trace, which was fairly rigid and geometrical, contrasted oddly with the barbette batteries, which were relatively informal affairs, basically concerned only with the protection of the gunners from enemy fire and in general undefended in the rear. Quite early on, the engineers divided the forts required by the commission report into two classes - those required for land defence and those strictly for coastal defence - and the major influence of the polygonal trace was felt in the former (where, in fact, its use was most appropriate). Some of the more important of the early coast forts, however, were also basically polygonal, and the occasional casemated caponier and casemated barrack for landward defence continued to turn up in coast batteries right down into the 1880s.

In the long run, however, the barbette type battery was more important in the development of the British coast defence fort than the polygonal type. Not only was it less expensive to build, but it was more flexible in use and it

allowed better utilization of the natural terrain. As it was less geometrically rigid, it allowed the engineer designing the work greater freedom in arranging the magazines and stores necessary for working the guns. In this type of battery, therefore, lay the germ of the later coast forts in which flexibility of design, adaptability to terrain and the provision of self-contained gun emplacements were the three most important needs.

All RML forts had some things in common. To begin with, all were highly visible - an unmistakable, clearly-defined target to shoot at. The guns were always massed as in a smoothbore fort: a RML fort for two or three guns was unthinkable. A central magazine was provided, although provision was usually made at the gun for immediate ammunition needs. The guns were always kept as separated as the nature of the work allowed. In casemated works, there was only one gun per casemate. On ramparts, massive earth traverses were put between each gun. Expense magazines, cartridge stores and shelters were frequently buried in the rear of the traverses. Finally, some form of protection from enemy fire was provided for the gunner. In some instances, the early ramparts and traverses were held to be sufficient. More commonly, some kind of iron shield was installed. Casemate embrasures usually had iron shutters, and shields were even incorporated into earth embrasures.

If one were to characterize RML forts in a single phrase, one could call them transitional works. They provide the link between the regular fortification systems of the smoothbore era and the first generation of true coast defence forts. The armament was also transitional. And so, not surprisingly, was the carriage on which most of the guns were initially mounted.

The early RML guns were mounted on carriages which were

identical to those in use in the smoothbore era. The gun was mounted on a carriage which was in turn mounted on a platform which was inclined slightly. When the gun was fired, the gun and the upper carriage slid up the platform until the weight of the gun and carriage, friction and gravity combined to stop its motion. As the RML guns got bigger and heavier, hydraulic buffers were added to assist in arresting the motion of the gun, but the basic configuration of the carriage remained the same. In all cases, it should be noted, a combination of gravity and muscle-power got the gun back into firing position.¹¹

This arrangement left a good deal to be desired. It was clumsy. Inside a casemate it was downright awkward; in an open battery it left the gun and crew exposed to enemy fire. The iron shields of the early RML forts were one attempt to minimize some of the disadvantages of the carriages, but it was apparent from quite early in the history of the RML gun that a more lasting solution to the difficulties was the development of a better carriage.

In 1865, a Scots militia captain suggested what proved to be the ideal solution to the problem. Captain Moncrieff's invention, initially called the "protected barbette traversing carriage," was the first practical disappearing gun. The gun was mounted on a sort of sophisticated teeter-totter, on the other end of which was a counterweight. For firing, the gun was allowed to rise above a parapet. When fired, its own recoil brought it down under cover. Moncrieff had thus managed to solve both the recoil and the loading problems. The most important fact about the Moncrieff carriage, however, is that the principle involved is best suited to RML guns which require different position for loading and firing.¹²

The introduction of the Moncrieff carriage also effected a transformation in the design of the gun

emplacement - a fact was to have consequences far beyond the RML era. The characteristic Moncrieff emplacement was a circular pit, open at the back and protected in front by a concrete apron. All subsequent medium and heavy coast gun emplacements were descended from the Moncrieff gun pit.

In most instances, the new Moncrieff emplacements were worked into existing forts, leading to a situation in which one fortification system and the embryo of its successor co-existed uneasily.¹³ The nearly invisible pits contrasted oddly with the highly visible ramparts and embrasures of the older works. By about 1880, the engineers had begun to realize that the Moncrieff emplacements and their successors could be more profitably employed in a different type of fort; one which took advantage of the near-invisibility of the pits and the tactical advantages to be gained by discarding some of the rigid rules employed in the design of earlier permanent fortification.

By that time, the era of the RML was ending. At best, the RMLs had been a stop-gap weapon. As the size of the guns increased and the art of gunnery became more sophisticated, the disadvantages of using an RML gun multiplied. The problem of loading was perhaps the most important of these disadvantages. At any size above 7 inches, the shell was too heavy to be manhandled. Even with the Moncrieff carriage, loading presented difficulties, and the largest RMLs would not fit on a Moncrieff. The largest of all, the monster 17.72-inch guns designed for use in Malta and Gibraltar, took a 450-pound charge and a 2,000-pound shell, both of which had to be rammed into the business end of the gun without exposing gun, gunners or loading equipment to enemy fire.¹⁴ While this presented the engineers with a fascinating design problem, it was obvious that the only satisfactory long-term solution was the provision of a workable heavy breech-loader and by 1880 this

was within sight.

The development of a practical breech-loader required yet another major change in the design of gun carriages, since neither of the standard types of RML carriage was suitable for a breech-loading (hereafter BL) gun. Different rules applied in each case. The hydraulically-controlled slide up an inclined plane was not particularly appropriate for BL guns since the breech tended to end up in an awkward position for loading. The Moncrieff carriage, while adaptable for the purpose, was also inappropriate since there was no logical reason why a breech-loader should have different positions for loading and firing.

This last point was not immediately appreciated, and among the first carriages proposed for the new BL guns were several variations on the disappearing principle. At least four different designs were produced in the early 1880s and all made use of hydraulics instead of counterweights.¹⁵ Initially, all were called Moncrieff hydro-pneumatic carriages, despite the fact that Moncrieff had had nothing to do with the design of any of them. Later, Moncrieff's name was relegated to the old counterweight carriages and the new designs became known as hydro-pneumatics. Ultimately they were simply called HPs.

One of the four different types of HP designed in the early 1880s was the work of Sir W.G. Armstrong, Mitchell and Company. This was the carriage accepted for development.

Known commonly as the Elswick (or Armstrong) HP carriage, it was initially developed for the 6-inch BL gun. In this carriage, a hydraulic system absorbed the energy from the recoil of the gun and stored it for subsequent use in elevating the gun to the firing position. It was a fairly complicated piece of machinery and it proved to be not particularly reliable, but it did allow a 360-degree arc of fire and provide maximum protection for both gun and crew.

In the hands of an experienced crew, it could be fired at the rate of about one round every two minutes, a rate which was considered adequate by the standards of the 1880s.

Despite the fact that the HP carriage was not particularly well suited to BL guns, it was accepted for use with both medium and heavy cannon. There were three reasons for this. In the first place, the disappearing principle had proved successful with RMLs and it was only natural to stick with a successful of design. In the second place, the HPs were ready before any of their competitors had been perfected. Finally, the War Office conducted a trial on the effectiveness of the carriage and was well pleased with the results. The trial in question is best described by Ian Hogg:

A pit was constructed on the tip of Portland Bill and a dummy 6 in. gun was assembled to a disappearing carriage therein. Mechanism was provided to raise the gun every two minutes to firing position, remain in the 'up' position for 20 seconds, discharge a smoke puff, and then retire into the pit once more. HMS Hercules was then given carte blanche to bombard it and do whatever damage it could. The trial began with Gardner and Nordenfeldt machine guns firing hundreds of rounds without a single bullet striking the gun or falling into the pit. Then the ship's 10 in. RML guns began firing broadsides; the gun remained undamaged in spite of some apparently close shots. Then the ship's guns were allowed to fire independently under their own gun captains; this was even less effective. During all the heavy gun firing, the ship's 6-pounder QF [quickfiring] guns were allowed to shoot

whenever they saw the gun raised, but not one hit was made on the gun, its carriage, or the emplacement.¹⁶

The results of the trial were not, in fact, as straightforward as they at first appear. In the first place, one could question the very basis of a trial which tested the defensive rather than the offensive capabilities of the gun. Realistically and practically, it would seem that the military ought to have tested the ability of the gun to hit the ship rather than vice versa. Secondly, one wonders which was more significant: the fact that the navy failed to hit the gun or the fact that the navy failed to hit even the emplacement. This in fact seems more remarkable and should have raised doubts as to the necessity of such elaborate protection for gun and gunner was really necessary. As it happens, the War Office chose to ignore this aspect of the trial, and the brief vogue of the HP carriage began.

It should be kept firmly in mind, that the HP was not the only BL carriage in service, even during its period of maximum popularity. The 1888 edition of the Treatise on Military Carriages lists, in addition to numerous HP mountings for 6-inch, 9.2-inch and 10-inch guns, barbette mountings for 10-inch, 9.2-inch and 8-inch guns and Vavasseur mountings for 8-inch.¹⁷ Both the barbette and Vavasseur mountings were variations on the old inclined plane and hydraulic buffer RML carriages and were thus even less suitable for BL guns than the HP. Nonetheless, the military did have a choice of mountings for the new BL guns.

As the guns changed, so to did the batteries, although the conversion to BL artillery was only one of the factors involved in the changes in coast fort design which occurred in the late 1880s. The main factor was the evolution of the

warship. It might, at this point, be useful to briefly trace the development of the warship from the Warrior to the turn of the century.

At sea, one of the earliest casualties of the ironclad era was the shipboard broadside. Only the very earliest ironclads had their armament arranged in the traditional manner. Thereafter chaos reigned in the arrangement of naval armament for the better part of half a century. Designers were caught in an armour-artillery spiral: the heavier the armour, the heavier the guns necessary to penetrate it; the heavier the guns (which meant that fewer guns could be carried), the heavier the armour necessary for protection, and so on. As in the coast forts, the absence of a large-calibre BL gun made the matter even more difficult. In fact, it was the requirements of the navy which speeded development of the BL gun. Eventually, around 1890, warship design began to stabilize. The principal ship of the time - what we now call the pre-dreadnought battleship - came to be armed with small numbers of large-calibre guns mounted in turrets and protected with a thick but comparatively narrow belt of armour which covered all vital areas of the ship. Smaller units (cruisers) repeated this arrangement on a lesser scale.¹⁸

The long period of near-chaos in warship design had also produced several entirely new classes of vessel. In the early 1870s, several nations started experimenting with the locomotive torpedo in an attempt to penetrate ship armour. In the following decade most navies began construction of small, fast warships to deliver them. Finally two different types of ship were produced: the torpedo boat and its adversary, the torpedo boat destroyer. (Around World War I, the distinction disappeared, and both acquired the generic name 'destroyer'.) Not only did the

introduction of torpedo craft have a profound effect on heavy warship design - the whole system of armour and bulkheads had to be altered - it also had an inevitable effect on coast fortifications.

Between 1880 and 1890, the cumulative effects of the changes in warship artillery and armour, the introduction of BL artillery and the development of carriages for it, and the continuing evolution of a British coast fortification style all combined to produce what might be called, for want of a better term, the mature British coast defence fort.

The single most important factor was the evolution of the warship. In response to the challenge of the pre-dreadnought warship and the armoured cruiser, the engineers utilized the same principles as the ship designers: the deployment of a comparatively small number of guns, arranged to provide the minimum possible target and possessing the widest possible flexibility of traverse.

This had two immediate results: it spelt the end of the casemate in coast works and it brought the self-contained semi-circular gun emplacement (and the descendant of the Moncrieff gun pit) into its own. The casemate thus disappeared at the very moment when a gun had finally been invented which could have been practically worked in one (and, incidentally, around the same time that the armoured casemate was introduced into warship design). With the casemate went the last vestige of the polygonal system in the coast fort. The new works, arranged around the self-contained gun emplacements, were rather like the old barbette batteries, although they were even less rigid in layout. Most provision for defence against land attack also disappeared at this time, although the last vestiges were not discarded until the coast work reached its ultimate form in the following decade.

Many of the early forts designed to these principles,

were armed with guns mounted on HP carriages. The design of carriages for BL heavy guns in fact lagged behind for almost a decade. One reason was that in the late 1880s, the main priority in artillery design was the development of a gun and carriage to meet the menace of the torpedo boat. In the early 1880s, no existing gun was adequate for the destruction of a fast-moving target. The problem was in finding a gun carriage which would allow a gun to be loaded and fired quickly. This in turn reduced itself, as almost all artillery problems do, to the question of the control of recoil.

In the course of the 1880s, two different mountings were developed in Britain: the elastic cone mounting and the non-recoil mounting. The latter was more successful and was adopted for use. With this mounting:

A pedestal is bolted to a ring fixed in concrete...the lower part of the carriage is pivoted to the pedestal, and has trunnion holes for the trunnions of the upper part, generally termed the cradle. The cradle can be elevated and depressed by hand or by gearing; the gun rests in the cradle and can move in the direction of its axis....

The hydraulic buffers connect the gun to the cradle and absorb the recoil; springs which are compressed during recoil, force the gun back to its original position.

It will be seen that in this mounting the gun always recoils in its line of axis, whereas (earlier)...guns and carriages always recoiled horizontally, more or less.¹⁹

The advantages of this mounting are obvious. Only the gun is allowed to recoil and it always returns to its original position. The carriage never moves and the

sighting and traversing mechanisms are independent from the gun, allowing continual adjustment, even while the gun is recoiling.

To speed things up still further, fixed ammunition - i.e., ammunition in which cartridge and shell are joined as in a rifle bullet - was introduced. The brass cartridge case doubled as a breech seal, eliminating the need for a complicated breech mechanism, all that was required was something to keep the case from popping out when the shell was fired.

The whole package was known as the quick fire (hereafter QF) gun. Early QFs were light - 3 and 6 pounders. Their introduction caused no revolution in coastal fortification since most QF batteries were simply scaled down versions of medium and heavy battery designs. The introduction of these weapons did set artillery designers thinking: was the same type of carriage adaptable for larger guns? The answer was only a qualified "yes," since proper QF carriages were only practical for guns up to 60inch. The principle of axial recoil was, however, universally applicable to BL carriages, and, as the barbette carriages utilizing the principle were immeasurably better than any of their competitors, they quickly swept the field.

The evolution of the QF and barbette carriages was accomplished rapidly. The 1888 edition of the Treatise on Military Carriages listed no QF mountings at all and only the old Vavasseur and inclined-plane-and-hydraulic-buffer barbette carriages.²⁰ By the 1902 edition, an entire chapter was devoted to QF carriages, and the first of the new BL barbette carriages were beginning to appear. Thereafter all BL guns were mounted on some form of barbette carriage.²¹

The HP carriage was simply unable to compete. It was

too cumbersome, too slow, too prone to mechanical failure and too expensive. Guns mounted on an HP carriage were unable to realize their full potential in long-range firing since it was impossible to elevate them more than 20 degrees. By the turn of the century, the British had ceased using HP carriages in new works. By 1914, most works which had been armed originally with guns mounted on the HPs, had been converted to guns mounted on more modern carriages.

It was in this period too that the British coast fort reached the zenith of its physical evolution. The last stages of this evolution involved the elimination of all the remaining provisions for landward defence (defence walls, loopholed buildings, caponieres, etc.), and the provision of an emplacement suitable for a barbette carriage, which, in practice, was simply a shallower version of the HP pit. After about 1905, there were no further major developments in the British coast fort. A work designed for, say, three 9.2-inch guns in 1905 and a similar work designed 40 years later would have been virtually identical. True, the carriage in the later fort would have been more sophisticated than the one in the earlier work, but the basic layout of both works would have been much the same.

There were two main reasons why the design of coast works remained static. After 1900, the changes in coast artillery centred almost entirely around the development of systems of gun directing, which in time became extremely sophisticated. Since range and position finding systems required comparatively little in the way of buildings, and since many of those buildings which were required did not have to be located near the guns being directed, these later developments in coast artillery did not bring about any fundamental changes in battery design.

The second reason was simply this: British interest in coast fortification declined after the turn of the century.

The 1859 Royal Commission had initiated a construction boom which had lasted for 40 years. By about 1900, there was not a single major harbour in the British Isles and the empire at large that did not have some kind of fortification provided for it. The momentum of construction finally started to decline. After the First World War (in which coast works did not play a major role), interest declined still further, and, except in a few cases (e.g. Singapore), construction ceased altogether.

The evolution of the British coast fort, then, occurred almost entirely in the period 1860-1900; was occasioned by the implementation of the 1859 Royal Commission; was shaped by the evolution of the warship and the development of heavy rifled artillery; and culminated in a basic fortification system which remained in use for another 50 years.

Rodd Hill and the Typical Coast Fort

As we have seen in the previous chapter, the development of the coast fort in Britain was a continuous evolutionary process. It is only with some trepidation that one can speak of a "typical" work in any given time during this development. Nonetheless it is possible to try and place individual works within the context of overall development and to speak, in general terms, about the intentions of the men who designed and built them.

Fort Rodd Hill and Macaulay Battery were both designed towards the end of the evolution of what I have called the mature British Coast fort. They belong therefore to the period in which the simplified battery, built around a relatively small number of guns sited for maximum flexibility, was beginning to become the norm in British coast forts. But it was also a period in which some of the old defensive techniques of the earlier era had yet to be discarded. Both these trends are visible in the design of Rodd Hill. Before coming to specifics, however, it might be a good idea to explore briefly the preoccupations of the engineers of the time regarding fortress design.

There are two major factors to take into account when one about the Royal Engineers. The first applies to the engineers at all times; the second is most relevant for the second half of the 19th century. The first is the simple fact that the first preoccupation of any British engineer when it came time to design a work was financial. All engineers knew that the British government was particularly

parsimonious when it came to granting money for military expenditure, and designed their works accordingly. When, in 1890, a RE officer paused to consider the factors which underlay the new designs of works then being built, he wrote as follows:

The leading influences forming the designs of the batteries now being constructed are, first, the great cost of the new guns, which renders it necessary to get as much work as possible out of each weapon, and secondly the great power of the projectiles against vertical surfaces. This renders protection by iron extremely costly, and has led to the effort to obtain the necessary security by other means. These means have been found in the separation of the guns by long intervals; in constructing batteries with gentle slopes so as to deflect projectiles striking them; in concealing the guns and batteries from view as far as possible; and sometimes in using disappearing mountings.¹

In other words, worry about the cash first, then about military matters. One wonders whether the works which were designed in the 1890s were only incidentally good coast forts and whether it was sheer luck that the form imposed on the engineers by the desire to save money also happened to be suitable for the military needs.

The second factor arose from both the nature of the 1890s fort and the siting of the average battery. All British works were erected for the defence of dockyards, arsenals or coaling stations. In other words, in almost all cases, coast works were built for the defence of locations which would, even without the existence of these works, have had a garrison of some sort and which, in all cases, were

urban. The matter of troop accommodation within the forts was thus a matter of only minor consideration. As long as coast works had been constructed with a view to defence against land attack, troop accommodation had been provided as a matter of course. But it ought to be noted that this was at least partly because the characteristic gun emplacement of a fort designed for landward defence - the casemate - was also suitable for accommodation purposes and that, in most instances, the accommodation thus provided was only intended for wartime use. One might also add that, because of their large number of guns, the forts of this earlier era required large garrisons.

The engineers therefore tended to place works and accommodation into two rigidly separated compartments labelled "fortifications" and "barracks" and design works accordingly. The motive was again at least partly financial. A free-standing, non-self-defensible brick or wood building was cheaper, easier to maintain, and caused fewer problems than a barrack casemate. Also, from the point of view of the soldiers who garrisoned the defended ports and coaling stations, the separation of fortification and barracks was desirable. Grouping the garrison in a centralized barrack complex (like Work Point in Esquimalt or Wellington Barracks in Halifax) was simply more efficient than scattering it all over the countryside. Soldiers detested the idea of living in casemates which tended to be dark, damp, and cold.

By 1890 the distinction between barracks and fortifications was, if anything, becoming even more rigid than it had been in the earlier period. The casemate was disappearing from permanent fortification, and with it went the logical accommodation for troops in the forts. Major Lewis, the engineer quoted above, mentions the subject only briefly in his survey of fortification, and then only in

terms of casemates which could double as bombproof cover or landward defence of a fort.² As few casemates were being built, his suggestions were not entirely practical. Eventually the provision of troop accommodation became a matter for ad hoc solutions - temporary buildings, tents or whatever.

The Royal Engineers, therefore, approached the design of permanent coast works unencumbered by the need to provide much in the way of accommodation for the troops who would man the works, but limited by the need to get the maximum use from the guns while spending the least money. To a fairly considerable extent, a standard system had been imposed on them as well. Unlike earlier systems of permanent fortification, the standards imposed on the engineers by British coast defence practice were not those of shape and size - there were no hard and fast rules about the placing of guns, for example - but those of thickness of wall, of material use, and of the other minutiae of the engineering profession. It is difficult to speak of this subject with real assurance, since most of the official pattern books and drawings which regulated the professional career of the late 19th century RE officer have long since been thrown out. Sufficient to say that there were certain minimum standards which the engineer officer exceeded or ignored at his peril, and that there was a professional executive - the Fortifications Office in London - to monitor his work.

One can speak in a general sort of way about these standards. The basic material employed was concrete and in most situations this alone sufficed. There were, however, places where, for reasons of damp-proofing or general habitability, other materials were employed. Of these other materials, brick was the most common, but in instances where a rudimentary covering of a concrete shell was deemed

necessary, wood was employed. Quarried stone was rarely employed (despite the fact that it had been frequently used in the RML era, because it was expensive and because most types of stone, when exposed to gunfire, had a tendency to splinter dangerously.

The modern practice of reinforcing concrete was still in its infancy. Works framed in steel were non-existent (at least in British fortifications). It was not unusual to employ steel beams to reinforce the roofs of buildings.

These were permitted to lie on the un-reinforced concrete of the side walls.

An engineer knew that the cheapest (and also one of the best) shell-resistant substances was soil, and long sloping earth embankments were frequently employed in front of emplacements. Such a slope was called a glacis, after the similar earth slope leading up to the edge of the older type of fortification, but, unlike the earlier glacis, that in the coast fort was intended primarily to absorb the impact of enemy shellfire. The concrete apron which surrounded the typical gun emplacement of the period served a similar purpose.

It was recognized that, notwithstanding the virtues of concrete and earth, the best protection for a gun emplacement was to make sure that it presented a minimal target to an enemy gunner. Concealment was thus high on the priorities of an engineer designing a coast battery. Again, the reason was economy; the less chance there was of an enemy hitting the work, the less money had to be spent on making it defensible. This consideration in turn affected the shape of the work:

Anything that makes it more difficult to aim at a battery will reduce the number of projectiles striking it, and thus increase its endurance.

For this purpose, care should be taken it have

no clearly marked objects to lay on. Making the slopes as gentle as possible, which is done for the sake of strength, is usually a help in this direction, but these long sloping surfaces are invisible in some places and very visible in others according to the surroundings. They must, when requisite, be disguised by irregularities of colour and form. The colour and surface of the battery should harmonize with the surrounding country, and there should be no well-defined sky-line.³

The considerations of disguise alone were therefore sufficient to end the reign of embrasured ramparts and acute salient angles.

The late 19th century RE officer thus had his work cut out for him when it came time to design a coast work. From the brief discussion above, it is obvious that the number of factors he was expected to take into account was well-nigh paralyzing. Major Lewis himself made one surprising admission in his discussion of the art of concealing coast batteries. This, he noted, was not something which could be settled in "the drawing office."⁴In other words, there were some things which the engineer in the field could best decide for himself, but these were few and far between and a matter of some astonishment. Elsewhere Major Lewis admitted that the concealment of batteries, that part of the design which was most individual, was rather like "scene-painting on a large scale." One gets the feeling that Lewis, although admitting the necessity of this bit of individuality, firmly believed that the scene-painter belonged in the theatre.⁵

Although the details of the planning of Rodd Hill are, to a certain extent, undiscoverable, it would appear that in outline the planning followed the standard practice of the

time. Not only was the fort like many others designed in the same period, but the course of its inception displays the same balance between local and central (London) influence suggested by Lewis's textbook.

The first detailed examination of Rodd Hill as a potential site for a battery came in 1879 when Lt. Col. T.B. Strange (the Canadian Inspector of Artillery) and Col. J.W. Lovell (The British CRE at Halifax) both submitted plans for the erection of defences on Vancouver Island. Both recommended the construction of works on Rodd Hill. Strange, who was much taken with the site, recommended the construction of a battery for two 9-inch, 12-ton rifled muzzle loading guns (RMLs). But he also recognized the limitations of the hill as a battery site:

It would, however, be advisable to build a blockhouse on Belmont Hill, otherwise a few riflemen would render the Rodd Hill Battery untenable. Belmont Hill takes it [i.e. Rodd Hill] in reverse at about 400 yards.⁶

Col. Lovell's plans for Victoria-Esquimalt were more elaborate, less practical, and (it must be admitted) better thought-out than Strange's. He examined the ground at Rodd Hill very carefully and produced a contour plan. He also noted that any battery on the site would be commanded by the higher ground behind. He recognized, nonetheless, that the site was useful for several purposes, including the command of both Royal Roads and the harbour mouth.⁷

The work he designed for the site is the first plan for Rodd Hill to come down to us. On the site presently occupied by Lower Battery, Lovell proposed a work consisting of three faces with emplacements for six 7-inch RMLs. Of the six, two were to be mounted en barbette on parapet platforms on the left face of the work. These were intended to cover Royal Roads. The remaining four, two mounted on

each of the remaining faces, fired through embrasures. Three cartridge stores and one shell store were provided underneath the traverses. No troop accommodation of any sort was shown on the plan. The total cost of the work was estimated at £7,800.⁸

The following year, Col. Nugent (the Deputy Director of Works, Fortifications, in the office of the Inspector General of Fortifications in London) produced yet another Esquimalt defence plan. Nugent had never himself seen the place, but using Strange's and Lovell's reports and plans and whatever else he could lay his hands on, he felt himself impelled to have a go at the problem. Like both Strange and Lovell, he was in favour of a battery on Rodd Point. His scheme was more elaborate than those of his predecessors. His proposed work was a casemated fort, well defended against land attack and armed with, among other things, two 10-inch RMLs. He estimated the total cost at about £21,000.⁹

Lovell, Strange and Nugent had within the space of a year produced widely differing plans for the defence of Esquimalt. It is significant that Rodd Hill was the only site that all three of them agreed on, and that all three recognized its deficiencies. It is also interesting that each of the three designs employed most of the common features of the British coast fort of the period. It was at this time that Rodd Hill was firmly established in the British military consciousness and the way was prepared for the ultimate development of the site.

None of the defence plans for Esquimalt produced in 1879-80 was ever acted on. There were several reasons for this, not the least being the fact that the Royal Commissioners appointed to investigate the defensive needs of British commerce and colonies abroad, declared in their final report (1882) that they "attached little importance to

Esquimalt."¹⁰ Since the Canadian government took little interest in the whole question, imperial pronouncements of this sort were the predominating factors in the fortunes of the Esquimalt fortress plan over the next decade. Nugent's contribution to the debate was also symbolic. Isolated in the upper reaches of the Fortification Office in London, he nonetheless felt free to promote his own project for a place he had never seen.

In 1885 the question of the defence of Esquimalt was submitted to the (British) Colonial Defence Committee. In the same year, the committee produced proposals for both the fortification of the port and the manning of the works. At this point, Rodd Hill was not included in the planning. Then in the winter of 1886-87, Col. O'Brien, the CRE at Halifax, visited Esquimalt and made surveys of the possible battery sites, including Rodd Hill, Macaulay Point, Sangster's Plain and Signal Hill. In the light of O'Brien's work, as well as of reports by several other officers, the Colonial Defence Committee solidified its thinking on the question of the location of batteries, and in June 1887 it pronounced itself in favour of the erection of batteries for 6-inch breech-loading (BL) guns at both Rodd Hill and Macaulay. In 1888, this was approved by the Secretary of State for War.¹¹

It would seem that the committee was initially responsible for the suggestion of the approximate calibre of the gun and Lt. Col. O'Brien for the dispositions and numbers. O'Brien's surviving plans suggest that he did no more than place the guns. At Rodd Hill, he put all three on the site presently occupied by Lower Battery. The first actual designs for a battery at this location appear to have originated in England. The decision to place one of the guns to the present site of Upper Battery was certainly made in Britain in 1888-89.¹²

It is not clear to what extent the design formulated in England was imposed on Major Muirhead, RE, the officer who supervised the actual construction of the forts. It is clear, however, that the actual locations were chosen long before he actually arrived in Esquimalt (in August 1893)¹³ and it seems possible that he was a mere executer of someone else's plan and not the actual designer of the work. The fact that the earliest plan of Lower Battery is dated August 1893 (and not, incidentally, signed by Muirhead) tends to support this theory.¹⁴ In any event, it is reasonably certain that the design for Lower Battery was more or less finished by the Fall 1893, and it is likely that the designs of Macaulay and Upper Battery reached their final form around the same time.

These three works display two different aspects of the coast defence fort as it had evolved by the early 1890s. Macaulay is sufficiently different from Upper and Lower Rodd Hill that it is tempting, on this basis alone, to speculate that a different engineer was responsible for each. Certainly Macaulay is the more advanced design of the two and is probably the most interesting coast defence fort design in the country. The Rodd Hill batteries are much more traditional one is tempted to say stodgy. Nonetheless, the differences are relatively minor compared to the essential similarity between the Rodd Hill batteries and Macaulay. Both were clearly designed at the same time, the one anticipating future developments, the other containing a few carry-overs from the past.

In both Rodd Hill and Macaulay, one can see the simplified design, the characteristic round emplacement and the attempt to blend the fort into its natural setting which characterized the later British coast forts. Both also have features which were abandoned within a few years after their design - notably the provision for defence against land

attack - but in both cases this left-over from the past is vestigial. The difference between the two is in the ease with which the vestigial land-defence is integrated into the overall design at Macaulay and the way in which form follows function. At Rodd Hill, all of the same features are provided, but the overall effect is clumsy, and it is difficult to see why some of the features - notably the loopholed walls - were provided at all. Macaulay perfectly fits its location. Rodd Hill looks as if it had been designed by someone who had never seen the site. And this may indeed have been the case.

Building Inventory

Introduction

The earliest surviving plan of any part of the two batteries is one showing the emplacements and adjacent features of Lower Battery, dated August, 1892.¹ One can neither make a categorical statement about the origin of this particular plan, nor can one state with any certainty that it was the first design for the battery. Other evidence suggests that the initial design work for the batteries was done in England in 1888-89.² It appears that Upper Battery was also projected at about the same time, but one cannot state with any certainty what was initially envisaged for the Upper Battery site.

The 1892 plan of the Lower Battery emplacements is quite close to the work as built. A comparison with the record plans of the fort shows that the major additions were the DRF pedestals, the SAA store and the water tank. The drainage system was also slightly different.³ The construction work on both batteries was carried out between 1895 and 1898, with most of it being done in 1895-97.⁴

The basic fabric of the batteries as they now stand dates from this period. Subsequent work has consisted largely of the addition of various temporary buildings and, in most cases, the subsequent removal of same. There are several reasons for this comparative stability, not the least being the permanent nature of the work done in the 1890s and the parsimoniousness of all Canadian governments between 1906 and the late 1930s. It takes money to destroy

or alter concrete construction.

The purpose of the present chapter is to provide a chronological inventory of all structures known to have existed in both batteries. This is the only place where non-extant structures will be treated in this report. Further information on the extant buildings will be found in the following chapter. A brief inventory of the on-site armament (excluding small arms) is also included.

Upper Battery Inventory

1895-98

Most of the extant structures on the site were built in this period: emplacement and associated features

subterranean area, stairs, lamp room, shelter,
cartridge store, shell store, artillery store,
etc.

DRF pedestal and niche

parapet wall

surface gutter

guard house

defensible wall

water tank⁵

1903-05

The electric light directing station and the telephone exchange were both added in this period.⁶ Neither of these buildings is particularly well documented. The former was primarily concerned with the working of the defence lights and it is possible, though by no means certain, that the communications needs of the directing station were

responsible for the erection of the telephone exchange. Neither had much connection with the battery in which they were placed. The directing station was not even manned by the same unit as the rest of the battery, since the searchlights were an engineer responsibility.

1906-20

As far as is known, there were no additions or removals.

1920-35

There were additional structure(s) constructed in this period but, on the basis of the information available, it is impossible to make categorical statements about it or them. The evidence is as follows:

(1) in 1924, a wooden "skidding shed and B.C. post" was authorized and (apparently) constructed somewhere in Upper Battery.⁷

(2) An inventory of the defences contained in a defence scheme in 1928 included a statement that "The F.C. Post is, by day, at Signal Hill and by night, Rodd Hill, where is situated the electric light control station." The writer went on to state that this arrangement was "unsatisfactory," and to recommend that the two functions be consolidated in a FC post at Signal Hill.⁸

(3) There is no other direct evidence of the nature and position of the work(s) constructed in Upper Battery in the 1920s except for a plan, drawn in 1929, which mentions a "F.C. Post" on the right side of the battery around the DRF niche, but does not show a building in the position.⁹

(4) In 1933-34, an attempt was made to install a position finder (PF) at Rodd Hill. For this period, we possess a record plan of a "Fire Commander's Post" in Upper

Battery¹⁰ and correspondence on the subject of a PF for the post.¹¹ In January 1934, the District Ordnance Officer was asked when the position finder would be completely installed. He replied that, "owing to the large amount of depot work and the awaiting of stores from England," it would be approximately twelve weeks before the PF would be ready.¹²

(5) A fortress defence scheme from the late 1930s states that the Fire Command Post for the Victoria-Esquimalt defences was at Rodd Hill.¹³

(6) Notwithstanding the above, no surviving artillery equipment list from the 1920s and 1930s lists the 5th Heavy Battery as possessing more than one PF, and that was always listed as belonging to the Eastern Armament District (Signal Hill and Macaulay).¹⁴

(7) Although there are no extant buildings in Upper Battery from this period, the foundations of a building which clearly was the Fire Command Post shown in the 1933 plan are still visible. The most prominent remains are three square concrete pillars which were clearly the foundation of the PF pedestal. We also have conflicting evidence which suggests that a PF might have been present on the site in 1939.¹⁵

This evidence raises more questions than it answers. For one thing, just how many buildings are we talking about: one? two? possibly even three? Or is it perhaps a case of the same building having had a succession of uses? It is possible that additional documentation on the subject will turn up, although this is becoming less and less likely. It is possible that we may be able to untangle the problem through interviews with retired servicemen. At the moment, however, no definite answers are available. One can only say that:

(1) Some sort of building was erected on the right of

the area of Upper Battery between 1924 and 1934. Possibly two buildings were erected in succession on the same site. Possibly two buildings were erected at different times on different sites.

(2) The DRF pedestal was moved at some point in this period when the foundations for the PF pedestal were constructed in front of the DRF niche.

(3) A pedestal for a PF was constructed, although there is some doubt about the date of the installation of the PF itself. It is probable that the pedestal was built in 1933-34 and that the earliest possible date for the installation of the PF was April 1934. This, however, does not explain why the PF never shows up on the equipment lists.

1935-56

According to aerial photographs taken at various times during the Second World War, there were several temporary buildings erected in the battery during this period. Some of these may have been associated with an anti-aircraft gun in the battery (see below, "Anti-Aircraft Guns"). In general we are in complete ignorance about these buildings.¹⁶

After 1944, the fort is usually marked "Fort Dismantled" on plans.¹⁷ Sometime after 1944, the Fire Command Post (the building surrounding the PF pedestal) and all minor temporary buildings were removed. At present, the electric light directing station, the telephone exchange and the foundations of the fire command post and PF pedestal are the only parts of the battery constructed later than the turn of the century.

Lower Battery Inventory

1895-98

All of the extant structures on the site were built in this period: emplacements and associated features

subterranean structures

crew shelters

DRF Pedestals

artillery store

SAA store

guardhouse

defensible wall, firing step, loopholes, etc.

casemate barracks, cookhouse, ablution room.

coal store, provision store, general store

latrines

oil store (casemate barracks)

water tank.¹⁸

Although most of these structures were subsequently adapted for purposes other than those originally intended, the adaptations never caused fundamental changes in the building fabric. There were, however, other buildings constructed in the battery. We have only fragmentary information on most of these. All were subsequently demolished.

Before 1903

The SAA store was converted to a Lyddite shell store.¹⁹ A skidding shed was added just north of the artillery store.²⁰ This latter building, a wooden shed measuring 10 feet by 19 feet, cannot be precisely dated. It may have been built as early as 1896-97. It was not, however, included in the earliest surviving proposal (1892) for the battery.²¹

1906-39

Only minor alterations or additions were made in this period. A lean-to may have been constructed on the south side of the skidding shed.²² The oil store behind the guardhouse was also built in this period, but the exact date cannot be determined.

1939-56

With the outbreak of war, a large number of frame buildings were erected around the Rodd Hill Site, several of them within Lower Battery. In February 1944, these included a QM store in front of the casemate barrarcks, a cook's quarters and mens' mess on the site previously occupied by the skidding shed, and a shed just behind No. 1 emplacement.²³

The cook's quarters and mens' mess appear from plans to have consisted of three connected structures: the cook's quarters being the northernmost of the three, the mess in the middle and a third (unidentified) structure at the south end. The cook's quarters is a new building, but the other two may have been the skidding store and lean-to adapted to other purposes.

Around 1943, a 40 mm Bofors anti-aircraft gun was put in No. 2 emplacement. Some buildings were erected to provide services for it, including a skid shed, a generator shed, a shelter (possibly another shed) for a telephone, one unidentified building and a ramp into the emplacement. All of these were located behind the emplacement except for the generator shed, which was located behind the left DRF pedestal.²⁴ The generator shed was probably built to house the generator needed to run the predictor. There is, however, evidence to suggest that the generator was also housed in No. 3 barrack casemate at one time.²⁵

All of these temporary buildings were removed, most

between 1944 and 1954. The shed behind No. 1 emplacement does not, in fact, show up on the later 1944 plans.²⁶ By 1954, only the QM store building remained.²⁷ It was removed around 1958.²⁸

Armament

A more complete discussion of the principal armament of the two batteries, the "Ordnance, BL, 6-inch, Mark VI" gun will be found in the chapter on equipment (see below). The purpose of the present section is to identify and date the principal armament present at various periods.

A joint Royal Engineer-Royal Artillery inspection report dated May 1900 identified the three 6-inch guns in the two batteries and their carriages as shown in the accompanying table (Table 1).²⁹ The same three guns and carriages were, as far as is known, always associated with the batteries, but they were not always mounted. In 1914, for instance, the office of the Master General of the Ordnance in Ottawa informed the GOC in MD XI that the Ottawa copy of Army form G 844 (apparently the central inventory of ordnance) had been altered to show that "Ord. B.L. 6-inch Mk. VI. No. 841." was located in the Victoria Drill Hall. The gun was, according to the Master General's office, "Part of the approved armament of RODD HILL, Lower Battery."³⁰

All three guns were apparently mounted through most of the First World War. Thereafter the situation becomes murky again. No one can remember any of them being fired later than about 1924.³¹ From about the middle of the 1920s, a 6-inch QF gun was mounted for drill purposes in front of No. 1 gun in Lower Battery. This appears occasionally in the equipment returns in the RCA inspection reports as "Ordnance, 6" QF on BD Mtg. (Mtd. for drill only)."³² Unfortunately it does not appear on these lists for all

Table 1. Armament and Carriages, 1900 (from an inspection report in FRH file FRH.0082, original source not known)

Guns

Position	Designation	Description	Mark	Registration no.
Upper Battery	A/1	6-inch, BL, 5 tons	VI	841
Lower Battery, right	B/1	ditto.	VI	842
Lower Battery, left	B/2	ditto.	VI	844

Carriages

Upper Battery			IV	A791
Lower Battery, right			IV	A792
Lower Battery, left			IV	A796

years in which it was known to be on the site. In fact, it only shows up in 1929-30 and 1935-37.³³ In the same period, the old disappearing guns are all listed as present in every year from 1927 to 1938, although there is some doubt about this too.³⁴

The 6-inch Mark II gun mounted for drill purposes in the 1920s and 1930s was a naval gun and was mounted on a naval PII (between deck) carriage.³⁵ No proper emplacement was provided for it, and no trace of its presence is at present visible in Lower Battery. No one who remembers it remembers 6-inch ammunition being fired from it, and it is probable that the mounting would not have stood up to having a round fired. It is likely therefore that the aiming rifle only was used when a crew practiced on the gun.³⁶

All four 6-inch guns were removed between 1938 and 1940.³⁷

Anti-Aircraft Guns

Although air attack was always considered a possibility in the various plans drawn up for Victoria-Esquimalt, there was little action on the subject until after Pearl Harbour. In the aftermath of that shock, machine gun anti-aircraft defence was improvised all over Victoria and Esquimalt.

This was manifestly inadequate, but the situation could not be remedied immediately, and as late as March 1942, there were still only two 3.7-inch anti-aircraft guns and five 40 mm Bofors in all of Esquimalt and environs.³⁸

In the course of 1942, additional AA guns were dispatched to the west coast and plans were drawn up for their disposition. Unfortunately, the plans were rarely followed. Thus, in May 1942, a proposal for the placement of the heavy (3.7-inch) AA guns was put forward in which it was envisaged that no fewer than four of them would be

located at Rodd Hill.³⁹ A few weeks later, a similar plan was drawn up for the light (40 mm) guns in which Rodd Hill was ignored altogether.⁴⁰ While the plans were being made, however, the guns were being allocated on an ad hoc basis. The day after the light AA proposal was sent, it was acknowledged that two of the Bofors guns were in fact mounted at Rodd Hill.⁴¹ And there, despite the plans, one of them stayed.

Sometime between the summer of 1942 and the summer of 1943, the existence of the Bofors was recognized and the two sites officially designated VL1 and VL2. Unfortunately, we cannot be absolutely certain where both sites were. As VL2 remained operational for the remainder of the war, and as we know that it was located in No. 2 emplacement in Lower Battery in the following summer (1944), the temptation is to say that it was located in that position throughout the whole period. As for VL1, the discovery of its location awaits some research among the veterans who served at Rodd Hill during the war. It may have been located in Upper Battery.⁴²

VL1 may in fact, have never been operational at all. In August 1943, the Officer Commanding the Esquimalt Fortress requested permission to move the gun from site VL1 because it was "considered spare, and solely in its present position for training purposes." He therefore felt the gun could be better employed at the naval oil jetty. His argument was accepted and the gun was moved.⁴³

This left VL2. In February 1944, an inspecting officer (Major General Archibald) declared that it was a "good site" manned by a "keen detachment." His inspection also revealed that site VL2 possessed, in addition to the gun, two oil units, one generator, one predictor, one F.A.S. and one check sight. All of the equipment was located at the gun (some of it in temporary buildings) except for the

generator. This may have been in one of two places: either in a wooden generator shed located just behind the left DRF pedestal in Lower Battery or in No. 3 barrack casemate.

Some people remember it in the casemate and the casemate does, in fact, still bear traces of having had a generator mounted in it.⁴⁴

Major General Archibald did not mention a second AA site at Rodd Hill. Notwithstanding this, a photograph taken less than a month after the inspection shows two 40 mm Bofors at Rodd Hill. In addition to the one in No. 2 emplacement, a second is shown near the sergeants' quarters and mess near the main gate from Belmont Road. It is not clear how long this second gun remained in this location.⁴⁵

General Archibald recommended, among other things, that the numbering system of the Esquimelt light AA batteries be changed. As a result, VL2 was renumbered VL1 and, as VL1 remained operational until around the end of the war. It was abandoned in the summer of 1945. It is not clear exactly when the gun was removed.⁴⁶

This did not, however, mark the end of the anti-aircraft gun story at Rodd Hill. Shortly after the war, the defence department began to investigate the possibilities of acquiring a dual-purpose coast/anti-aircraft gun. The British 5.25-inch gun was selected for trial and a proposal was made to install one of these guns on a site somewhere in the Victoria-Esquimalt area. Initially, the gun was only intended for training purposes in the anti-aircraft role, but it was eventually intended to use it for training in a coast artillery role as well.

The main problem with this proposal was that no one could agree on a site for the gun. Macaulay, Rodd Hill and Albert Head were all proposed. Headquarters for the British Columbia area favoured Rodd Hill, and at one point a

location was chosen and an estimate drawn up for the construction of an emplacement. The site in question was in Upper Battery well east of the old HP emplacement.⁴⁷

Unfortunately, the documents covering the conclusion of this story are still in the possession of the Defence department. It is sufficient to say that the emplacement at Upper Battery was never built. It would seem that one was constructed at Macaulay, but it is not clear whether the gun was ever mounted.⁴⁸

The anti-aircraft gun(s) were not a negligible part of the Rodd Hill story during the Second World War. But no permanent traces of the presence of anti-aircraft equipment remain in either of the batteries, except for a few almost invisible bits and pieces here and there (the ducts for the generator cables in No. 3 casemate, for example).

Conclusions

It would seem that, even in relatively simple matters of building and armament chronology, there is still a good deal of ambiguity about events at Rodd Hill. We can, however, use the available information to date all but one of the extant structures or remains (the one exception is, of course, the foundation of the FC Post). We can also use the available information to determine the compatibility of the extant structures with any given time in the history of each battery.

The accompanying tables (Tables 2 to 4) attempt to do this last. Three facts must be taken into account in examining them. First, these tables only deal with historical facts. In attempting to enumerate the changes necessary to restore the physical appearance of the battery to a specific period, no compromise solution is recognized (i.e. "structure x must be removed" instead of "structure x

must be ignored"). Second, only the physical appearance of the structures is taken into account. No account is paid to what we do or (more commonly) do not know about the interiors. Finally, in these tables, the presence of 6-inch guns on a HP carriage is assumed for any period prior to 1938-40. Without these, the earliest historical period that can be depicted in the batteries is 1938-40, except in Upper Battery where the gun was definitely not mounted in 1914 and possibly for a few years before that.

As can be seen, the extant structures are most compatible with the period 1905-20. Selecting this period would involve a minimum of alteration or reconstruction. In the case of Lower Battery, anything from 1898 to 1920 is acceptable. In Upper Battery, any period is fraught with difficulties, but, in the main, the pre-World War I period is best, with ca. 1905-06 as the earliest recommendable date.

The criteria used in coming to these conclusions about compatibility of extant structures are not, of course, the only ones which could be applied. It is apparent that even from an historical point of view others are equally valid (building use and importance to the overall story of the fort are two which come to mind). Within the criteria of physical compatibility to various time periods (the periods themselves being defined by the physical evolution of the site), it is difficult to escape or deny the conclusions shown in Tables 2 to 4.

Table 2. Upper Battery: Dating of Extant Structures and
Condensed Notes on Building Compatibility

Extant Structures: All date from 1895-98 except the electric light directing station (1903-04), the telephone exchange (ca. 1904-05) and the ruins of the FC post(?) (ca. 1933?)

Optimum documentation: As regards structure, no period is adequately documented. The closer we get to the present, the greater is the likelihood of being able to find answers to specific questions through an oral history program.

Latitude in dating with present structures (external appearance only):

- (1) ca. 1905 to ca. 1920 (if remains of FC post were removed)
- (2) ca. 1956 to present

Additional structures required or removals necessary if structures are to be made compatible with any other period:

- (1) before 1905: removal of electric light directing station and telephone exchange.
- (2) the exact requirements of any other period cannot be determined on the basis of information now available.

Table 3. Lower Battery, Casemates: Dating of Extant Structures and Condensed Notes on Building Compatibility

Extant structures: All date from 1895-98.

Optimum documentation: See comments for Table 2. The casemates are, in fact, the worst documented part of the fort.

Latitude in dating with present structures (external appearance only):

- (1) 1898-ca. 1939
- (2) ca. 1956-present

Additional structures required or removals necessary if structures are to be made compatible with any other period:

- (1) For any period between ca. 1939 and ca. 1956, a wooden QM store building would have to be reconstructed in front of the casemates.

Table 4. Lower Battery, Emplacements: Dating of Extant Structures and Condensed Notes on Building Compatibility

Extant structures: All date from 1895-08; except the small oil store.

Optimum documentation: See comments for table 2.

Latitude in dating with present structures (external appearance only):

- (1) ca. 1954-present.

Additional structures required or removals necessary if structures are to be made compatible with any other period:

- (1) ca. 1898-ca. 1924: a skidding shed would have to be reconstructed and the oil store (probably) would have to be demolished.

- (2) ca. 1924-ca. 1941: in addition to the skidding shed, a QF 6-inch Mark II gun on a naval PII mounting and (probably) a lean-to addition to the skidding shed would be required.

- (3) ca. 1942-45: Cook's quarters, mens mess (which may have been the same structure as the old skidding shed), buildings and equipment associated with a 40 mm AA gun and a 40 mm AA gun would be required.

- (4) 1945-54: all of the buildings mentioned in item 3 above were removed in this period, but it is not known exactly when.

Structural Notes

Introduction

The purpose of this chapter is to provide general structural information on the various component parts of the batteries. Given the nature of the evidence, most of the discussion is of a very general nature, but it is hoped that even this will provide some insight into the intentions of the engineers who built the batteries and answer a few questions about specific parts of the design.

Only extant structures are treated in this section.

Emplacements: General

The emplacements for the 6-inch Mark IV carriage were of two standard types: semi-circular and all-round. There were few deviations in the standard design of each of these types.

In both instances, the upper part of the emplacement overhung the lower, and in both instances the upper radius of the emplacement was 8 feet 9 inches and the lower 9 feet 9 inches. In both types, the racers were: "held down to a mass of concrete about 6 feet deep and 14 feet in diameter, which (was) hollowed out at the centre in order to be able to get at the gear under the mounting." The major difference between the all-round and the semi-circular types lay in the fact that the former required "recesses in the walls in order to use the rammer."¹

In addition to the walls and floor of the emplacement, there was a concrete apron or glacis. In the all-round

emplacement, the apron surrounded the pit. In the semi-circular type, it was U-shaped and ended at the parapet wall. In both types, the apron was a thick slab of concrete sloped gently away from the opening of the gun pit.

Textbooks of the period do not agree on either a standard thickness or a standard depth for an apron, conditions at each site being the determining factor in its dimensions. Its purpose was to deflect shells and to prevent them from penetrating the side walls of the emplacement.

The shell of the standard emplacement consisted, therefore, of three closely-connected features: the concrete pad on which the gun rested, the side walls and the apron. The concrete pad was connected to the side walls by a thin stretch of concrete. It was usually virtually impossible to distinguish between the side walls and the apron except where the apron was comparatively shallow and did not extend to the bottom of the side wall.

In both semi-circular and all-round emplacements, the holding-down bolts for the carriage were arranged in two concentric rings. Each bolt was 5 feet long. Standard procedure was to embed them in the "Portland cement concrete" of the pad at the time of construction.²

Standard dimensions for the pit in the centre of the emplacement were 3 feet 7 inches maximum radius with a maximum depth of 3 feet below the level of the racers.³ The bottom of this pit was a slightly deformed oval in shape.⁴

Two features were traditionally built into the emplacements: recesses of various sorts and ring bolts. The former were for storage of shells, cartridges, fuzes, tubes, various gun stores, placement of range dials, etc. The latter were to provide permanent holdfasts for repository drill and for moving the gun. The engineers had a certain amount of discretion in the placement of both these features, but certain general rules applied. The ringbolts,

for instance, had to be placed 3 feet above the floor of the emplacement and countersunk.⁵ It was standard practice to provide five of them for a 6-inch HP emplacement.⁶ The standard ringbolts were 2 feet 10 inches long with a 7-inch bolt.⁷

By 1893, recesses were of several sorts:

Recesses for cartridges may be made 3 feet 9 inches wide, 3 feet 9 inches deep and 5 feet high. They would be closed with a strong wooden door barred with iron.

A recess for small stores belonging to the gun is convenient but not necessary. It may occupy a similar position to the cartridge recess and be the same size or rather smaller and have a shelf in the middle.

Shell recesses have no doors and are usually arranged around an emplacement at floor level. Their dimensions depend on the size of shell to be accommodated...

Small recesses should be provided for keeping tubes and fuzes handy to the gun in action, at least two to each gun. They should be 20 inches long and 8 inches high and deep and be 4 feet 6 inches from the floor.

Several recesses of this character may be provided as they are convenient for depositing various small articles for use about the gun.

The dial recess is one of the fittings for Position Finding.... It is made like a cupboard, 3 feet wide, 1 foot deep and 5 feet 6 inches high, closed by a door. It should as far as possible be kept clear of the ammunition service....⁸

Emplacements: Rodd Hill

Not surprisingly, the 6-inch HP emplacements at Rodd Hill followed the standard design almost to the letter. The same is true of the emplacements at Macaulay. Only four points need to be noted:

(1) In neither battery at Rodd Hill is the emplacement the standard "U" shape, as is the case at Macaulay. At Rodd Hill, the walls of the emplacement are flared slightly at the gorge. In addition, the emplacement at Upper Battery is not quite the same shape as the two at Lower Battery. In neither does the overhang continue past the point where the side walls start to flare.

(2) The position of the recesses was, to a certain extent, determined by the relation of the guns to the magazine. This led to some differences among the three emplacements at Rodd Hill. All three had four equal-sized shell recesses arranged around the bottom of the "U" in the front of the emplacement. Each had, in addition, one larger shell recess. In Upper Battery, this was located on the left side of the emplacement towards the rear. In both emplacements in Lower Battery, it was to the right. The dial recess was located outside the emplacement on the parapet wall in Upper Battery with the cartridge recess to its left. In both the emplacements in Lower Battery, the cartridge recess faced the oversize shell recess across the rear of the emplacement while the dial recesses, in each case, were outside the emplacement in the walls on the passages leading to the crew shelters. In Upper Battery, the fuse and tube recess was just above and to the left of the serving hatch, and in Lower Battery the fuze and tube recess for each gun was also near the serving hatch. In addition, each emplacement had a small recess.

(3) Besides the recesses, each battery had brackets for

holding tube and fuze boxes. There were two of these brackets in each emplacement and they were located in the side walls towards the rear on each side. The presence of these brackets may account for the fact that these emplacements have only one fuze and tube recess each and not the two recommended.

(4) All three emplacements had range dial recesses despite the fact that the PF system was never used at Rodd Hill. The same textbook which contains the statement quoted above concerning the use of Dial recesses, however, also notes that range dials were used with DRFs as well.⁹ There is, therefore, some doubt as to what, if anything, the Rodd Hill dial recesses were used for.

Magazines and Subterranean Structures: General

It is technically incorrect to refer to any of the ammunition stores at Rodd Hill as "magazines." The term, in its most specific sense, applies only to a place where gunpowder is kept loose in barrels. Even soldiers, however, use the word to describe a place where ammunition is stored.¹⁰ At Rodd Hill, only the cartridge stores were maintained under magazine conditions (i.e. with rigid segregation of the storage area from its surroundings). But the term "magazine" can be stretched to include all the subterranean structures, since most of them are somehow connected with the storage of gunpowder, and the rules for the construction of subterranean ammunition governed the way in which they were laid out and built.

Three fundamental factors govern the design and construction of magazines. In the first place, ammunition storage has to be convenient to the gun served. In a really large work, this sometimes led to the adoption of a two-tier system with main and subsidiary magazines. More commonly,

it meant that the ammunition for each gun was stored at the gun, or that two guns shared common facilities.

The second fundamental criterion for magazines was bombproofing. This commonly meant that they were subterranean. This, in turn, exacerbated the problems created by the third fundamental criterion: magazines had to be dry. The construction of a dry subterranean magazine was one of the more vexing problems of military engineering.

This problem had two aspects: percolation (simple leakage) and condensation. The best defence against the former was to build the magazine properly in the first place. Several methods were commonly used by the Royal Engineers to ensure a staunch magazine. These included the use of asphalt and cement as staunching materials, the construction of hollow walls and the use of air spaces and drains.¹¹ The most common arrangement of materials in magazines was this: brick inner fabric, concrete outer fabric and earth cover. The possible variations in arranging rooms and the deploying of materials and damp-proofing materials within this basic framework were, however, almost limitless.

If percolation was fundamentally a construction problem, condensation was chiefly a function of air circulation (or lack of same). In addition to the precautions taken against percolation, therefore, it was necessary to provide for air circulation in the magazine and also to prevent air from entering the magazine on damp days.

This could be simply done by using a 9-inch glazed pipe.

More commonly, an air shaft and louvered ventilator were used.¹²

One writer in 1890 summarized the rules for magazine construction as follows:

The foundations must be perfect so that there shall be no settlement.

There should be a damp course over the whole area.

The exterior wall should be hollow except sometimes in rock. It should also be rendered and foot drained.

Sometimes the interior wall should be rendered and drained also.

The concrete over the arches should be asphalted and drains laid to carry away the water coming off it.

The arches should have a damp course at the springing.

The interior of the magazine should be of some non-conducting absorbent material, say brick.

The ventilation should be as free as possible when it is acting.

The ventilation of the magazine chambers and of the air passage should be entirely distinct.

The magazine should be in such a position that it may be possible to get at the exterior to repair it.¹³

Magazines and Subterranean Structures: Rodd Hill

We have only the record plans to go by in any structural discussion of the subterranean works at Rodd Hill. It is, therefore, a difficult subject to discuss. In light of the general information on the construction of subterranean magazines, the following is obvious:

(1) In neither Upper or Lower Battery was anything like the whole gamut of construction techniques outlined in the 1890 textbook put to use. Comparison with cartridge and

shell stores constructed at other works - Forts Ogilvie and Cambridge at Halifax for example¹⁴ - reveals that the design employed at Rodd Hill is fully comparable to the standards in use at other 6-inch gun works of the period.

(2) It is also clear that the engineer (or engineers) who designed the work took an entirely different approach to each battery as the construction arrangements in each are not very similar. The magazines at Macaulay are also different, as least insofar as layout goes, but the basic mode of construction is the same as for Upper Battery. I have not been able to find another work built exactly like the Lower Battery magazine.¹⁵

(3) In Lower Battery, the designer appears to have been principally interested in the cartridge store. The arrangement of the ammunition and lamp passages completely isolates the store from the concrete shell of the subterranean part of the work in all but three places: the point where the lamp passage wall joins the concrete wall and, of course, the floor and ceiling of the store. The side walls and arch of the store are brick, as is the east wall of the lamp passage. Every other wall is concrete. This arrangement provides maximum protection (by Rodd Hill standards, if not by the standards of the 1890 textbook) for the cartridge store, while the rest of the underground structures have minimum protection from damp by any standard.

(4) In Upper Battery, no attempt was made to isolate the cartridge store by the provision of a lamp passage, although, interestingly enough, this would have been possible by constructing the whole underground complex a few feet further west to make room for a lamp passage between the cartridge store and the emplacement foundation. Instead, all the underground rooms were brick arched and lined and an air space was left between the brick lining and

the outer concrete shell. This space ran from the floor to at least the springing of the arch and possibly higher on the end walls. Evidence of this space, besides the evidence of the record plans, can be seen by examining the position of the ventilators in the work. These occur regularly at points where the brick wall meets the concrete fabric. In addition, the hollow is visible behind the west wall of the crew shelter.

(5) In both batteries, the outer surface of the concrete shell of the underground structures was coated with 0.75-inch asphalt on top and between layers of concrete on the floor.

(6) The most likely explanation for the differences in construction is that the engineers felt that there was sufficient natural drainage at Lower Battery that damp would not be a problem.

(7) In both batteries, ventilation was by means of pipes leading from each room to a common louvered ventilator on top of a square concrete shaft.

(8) In most of Lower Battery, the concrete outer wall and the asphalt were all that prevented percolation. Although it cannot be dated, the metal used in places in both batteries (but especially along the arch of the main ammunition/shell store in Lower Battery) was probably installed at a later period as added protection against percolation. That it was installed at all suggests to me that the engineers and the artillerymen who actually looked after the place, did not consider condensation a serious threat.

(9) Both had reputations as dry magazines.¹⁶ This suggests that the staunching and ventilation methods adopted worked.

The Casemate Barracks

It is very difficult to write about the structure of the casemate barracks and adjacent buildings in Lower Battery. To begin with, it is by no means clear why the structures in question were called casemates. A casemate, by definition, is an underground structure, almost invariably under the ramparts of a fort, usually arched and frequently combining a defensive role with some other function, generally accommodation or storage. The "casemates" at Rodd Hill are none of these things. Earlier, during the smoothbore era, there had been a more or less standard size for casemates. By the time Rodd Hill was designed however, casemates were almost a thing of the past, and those that were most common were designed for RML forts to take a piece of ordnance. Since, in this situation, the size of the casemate depended on the size of the gun to be accommodated, there was, in 1894 no longer a "standard casemate."¹⁷ The Rodd Hill "casemates" do, however, more or less conform to the dimensions of casemates of the smoothbore era, leading one to suppose that the Rodd Hill casemates were so called because, somewhere in the barrack regulations, there was an (out-of-date) clause defining the term in terms of room size. As, however, no copy of the barrack regulations for the right years is conveniently available, this is pure speculation.

The origin of the name is, however, the least of our problems. The fact is, that of the major components of Fort Rodd Hill, these are the least well documented and described. Even the engineer record plans of 1903 are, for a change, scant consolation, since they provide only a single plan and two sectional elevations of the accommodation area in Lower Battery.¹⁸ The only other plan which shows the work in section may well have been drawn before the work was complete and is, in any case, not a

record plan and should be treated with caution.¹⁹

Finally, the secondary literature is of no help at all. Contemporary fortifications textbooks treat the subject of casemates in the section on RML fortification and this, alas, is of little use to us.²⁰

The search for comparative buildings in other works has not, however, been entirely fruitless. There is nothing quite like the Rodd Hill casemates elsewhere in Esquimalt, but there are two structures in Halifax which are similar. One is a crew shelter in Point Pleasant Battery and the other is a crew shelter in Cambridge Battery.²¹ Although the latter is, in fact, partially underground, neither is called a casemate. Nonetheless, they do have points in common with the Rodd Hill barracks.

The most obvious point of similarity among the three buildings is their width and the use of girders. All three are 14 feet wide (on the inside) and all three have iron or steel roof beams. In both Rodd Hill and Point Pleasant, the beams are about 3 feet apart. Point Pleasant is the only one of the three works for which we have sections, and this would seem to indicate that there are no vertical steel girders. There is no obvious reason why all three structures should have been 14 feet wide. Possibly there was something in the regulations. More likely, the iron (or steel) beams came in standard lengths and the engineers designed their rooms accordingly.

Apart from what can be deduced from the record plan of Lower Battery, from the (possibly unreliable) accommodation plan of 1897, and by comparison with the plans of the similar structures in Halifax, there is little the historian can offer by way of structural information on the casemate barracks. The only place when some helpful material might be available is in the matter of roofing material. It is nowhere specified what was used on the roof of the

casemates. The only way to find out anything on the subject is by the examination of existing remains on the roof. A 1934 contract specification for a tar and gravel roof for a concrete building is available and might provide some insight into the question.²²

As for the smaller buildings in the Lower Battery barrack area, it seems futile even to attempt to write about them.

Other Extant Structures

The same considerations which apply to the small buildings in the casemate barrack area apply to the other structures in the work. None belongs to any category of specialized structure for which there is a precise definition of size or shape. From the point of view of a written structural history, there is little to be said about them. Most of them are simply concrete shells.

We are a little better off with these buildings than we are with the smaller buildings in the casemate barracks, for at least we have both record plans and sections of all but the telephone exchange. These might not tell one all one wants to know, but as far as historical fact goes they are almost all we have.

To enumerate briefly:

(1) Upper Battery guardhouse: concrete structure with a wooden verandah and latrine attached on the west side. We possess a record plan, two record plan elevations and several historical photographs.²³ No structure elsewhere has been selected for comparative purposes, although some obviously exist. The work has suffered no major structural changes since its construction although, at some point, the wall and ceiling have been badly cracked. We have not yet succeeded in dating this damage.

(2) Lower Battery guardhouse: concrete structure with iron or steel ceiling beams, wooden verandah and latrine attached on the west side. We have a record plan and section of this work and historical photographs.²⁴ No structure elsewhere has been selected for comparative purposes, although some obviously exist (in fact, the construction of this building is similar to that of the casemate barracks, q.v.). There have been no major structural alterations to this building except for some changes in the latrine which, during the Second World War, was properly roofed over and modernized.²⁵

(3) Small arms artillery store: Concrete structure with iron or steel ceiling beams. We have a record plan, section and elevation of this building.²⁶ The cook house, ablution room, telephone room and officer's room in Point Pleasant Battery in Halifax are all relatively similar in construction (see Fig. 18).²⁷ Although this building was converted early to a Lyddite shell store, the conversion involved no major structural change and the building is still much as built.

(4) Artillery store, Lower Battery: The same considerations which apply to the SAA store apply to this except for the fact that it was not converted into a Lyddite shell store.

(5) Electric light directing station: concrete structure with iron or steel ceiling beams. We possess a record plan and section of this building.²⁸ There have been no major structural alterations since construction.

(6) Telephone exchange: very little documentation. It seems likely, however, that it looks and is much the same now as when erected.

(7) The walls: It is doubtful if anything whatever has been done to or with the walls and embrasures since the day they were built.

Building Interior Notes

Introduction

As with the structural notes, an unfortunately large portion of this section is confined to generalization. To begin by stating the obvious, building interior largely depends upon building use. At Rodd Hill, it is very difficult to pin down what, if anything, was going on in a particular structure at any given time.

Some buildings are easier to describe than others. For convenience, the buildings in this chapter are divided into two classes: fixed-use buildings and variable-use buildings. The former are structures whose use was so specific that they saw little or no change throughout the entire operational history of the batteries. In most cases, we know enough on the basis of current work to restore the interiors. Of the variable-use buildings, it can be safely said that we do not know enough about them to do much of anything with them; that it will be difficult to assemble the information which will allow us even to trace the various uses to which the buildings were put; and that considerable additional research is necessary before we even get that far.

In general, the fixed-use structures are those associated with the guns, while the variable use structures are those used for housing, the care of stores or (unfortunately) both. The contents of the former tended to be static for years, while in the case of the latter there is some difficulty in determining whether they ever had any

contents at all. Table 5 lists the buildings in each category.

As before, only extant structures are treated in this chapter. In the case of the fixed-use structures, only the basic interior fitments are treated here. A provisional list of the contents of many of these buildings will be found in the chapter following. In the case of the variable-use buildings, the notes in this chapter are intended to spur on further research.

As before, information from secondary sources is, where appropriate, incorporated into the text.

Fixed-Use Buildings

Lamp Rooms

These were simply rooms where the lampman could store his lamps, clean them, and keep any spare parts, lamp-cleaning materials, candles, etc. which might be authorized for the work. At Rodd Hill, the lamp rooms were included among the underground structures at both batteries.

Lamp rooms commonly contained only "some shelves for the lamps and a bench or shelf at which they can be cleaned."¹ At Rodd Hill, there is an extant bench and shelving in Lower Battery lamp room. The bench is almost certainly original and the better-constructed part of the shelf probably is also. The bench could be used as a model for the lamp room in Upper Battery, although a bench of this size would block the lower part of the window. It is obvious, however, that any reasonably-sized bench would block the lower part of the window in Upper Battery lamp room.

The major difference between the two lamp rooms at Rodd

Table 5: Fixed and Variable Use Buildings

<u>Fixed Use</u>	<u>Variable Use</u>
cartridge stores	casemates
shell stores	guardhouses
shifting lobbies	cook house
lamprooms and lamp recesses	ablution room
artillery stores	provision store
Lyddite/SAA Store	general store
Oil stores	(crew shelters)
emplacement recesses	
electric light directing station	
telephone exchange	
(crew shelters)	

Hill is the presence of panelling on the wall in Lower Battery. This is almost certainly because the lamp room in Upper Battery is brick-lined and the walls of the Lower Battery lamp room are bare concrete. There is no reason to suppose that the Lower Battery lamp room panelling is not original, nor is there any reason to suppose that the walls of the Upper Battery lamp room were ever panelled.

Lamp Recesses

These were designed to allow the safe use of candle-powered lamps in an area where ammunition was being handled. Not surprisingly, both the fortifications textbooks and (presumably) the magazine regulations had a great deal to say on the design of proper recesses - too much, in fact, to quote here.² A lengthy discussion of this topic has therefore been confined to Appendix A.

As for the recesses in Rodd Hill, the nature of the frames and locks can be deduced from a study of this appendix. The surviving frames in the lamp recesses on the site are almost certainly original.

For the record, the types of recess at Rodd Hill are distributed as follows:

	Wall Recesses	Passage Recesses
Upper	2	3
Lower	3	3

Shifting Lobbies

These served to isolate the magazine or ammunition store from the rest of the work. They were commonly provided for powder magazines and cartridge stores and they usually consisted of a hinged barrier across the only passage leading to the magazine, with clothes racks and seating on

either side and a foot scraper on the outside (i.e. non-magazine side) of the barrier. Technically the magazine began just inside the barrier.³ The arrangement of these lobbies varied slightly from place to place but, in general, they all resembled the one shown in Figure 19, and the two at Rodd Hill were no exception.

The surviving wooden features in the Rodd Hill shifting lobbies are either original or (less likely) copied from the original. Using them as patterns, there should be little difficulty restoring these rooms.

Cartridge Stores

These were simply chambers in which cartridges were kept under magazine conditions (i.e. shifting lobby, special clothes provided, standard safety precautions in force, etc.). At the time Rodd Hill was designed, cartridges were commonly stored in zinc cylinders which were usually "piled three high" in store. The size of a cartridge store required for a work was determined by calculating the amount of space required for the authorized cartridge allowance of the gun(s).⁴

While this calculation may have determined the size of the cartridge stores designed for Rodd Hill, there is every evidence that the cartridges actually in use at the batteries were shipped and stored in wooden cases (see following chapter). (On the record plans, in fact, the capacity of the Upper Battery Cartridge store is computed in cylinders and that of the lower cartridge store in cases.)⁵ This makes the question of interior fitments in the stores a very simple one; as the cases required, at most, some kind of wooden flooring between the bottom row of cases and the bare concrete and, conceivably, might not have had even that. Apart from cartridge cases and rudimentary flooring,

there would have been nothing else in the store.

The doors of both cartridge stores are probably original, as are the doors of the issuing hatches in both.

Shell Stores

The rules for the design of these were quite loose:

The requirements to be met by a shell store are few in number:

They are shelter from rain...; security against the plugs of shells being unscrewed...and protection against direct blows of an enemy's projectile.⁶

No special arrangements were necessary, and the only other factor involved (beyond those outlined above) was the provision of ample space for the authorized allotment of shells for the gun or guns served by the shell store. As all shells from 6-inch up were simply stored on end, this was a simple square-foot calculation. A 6-inch shell, incidentally, occupied 0.2500 sq. ft.⁷

As of 1890, no wooden flooring for shell stores was considered necessary, it being considered that shells could stand on bare concrete. There was, however, no absolute prohibition against providing of some sort of flooring for the shells and it was common practice to do so.⁸

Shell stores were not, of course, the only place where the shells might be kept. The recesses at the gun were intended to hold a number of shells, but generally only when the gun was being used for drill or when it was considered necessary to keep ready ammunition at the gun.⁹

Two quite different arrangements were used in the shell stores at Rodd Hill. In Upper Battery, a proper room was set aside for the purpose, while in Lower Battery, the ammunition passages were used. The racks currently in use

in the inclined part of the main ammunition passage to hold the shells are probably original. There is no question that something was necessary to hold the shells and there is no evidence of anything other than the existing racks. It should not be forgotten, however, that the whole of the ammunition passage as well as the east side of the main entrance lobby was intended for use as a shell store.¹⁰ There is no evidence of how the shells were arranged in these places, but they probably sat on some kind of boarding.

In Upper Battery, the room designated in the record plan (and in which the shells are now kept) was intended as the shell store, but the shell store changed places with the artillery store next door, probably quite early on in the history of the work.¹¹ The change is logical when one thinks about it, since the designated shell store gets a lot more natural light than the designated artillery store and natural light is useful for the latter and superfluous for the former. This of course, accounts for the presence of the bench in the room presently in use as a shell store; it belongs in the artillery store. As for the boarding under the shells as now installed; this is not original, but its presence is probably not too inaccurate.

Ammunition Passages and the Transport of Ammunition

When Rodd Hill was designed, the use of shell lifts was already common. In smaller-calibre batteries, however, the use of lifts was discouraged. The preferred arrangement was a covered gallery between the ammunition stores and the gun emplacement and it was preferable

if the dimensions of the battery admit of it,
to ramp (the gallery) up at a slope not steeper
than 1 in 7, so that the gallery floor ends at
a level three feet below the floor of the

emplacement. A hatch at this height is convenient for passing out cartridges, while shell(s) can be wheeled up to it.¹²

This could, in fact, be a description of the ammunition passages at Rodd Hill.

These passages had, of course, to be kept clear at all times. If sufficiently wide, they could, however, also be used for other purposes. The use of the Lower Battery ammunition passages as a shell store has already been noted. In addition, the passage in Lower Battery has evidence of some sort of rack or bracket having existed on the west side of the main lobby. There is no real indication what exactly this was used for. One veteran has suggested that fire buckets were hung there.¹³

The ammunition passages existed for removing the ammunition from the magazines. Ammunition was brought into the magazines by the main door. In Lower Battery, this presented no problem, as the door was at ground level, but in Upper Battery a davit was required. The davit also provided an alternative method of getting ammunition to the gun. This was, in fact, a fairly common arrangement in forts:

It is occasionally convenient to hoist ammunition up by the rear of the rampart, or out of an area in front of a store. In that case, a davit can be used...made of round iron, pivoted, and having an overhang of 3 feet, and with an eye at the end to take the hook of a block. It can be 2 inches in diameter to lift 1-1/2cwt, but must be increased to 3-1/2 inches to lift 8 cwt.¹⁴

A standard pattern davit is shown in Figure 20.

Miscellaneous Fitments (Underground Structures)

The underground portions of both Upper and Lower Batteries had a small arms rack fitted near the main entrance. In Upper Battery, it was located to the south of the area steps while in Lower Battery it was across from the lamp room. The Lower Battery specimen still exists, is probably original, and can be used as a pattern.

Artillery Stores

These were of two sorts: general artillery stores and artillery stores for small stores.¹⁵ Those at Rodd Hill were of the second sort. These have been described as follows:

Artillery stores for small stores take such articles as sights, elevating arcs, breech pieces of B. L. guns and other removable fittings....

B.L. guns require a bench, a shelf, and a row of pegs. The bench should be 2 feet 6 inches wide and 3 feet above the floor; the space underneath being closed to form a cupboard. The shelf should be one foot wide and two feet above the bench. The pegs six inches apart below it....

In addition for each nature of B. L. gun in a battery, there should be a space equal to that for one gun where spare breech screws can be stored on the floor, with a cupboard over for oil rag, waste, etc.

A 6-inch B.L. gun requires 3 feet 6 inches run of shelving.¹⁶

At Rodd Hill, it is clear from the above description that the designers did not exactly follow standard practices

for artillery store design. For one thing, the store in Upper Battery is too big for the size of the work. The most likely explanation for the size of the Upper Battery store is that, having made the decision to include the store with the other underground structures, the size was dictated by the space available and, specifically, by the dimensions of the adjacent structures. Certainly no artilleryman would have objected to having the extra space.

The other differences between the above description and the Rodd Hill artillery stores are too numerous to mention. Fortunately, this does not pose too much of a problem with regards to Lower Battery, where most of the internal fitments have survived and are probably original. In Upper Battery, however, there is a problem arising from the reversal of the artillery and shell stores (see above, shell stores). It is clear from examination of the designated artillery store that it was, in fact, fitted out as such when the work was built. The bench currently in the "shell store" may even be the original bench, mutilated slightly when it was detached from its original position next door. It is not, however, clear how many of the fitments of the artillery store were duplicated in the shell store when the transfer was made (i.e., were pegs stuck in the walls?). Nor of course is it possible to arrive at a precise date when the switch was made. It is quite possible that while the bench and most of the stores were moved, the brushes and staves and similar implements were left hanging over the shells.

Emplacement Recesses

The only problems here are the doors and, as patterns exist around the three emplacements of all doors and their ironwork, it is not a serious one (see also above,

Emplacements: General).

Lyddite, (SAA) Store

It would appear that the same general considerations which applied to shell stores also applied to Lyddite shells. As a Lyddite shell store, therefore, this building presents few problems, as there would probably have been little in it except the shells and (possibly) duckboards.

As anything other than a Lyddite store, however, this building presents problems. As a small arms ammunition store, its interior would be difficult to describe. As for the later period in the history of this building, we do not know what (if anything) it was used for after the Lyddite shells were removed, or even at what date the shells were removed. For this period, therefore, the building probably ought to have been placed in the variable use category.

Electric Light Directing Station

The physical layout of the interior of this building can be found by consulting the record plan.¹⁷ Indeed, comparison of the record plan with the building as it now exists reveals that, with regards to the shelving and wall boarding, it has not changed much since it was built.

Telephone Exchange

Next to nothing is known about this building.

Oil Store (Lower Battery)

It is not possible to date this building precisely. It may have been erected as late as the 1920s. Its interior

fitments have almost certainly changed very little since it was built.

Crew Shelters

The purpose of the crew shelter was twofold: to provide bombproof cover for the protection of the crew, especially for wounded men in the event of action; and to provide shelter for the gun crew during gun practice and while manning an operational gun. As such, they were spartan affairs containing little furniture - possibly only a bench.¹⁸

The two crew shelters at Lower Battery were very simple structures. The most either would have been provided with would have been a bench, possibly not even with that.

The shelter in Upper Battery is another matter. One suspects that its size was at least partly determined by the amount of space remaining in the magazine area once the necessary features had been provided for. It is not clear otherwise why it is so big. It is even less clear what, if anything, it was furnished with. Possibly it was empty most or all of the time. The only person so far interviewed who has any specific memory of the place, thinks it was empty and used occasionally for other purposes, such as shell inspections.¹⁹

Variable-Use Buildings

This section is not so much part of a structural history as a confession of ignorance and, hopefully, a guide to the measures necessary to remedy this state of affairs.

There are several problems with the buildings that have (somewhat arbitrarily) been lumped in this category. For one thing, it is apparent, even after limited research,

that few of them were ever consistently used for the purposes for which they were designed. Secondly, it is now obvious that most of the standard primary sources (i.e. archival records) cannot be counted on to provide more than a few clues as to what these structures were used for. Thirdly, this lack of information makes it impossible to assign such a description as "typical" to the guardhouses, barrack casemates, etc. There is, in fact, every evidence that few of the structures in question were ever typically anything.

Thus, in a cursory survey based on the recollections of three people, the following facts emerged:

(1) For most of the 1930s, the guardhouse in Upper Battery stood empty except in summer, when the permanent force artillery arrived for summer camp and ousted the married member of the outfort detachment (who manned the place year-round) from his usual abode in the warrant officer's quarters.

(2) The Upper Battery guardhouse served a number of uses during the Second World War and was finally deserted by 1945 at the latest.

(3) The Lower Battery guardhouse was used, at one time or other, as a lecture room during the permanent forces' summer camp in the 1930s and as an NCO's quarters, a communications centre and a first aid post during the Second World War.

(4) The casemates were used as accommodation for the permanent force during summer camp, and were occasionally used by the district gunner and his gunners during the 1930s. At least some of the mobilization stores for Military District 11 were kept in No. 3 casemate in the same period. Otherwise, there is every likelihood that the casemates were not in use most of the time and were (probably) empty.

(5) Most of the remaining rooms in the casemate barracks may well have been used as intended. There was a range and kitchen shelving in the kitchen. The coal store was actually used to store coal. There may or may not have been provisions in the provision store.

(6) There are a couple of buildings (the general store and the oil store in the accommodation area of Lower Battery) where there is no evidence whatever what - if anything - they were ever used for.²⁰

Three types of research are required before anything ought to be done to the variable use buildings. The oral history program mentioned in the introduction would, in all probability, settle the question of building use back to the 1920s. Research on the units which served in Esquimalt would also shed light on the question. If it is ever proposed to restore and refurnish the provision store, the services of a material culture specialist conversant in the consumer goods of the era desired would greatly simplify things. Finally, a thorough study of the British and Canadian Barrack regulations, sanitary practices, etc. could provide invaluable information.

Equipment

Introduction

The following is a provisonal equipment list. It makes no claim to be complete. It may not, as it will appear, be all that accurate. It ought not to be used as a shopping list for the purchase of materials for the restored fort. It is concerned only with the equipment authorized for the service of the guns; no mention is made of troop accoutrements, barrack furniture, kitchen supplies, etc. It is intended only to give a rough idea of the sorts of materièl which one might reasonably have expected to find in the shell store, the cartridge store, the artillery store, the lamp room, the magazine passages, and in and around the emplacements. It also discusses (briefly) the gun and its carriage and the spare parts authorized for them.

As no equipment lists have survived from the imperial period, this inventory is almost entirely hypothetical. In most instances, we have no evidence that the material here listed was in fact present at Rodd Hill. The source that has been used is the Regulations for the Equipment of the Regular Army. Part 2. - Section XII (a) Royal Garrison Artillery, published by the War Office in 1904.¹ This gives the standard authorization of military stores for batteries. Where possible, the listings in the Regulations were checked against the Priced Vocabulary of Stores issued in 1898.² When an item appeared in both, it was assumed to have been in service continuously from 1898 to 1904.

This method of proceeding is not as arbitrary as at

first appears. A bibliographic search for official British military publications in Canadian institutions has led the author to the conclusion that the two works from which the following lists have been derived are the most relevant to a compilation of this nature, and the time frame covers the period when many of the supplies for the Rodd Hill forts were almost certainly ordered.

A third source was employed for further information about each individual item on the lists: the List of Changes in War Materiel and of Patterns of Military Stores... (the title varies) for the years 1880-1904.³ This, in many cases, gave a valuable description of the item.

Other useful sources include the Treatise on Military Carriages and Stores Connected with them (1902), the Treatise on Service Ordnance (1908) and the Handbook for the 6-Inch B.L. and B.L.C. Guns, Mountings, &c. (1904).⁴

This equipment list, therefore, is most accurate for the year 1904. It is moderately accurate for the period 1898-1908 and it is not too accurate for the period 1908-38 because we have every indication that much of the equipment left in the forts when the British handed them over in 1906 was still there years later. When one reaches the period for which we do have fragmentary equipment lists (1927-37), one is struck by the fact that much of the equipment listed is, in fact, obsolescent.⁵ Nonetheless, further work is required before any conclusions can be drawn about the state of the equipment at any period after 1904.

The organization of this chapter presented special problems. Four different methods have been employed to set out the information. In addition to the basic list, some topics (the shells, the cartridges, the gun, the carriage, the DRF, etc.) are treated in brief essays. A consolidated set of tables presents the information in tabular form (see below, Consolidated Equipment Tables). In cases where one

source or another provided a particularly long or important account of a feature, that account has been placed in an appendix.

Even at this, the task of condensing the information from some sources (notably the List of Changes) has proved to be almost impossible and, for further information, the reader is referred either to the original sources or to the bound research notes on which this chapter is based and which are at present in the possession of National Historic Parks and Sites Branch in Ottawa.

The Gun

The gun in use in both Upper and Lower Battery was an "Ordnance, B.L., 6-inch (Mark VI)," first approved for service in 1891.⁶ The Mark VI gun was virtually identical to the Mark IV gun, first produced in the same year, and, in many particulars, was similar to the Mark III, approved in 1882.⁷ Each Mark VI barrel weighed 5 tons and cost £1140.⁸

The best brief description of the Marks IV and VI guns is found in the Handbook (1904) and is quoted in its entirety below:

Ordnance, B.L. 6-inch, Marks IV and VI....

Mark IV. - This gun consists of a toughened steel "A" tube over which are shrunk the breech piece (prolonged at the rear for the reception of the screw), and "B" hoops. A jacket with trunnions is shrunk over the breech-piece, and a short hoop, "C," is shrunk over the "1 B" hoop in front of the trunnions.

A hood, "D," is attached by screws to the jacket to protect the breech fittings. The chamber is cylindrical, terminating in front

with a curved slope.

MARK VI. - This gun differs from Mark IV in the method of hooping the chase, which in guns of the latest manufacture is made in one piece. The fittings and sights are interchangeable for either mark of gun.

Breech Mechanism (Marks IV, VI, and II Drill Guns)....

The breech is closed by a screw having three portions of the thread removed longitudinally, each one-sixth of the circumference. The interior of the gun at the breech being prepared in a similar manner, admits of the screw, when the raised portions are placed opposite the smooth surfaces in the gun, being pushed home, and locked by the sixth of a turn.

The screw has hinged to it a cam-lever in two parts, by which it is locked and unlocked; the cam portion of this lever (when the breech-screw is locked) falls into a recess in the carrier ring, and so prevents any movement of the breech-screw during firing. In depressing the cam-lever after the breech-screw is unlocked, the cam, acting upon the surface of the carrier ring, partially withdraws the breech-screw together with the obturator. The lever, when in the locked position, is held by a clip at its lower end, to prevent it from flying up during recoil. A lengthening lever is supplied to give additional power when required.

Encircling the rear end of the

breech-screw and hinged to the hood is a carrier ring, which supports the screw when withdrawn.

On the outer face of the breech-screw is a stud, which, coming in contact with a projection on the carrier ring, forms a stop when the screw is unlocked.

The carrier ring is held to the gun during the withdrawal of the breech-screw by a "clip" pivoted within the left side of the ring, engaging with a recess in the hood. In cases where difficulty is found in closing the breech, owing to excessive wear of the recess in the hood for the reception of the carrier ring retaining clip, the hood will be repaired by the insertion of a hard steel piece secured by two fixing screws.

A stop-bolt in the right side of the carrier ring prevents the breech-screw being disengaged from the carrier when withdrawn; at the same time the clip is disengaged from the recess in the hood by means of a spring, which forces its opposite end into a recess in the breech-screw, thus securing the latter in the carrier ring. When in this position, the whole can be swung clear of the breech opening to admit of loading.

A steel safety block is now fitted to the hood and breech face, so as to prevent the indicator on the lock guide bolt being in the "UP" position when the lock is raised after the breech is closed.

The carrier ring was formerly retained in the loading position by a spring "latch" now

removed and replaced by a preserving block.

In closing the breech, the upper arm of the clip is elevated by coming into contact with an inclined plane in the hood, and the clip being pivoted, is consequently released from the recess in the screw, leaving it free to be pushed home.

In the case of Mark II drill guns, the fittings are interchangeable with those of Marks IV and VI guns, except the carrier ring with hinge bolt, one flat and two spiral springs; breech screw with cam lever and two spiral springs; axial vent with spiral spring nut and washer.

Obturation (Marks IV, V, and II Drill Guns)...

The system of obturation consists of a circular pad, with front and rear protecting discs of tin fitting the mouth of the chamber, placed between the head of the axial vent and the breech-screw.

The pad being slightly elastic, expands radially when compressed by the action of the gas generated by the fired charge, thus completing obturation.

Thin discs of steel are used to adjust the required thickness of the obturating pad as follows:-

Should the obturator be found not to fit the cone seating in the gun correctly (and this can be ascertained by covering the seating lightly with grease and seeing that the obturator is covered all over, after the breech has been closed and opened again), adjusting

discs should be added one by one until the breech closes a little tightly through the obturator being pressed forward into the seating. To admit of the adjusting discs being placed behind the obturator, a clearance of about one-tenth of an inch is provided in the breech fittings to allow of the vent being moved forward, but the whole of this clearance would seldom be required.

Note. - When firing E.X.E., or other brown powders, a wet sponge cloth should be placed over the mushroom head of the axial vent as soon as the breech is opened, after firing a round in order to minimise the risk of premature explosions which might be caused by the heated residue on the head coming in contact with the bare prisms of the cartridge when the breech is closed.

Firing Mechanisms (Marks IV, VI, and II drill)....

The mechanism is so arranged as to prevent the gun being fired before the breech-screw is in its locked position.

It consists of a steel vent passing through the centre of the breech-screw, having secured to its outer end a box in which the percussion lock slides, the latter being pushed into a position over the vent, when the breech is being closed, by a guide bolt gearing with a cam-groove in the carrier ring, and by the action of an inclined spring guide on the carrier ring. Should there be a projecting tube in the vent, the spring of the guide

yields, to prevent the shearing of the tube.

Particular attention is called to the instructions, as to the insertion of the tube, given here. The tube is never, under any pretext whatever, to be inserted before the breech is closed.

The locks for these guns are as follows:-

1. Ordnance, B.L., lock, percussion-
 - (a) "H") for 6-inch IV and
 - (b) "K") VI guns.
2. Ordnance, B.L., 6-inch, Marks III, IV, VI, and II drill-

Lock percussion. - For these guns when used for drill and practice purposes in the land service.

(1a.) The "H" lock consists of a frame which is fitted with a striker, cocking lever, trigger, and spring guide bolt. The striker is actuated by a volute spring, and is worked by means of the cocking lever and trigger; the trigger is provided with a loop for the attachment of a lanyard, and is so arranged that the first movement to the rear engages the cocking lever and forces the striker into the cocking position; on continuing the movement to the rear the trigger is disengaged from the cocking lever, when the striker is free to detonate the tube. The trigger is automatically returned to its original position by means of a spring, so soon as the pull on the lanyard is released. One end of the cross-handle of the guide bolt has a brass ferrule, on which the wood U P and an arrow are engaged, thus - U↑P, and before firing it

should always be seen that this arm is uppermost without opening the breech. The guide bolt can be withdrawn from the cam-groove by turning the cross-handle, to allow the lock to be drawn back for inserting a tube in the vent, or changing it in the case of a miss-fire. When the breech is open, the lock is retained in the grooves of the slide box by a spring stop-pin.

(1b.) The "K" lock (converted from the old percussion lock for these guns, and described hereafter) is generally similar to the "H" lock, but the case for the volute spring of the striker is screwed on to the frame, instead of being solid as in the new "H" lock; and a few other manufacturing details.

(2.) The percussion lock for use with the land service, Marks IV, VI, and II drill guns, for drill and practice, is that formally employed for all services with these guns. The lock consists of a frame containing a hammer actuated by the main spring. The hammer is retained in its elevated position by a trigger.

The lock, which acts automatically with the closing of the breech, contains a striker for transmitting the blow from the hammer to the tube. A lanyard bolt having one side bevelled, corresponding with the end of the trigger, is fitted to the slide box. When the lanyard bolt is pulled, the trigger is pressed, thereby releasing the hammer. The cam-groove in the carrier ring of the gun retains the lock in such a position that the striker is not immediately over the tube till the breech-screw

is locked. Without opening the breech, the guide bolt, which is furnished with two springs, can be withdrawn from the cam-groove by turning the cross-handle, to allow the lock to be drawn back for inserting a tube in the vent, or changing it in case of a miss-fire. The instructions in the description of the "H" lock, regarding the "UP position" of the guide bolt and cross-handle, equally applies to this lock. When the breech is open, the lock is retained in the grooves of the slide box by a spring stop-pin.

The locks are suitable for electric firing; "Tube, v.-s., electric, P," is used, the wires being led out from the end, downwards, the lock supporting the head of the tube.

When Marks IV and VI guns are mounted on V.C.P. and barbette carriages, not provided with a sighting platform (which affords a straight pull of the firing lanyard to the rear), a lanyard guide is pivoted to the cam-lever, and is fitted with a sheave placed so as to direct the lanyard to the right side of the gun, and by this means ensure a straight pull in the line with the axis of the trigger or lanyard bolt, according to the pattern of lock, when firing.⁹

Establishing a parts list for the gun, breech mechanism and firing mechanism is complicated by two factors. In the first place, some of the equipment was issued with the gun and appears in the equipment regulations simply as "Ordnance, B.L. 6-inch." Secondly, the parts list altered slightly from year to year as minor alterations were made in

the Mark VI gun. The list which follows represents the complete authorization for the year 1904. The complete nomenclature is given for each part in most cases, followed by the abbreviated form by which each part is listed in the Consolidated Equipment Tables: Gun Equipment (where applicable). For a listing of the numbers of each part authorized and the proportion authorized as spare, see the Consolidated Equipment Tables: Gun Emplacement.

"Ordnance, B.L., 6-inch":

Bolts, stop, steel for breech screw
 Boxes, slide, steel...
 Clamps, tangent sight, automatic, B, bronze
 Clips, cam lever, steel...
 Contacts, electric, safety arrangement
 Discs, pad, obturating, adjusting, steel (Discs, 1)
 Discs, pad, obturating, protecting, rear, tin (Discs, 2)
 Discs, pad, obturating, protecting, front, tin (Discs, 3)
 Levers, cam, with hinge bolt and keep pin...(levers, 1)
 Levers, lengthening cam lever, steel...(levers, 2)
 Locks, percussion H (or percussion K)...
 Obturators, asbestos, canvas covered
 Pins, keep, hinge bolt, cam lever, steel, bulb-head, length 3(?) inches (Pins, 1)
 Pins, keep, hinge bolt, carrier ring, steel, bulb head, length 3.5 inches (Pins, 2)
 Pins, keep, keys, box slide, steel, length 1.425 inches (Pins, 3)
 Rings, carrier, steel, with hinge bolt and keep pin...
 Screws, breech, steel, with Mk II* or Mk III cam lever with hinge bolt and keep pin...
 Sights, B.L., fore, left (sights, 1)
 Sights, B.L., fore, right (sights, 2)
 Sights, B.L., tangent, left (sights, 3)

Sights, B.L., tangent, right (sights, 4)
 Sockets, foresight, A, bronze
 Springs, catch, cam lever, down, steel, spiral (springs, 1)
 Springs, clip, cam lever (springs, 2)
 Springs, clip, carrier ring, flat (springs, 3)
 Springs, cocking lever, locks, percussion, G, H, J, and K,
 spiral, steel (springs, 4)
 Springs, guide bolt, lock, percussion, ejecting, steel
 spiral (springs, 5).
 Springs, lock, percussion, twisting, steel, spiral (springs,
 6)
 Springs, guide bolt, lock, percussion H, ejecting, steel,
 spiral (springs, 7)
 Springs, guide for lock, steel, spiral (springs, 8)
 Springs, stop, pin, steel, spiral (springs, 9)
 Springs, vent axial, steel, spiral (springs 10)
 Strikers, lock, percussion, D, steel, with spindle and keep
 pin (strikers, 1)
 Strikers, lock, percussion, G, H, J, and K, steel
 (Strikers, 2)
 Triggers, lock, percussion, H and K, steel, with axis pin
 Vents, axial, steel, with spiral spring, nut and washer.¹⁰
 (For a complete listing of List of Changes paragraphs
 dealing with the Mark VI gun to 1904, see Appendix B.

The Carriage

The proper nomenclature for the hydro-pneumatic carriages on which the 6-inch guns were mounted is "Carriage, garrison, disappearing, B.L., 6-inch. (Mark IV)."¹¹ This, introduced in 1889, was the fifth and last mark of the 6-inch HP carriage to be produced. Of its four predecessors, one, the Mark I, had been, in effect, a prototype. It differed from all the others in several important respects, most noticeably

in having a central pivot. The other four marks (II, II*, III and IV) were all quite similar, most parts being interchangeable among them.¹²

The carriage was the single most complicated piece of machinery in use at the fort. It was also the most expensive. The basic carriage body and roller ring (on which it traversed) cost £2070 in 1898.¹³ This did not include a long list of fittings for the carriage which had to be requested separately and which added to the cost.¹⁴

No concise contemporary description of the Mark IV carriage is immediately available, as all official publications were concerned chiefly with differentiating the Mark IV from its predecessors. The following description of the Mark II is possibly the best short description of the 6-inch HP carriage. The initial entry for the Mark IV in the List of Changes, also quoted below, states how the Mark IV differed from the Mark II:

Carriage, garrison, disappearing, B.L., 6-inch.
(Mark II) Hydro-pneumatic for Mark IV gun. ...

The carriage is constructed to raise the gun by means of compressed air, so as to admit its being fired at angles from 20 degrees elevation to 5 degrees depression, and to store the force of the recoil as the gun descends under cover for loading.

I. It consists of the following parts:-

1. Elevator with crosshead
2. Lower carriage with live roller ring.
3. Hydro-pneumatic cylinder and ram.
4. Elevating and traversing gear.
5. Cut-off gear.
6. Overhead shield.
7. Racer and training rack.

The elevator...consists of two steel

brackets connected by steel transoms. It is pivoted to the lower carriage...and raised to the firing position by the ram of the hydro-pneumatic cylinder...to which it is connected by a steel crosshead....

The lower carriage...is made up of two steel plate girders, which are connected by steel-plate transoms at the front and rear, and fitted with bracket...to which the elevator is pivoted. The carriage revolves on a live roller ring...containing flanged steel rollers (bushed with gunmetal), which run on the roller path or racer, secured by holding-down bolts and plates to the concrete. The lower carriage rests on the rollers, upper roller paths being rivetted to its under surface.

Two sighting ladders...and steps...are provided for use in sighting the gun; the steps are fitted with spiral springs, by which they are raised to a vertical position to clear the gun. The step is secured in the vertical position by an automatic gear, which consists of a shaft with a combination of levers, a pawl, and counterweight, when the step is up the pawl passes through a slot cut in the step and is forced down by the counterweight.

Two rough sights are fixed to the shield, and mirrors are attached to the top and bottom of one elevator bracket for giving direction.

A pointer for use with the traversing arc is fitted to the front transom of the carriage, and so arranged that the edge of the pointer will be at a radius of 5 feet 10 inches from the centre of the mounting.

The recoil cylinder is of forged steel, and is turned to receive the trunnion band, which is fixed in position by a shoulder on the cylinder and four set screws. It has an inner chamber for the recoil ram, and eleven smaller chambers for the necessary supply of liquid (12-1/2 gallons of the fluid...) and compressed air. The inner chamber is connected to the air chambers at the lower end of the cylinder by raising and recoil valves; the air chambers are connected at the top by small holes to equalize the air pressure.

The cylinder is filled with (1) a filling cock, by which liquid and air are pumped in (2) a level cock for the purpose of ascertaining when the liquid is at its proper height, (3) a plug, which opens into the inner chamber for discharging the air that may accumulate at the top; and the ordinary U leather ring, stuffing box, and packing gland to prevent leakage at the ram.

A lowering pump...is fitted for pumping the gun down into the loading position, in the event of short recoil, or if it is required to lower the gun to the loading position without firing; the pump draws the liquid from the inner chamber, and delivers it through non-return valves into the air chambers, thus allowing the gun to descend by its own weight.

The action of the cylinder is the same as the Mark I...but the working pressures are 1250 lb. per square inch with the gun down and 750 lb. with the gun up.

The elevating gear is fitted on both sides

of the carriage, and is worked by means of a handwheel...on the right side of the mounting, it is similar to the Mark I...differing only in the elevating rod, and the radius of the arc in consequence of the differences in the lengths of the gun.

The traversing gear is fitted at the front of the carriage and is actuated by two handwheels...which transmit motion through bevel pinions and wheels, and vertical shafts to pinions which engage with a rack fixed to the roller path.

The cut-off gear is provided to close the raising valve when the gun is in firing position, thus preventing strain on the head of the cylinder, and also ensuring the gun shall not raise again after firing from the valve being inadvertently left open. The valve is opened and closed by a toothed pinion, with a screwed thread on its shank. The pinion is turned by a rack, and as it turns, it withdraws or presses home the valve spindle. The rack is worked by a lever through a connecting rod. This lever is worked by either the hand lever or the cut-off chain. The chain has two branches, one attached to the head of the ram, the other to the elevator transom, which arrangement prevents the chain from sagging or becoming hitched when the gun is down. It also has a right and left-hand screw, with an adjusting nut, for adjusting the length of the chain. When the cut-off is automatic, the raising of the ram tightens the chain which pulls the lever and closes the valve. The

chain, &c, must be adjusted so that the valve is quite closed when the gun is up.

The overhead shield...is of steel, it is supported on eight steel pillars resting in sockets on the lower carriage, and it has openings in the top to admit the gun passing it when being raised....¹⁵

Carriage, garrison, disappearing, B.L., 6-inch, (Mark IV)....

It is similar in general design to the Mark II...differing in only the following particulars:-

1. The recoil cylinder, which is of a larger diameter, and has ten air chambers, the position of the trunnions, and the quantity of the liquid required, which is 20 gallons.

2. The raising valve is situated at the top of the under surface of the cylinder, instead of at the bottom.

3. The hand lever of the raising valve is on the right instead of the left side of the mounting.

4. The retaining clips for holding the elevator down are attached to the buffers, instead of at the top of the lower carriage, they are of a different pattern, and are provided with a padlock.

5. The holding down clips are of a different pattern. There are two in front on Mark II, which on Mark IV are replaced by one, and the bracket of the traversing pointer is consequently of a different pattern.

6. the pattern of the sighting steps is

somewhat different.

Generally, the parts of the carriages of this description, bearing different distinguishing numerals, are non-interchangable, though similar. It is necessary, therefore, in demanding any spare parts or making any report, to specify the mark, and also to quote the Register no. which is stamped on the mounting or racer.

	tons	cwt. ¹⁶
Weight	13	3

As might be expected, the parts list for the carriage is quite a long one. As arranged below, the parts are listed alphabetically. There are six sub-heads. In other respects, the arrangement is the same as for the gun parts listed above. For further information on the distribution of parts and spares, see Consolidated Equipment Tables:

Carriage Equipment.

Carriage, Body:

Carriage, body, without fittings

Arcs, indicator, lever, cross shaft, raising valve, steel, with nuts

Arcs, traversing, No. 15.

Bearings, shaft, cross, lowering pump, 1st motion...

(bearings, 1)

Bearings, shaft, cross, lowering pump, 2nd motion...

(bearings, 2)

Bearings, shaft, cross, raising valve...(bearings, 3)

Bearings, shaft, elevating, 1st motion...(bearings, 4)

Brackets, carrying, traversing gear...(brackets, 1)

Brackets, elevator, joint pin, left, steel(brackets, 2)

Brackets, elevator, joint pin, right, steel(brackets, 3)

Bracket, shield pillars...(brackets, 4)
 Brackets, shield, tangent sights...(brackets, 5)
 Brackets, trunnion, recoil cylinder...(brackets, 6)
 Buffer stops, elevator...
 Cable, electric, unarmoured, D 13
 Connections, pressure gauge, for connecting gauges to
 recoil cylinder
 Cotters, shield pillars, with eye, steel (cotters, 1)
 Cotters, shield pillars, plain, steel (cotters, 2)
 Cylinder, recoil, steel
 Cylinder, recoil, bracket, guide, plunger, pump, lowering...
 (cylinder, recoil, bracket, 1)
 Cylinder, recoil, bracket, guide, rack, raising valve...
 (cylinder, recoil, bracket, 2)
 Cylinder, recoil, bracket, raising valve...(cylinder,
 recoil, bracket, 3)
 Cylinder, recoil, caps, recoil valve, G.M.
 Cylinder, recoil, glands...
 Cylinder, recoil, packing, hydraulic, 7/8 inch square,
 length of 30 inches
 Cylinder, recoil, plugs, air chamber, for valves,
 draw off, steel (cylinder, recoil, plugs, 1)
 Cylinder, recoil, plugs, air chamber, ordinary...
 (cylinder, recoil, plugs, 2)
 Cylinder, recoil, plugs, air chamber, pump, connection...
 (cylinder, recoil, plugs, 3)
 Cylinder, recoil, ram, G.M., with nut and screw
 Cylinder, recoil, rings, filling in, gland, steel
 cylinder. recoil, rings, 1)
 Cylinder, recoil, rings, gland, bottom, P.B. (cylinder,
 recoil, rings, 2)
 Cylinder, recoil, rings, gland, top, P.B. (cylinder,
 recoil, rings, 3)
 Cylinder, recoil, springs, disc, no. 21

Cylinder, recoil, tubes, draw off, G.M.
 Cylinder, recoil, valves, draw off, G.M. (cylinder,
 recoil, valves, 1)
 Cylinder, recoil, valves, filling, G.M. (cylinder, recoil,
 valves, 2)
 Cylinder, recoil, valves, recoil, filling (cylinder,
 recoil valves, 3)
 Cylinder, recoil, valves, stop, pump, lowering, delivery,
 G.M. (cylinder, recoil, valves, 4)
 Cylinder, recoil, valves, stop, pump, lowering, suction,
 G.M. (cylinder, recoil, valves, 5)
 Cylinder, recoil, valves, water level (cylinder, recoil
 valves, 6)
 Cylinder, recoil, washers, packing, leather (cylinder,
 recoil, washers, 1)
 Cylinder, recoil, washers, packing, lead, set of 16
 (cylinder recoil, washers, 2)
 Elevators, without fittings
 Elevator, capsquares, left, steel
 Elevators, capsquares, right, steel
 Elevators, keys, capsquare, no. 74, iron with chain
 Elevators, pins, joint, steel, with collars and keys
 Gauges, Pressure, No. 2
 Gauges, pressure, No. 3.
 Guards, gun muzzle, on shield (guards, 1)
 Guards, protecting gun layer, arm, steel (guards, 2)
 Guards, protecting gun layer, leg, steel (guards, 3)
 Guides, arc, elevating, left (guides, 1)
 Guides, arc, elevating, right (guides, 2)
 Hooks, stowing, lever, pump, lowering
 Keys, driving, cross shaft, steel (set of 4)
 Ladders, sighting, front
 Ladders, sighting, rear, left
 Ladders, sighting, rear, left...

Lanyard, bolts, steel...

Pedestal, supporting sight gear, steel...

Pillars, shield (eight)

Pistons, spur, 1st motion shaft, G.M., 11 teeth (pistons 1)

Pistons, spur, 2 motion, steel, 10 teeth (pistons, 2)

Plates, arrow, elevator (plates, 1)

Plates, arrow, elevate, left (plates, 2)

Plates, arrow, elevate, right...(plates, 3)

Plates, arrow, depress, left...(plates, 4)

Plates, arrow, depress, right...(plates, 5)

Plates, arrow, trail, left...(plates, 6)

Plates, arrow, trail, right...(plates, 7)

Plates, clip, front...(plates, 8)

Plates, clip, rear...(plates, 9)

Plates, cover, shield, No. I...(plates 10)

Plates, cover, shield, No II...(plates, 11)

Plates, cover, shield, No. III...(plates, 12)

Plates, cover, shield, No. IV...(plates, 13)

Plates, cover, shield, No. V...(plates, 14)

Plates, cover, shield, No. VI...(plates, 15)

Plates, cover, shield, No. VII...(plates, 16)

Plates, foot, left, inner front...(plates, 17)

Plates, foot, left, inner, rear...(plates, 18)

Plates, foot, left, outer, front...(plates, 19)

Plates, foot, left, outer, rear...(plates, 20)

Plates, foot, right, inner...(plates, 21)

Plates, foot, right, outer, rear...(plates, 22)

Plates, foot, right, outer front...(plates 23)

Plates, foot, manhole, steel...(plates, 24)

Plates, inscription...(plates, 25)

Plates, instruction, lowering pump, G.M....(plates, 26)

Plates, instruction, raising valve, G.M....(plates, 27)

Plates, instruction, recoil cylinder, G.M....(plates, 28)

Plates, manhole, shield, steel. (plates, 29)

Plates, arrow, gun up, G.M....(plates, 30)

Pointers, arc traversing, No. 4, steel, with G.M. bracket...

Pointers, indicating gun up, steel, with G.M. bracket and screws

Racers, steel, with traversing rack bolts and screws

Roller ring

Roller ring, axles, steel...

Roller ring, rollers, carriage, No. 7.

Rollers, guide, firing, lanyard, G.M. (also cocking)

Shield, overhead, steel...

Socket, shield, pillars

Spindles, rollers guide, firing lanyards, steel...

Springs, disc, No. 13, steel

Standard, guide, roller, firing lanyard, left...
(standard, 1)

Standard, guide, roller, firing lanyard, right...
(standard, 2)

Stays, shield pillars...

Steps, sighting, automatic, brackets, pawlshaft, long...
(steps, sighting, brackets, 1)

Steps, sighting, automatic, brackets, pawlshaft, short...
(steps, sighting, brackets, 2)

Steps, sighting, automatic, brackets, shaft, left...
(steps, sighting, brackets, 3)

Steps, sighting, automatic, brackets, shaft, right...
(steps, sighting, brackets, 4)

Steps, sighting, automatic, brackets, supporting, left...
(steps, sighting, brackets, 5)

Steps, sighting, automatic, brackets, supporting, right...
(steps, sighting, brackets, 6)

Steps, sighting, automatic, collars, clutch, right...
(steps, sighting, collars, 1)

Steps, sighting, automatic, collars, clutch, right...
(steps, sighting, collars, 2)

Steps, sighting, automatic, counterweight, C.I. with
steel lever

Steps, sighting, automatic, hooks, spring, steel

Steps, sighting, automatic, levers, pawl shaft, ...
(steps, sighting, levers, 1)

Steps, sighting, automatic, levers, large...
(steps, sighting, levers, 2)

Steps, sighting, automatic, levers, small...
(steps, sighting, levers, 3)

Steps, sighting, automatic, links, connecting ladder rounds,
left...(steps, sighting, links, 1)

Steps, sighting, automatic, links, connecting ladder
rounds, right... (steps, sighting, links, 2)

Steps, sighting, automatic, pads, buffer, india-rubber...

Steps, sighting, automatic, pawls, left...(steps, sighting,
pawls, 1)

Steps, sighting, automatic, pawls, right...(steps,
sighting, pawls, 2)

Steps, sighting, automatic, pieces, backing, wood

Steps, sighting, automatic, rods, connecting, levers...

Steps, sighting, automatic, rounds, ladder, long, steel
(steps, sighting, rounds, 1)

Steps sighting, automatic, rounds, ladder, short, steel
(steps, sighting, rounds, 2)

Steps, sighting, automatic, shafts, with collars,
feather and keys (steps, sighting, shafts, 1)

Steps, sighting, automatic, shafts, pawl, steel, with
collars, set screws, and keys (steps, sighting,
shafts, 2)

Shafts, sighting, automatic, springs, spiral, steel

Steps, sighting, automatic, steps, left, steel
(steps, sighting, steps, 1)

Steps, sighting, automatic, steps, right, steel (steps,
sighting, steps, 2)

Gear, Elevating:

Arcs, left, steel
 Arcs, right, steel
 Band, friction, brake drum...
 Cone, friction, spur wheel...
 Drum, break, iron
 Pawls, break, steel
 Pins, elevating, arc, right...(pins, 1)
 Pins, elevating, arc, left...(pins, 2)
 Pointer, elevating, arc, steel
 Rods, elevating, left
 Rods, elevating, right
 Shafts, 1st motion...
 Shafts, 2nd motion...
 Springs, disc, No. 15, steel (break drum)
 Springs, disc, No. 17, steel (cone spur wheel)
 Wheels, hand, iron
 Wheels, spur, G.M., 56 teeth

Gear, Elevation, Indicator:

Brackets, yard scale, plate...(brackets, 1)
 Brackets, yard scale, pointer...(brackets, 2)
 Plate, yard scale...
 Pointer, yard scale plate, steel...

Gear, Pump, Lowering:

Handles, socket, steel with clasp and pin
 Levers, cross-shaft, link, connecting, 1st motion
 shaft...(levers, 1)
 Levers, cross-shaft, link, connecting, 2nd motion
 shaft...(levers, 2)
 Levers, cross-shaft, plunger (levers, 3)
 Links, connecting levers, 1st and 2nd motion shafts,

steel

Pipes, suction, copper...
 Pipes, delivery, copper...
 Pump body, G.M.
 Pump, boxes, stuffing, G.M.
 Pump, glands, G.M.
 Pump, packing, hydraulic, 3/4 inch square, length of 4 feet
 Pump, plugs, guide valves, steel
 Pump, plugs, stopping holes
 Pump, rings, packing, gland, G.M.
 Pump, rods, guide, plunger, G.M.
 Pump, rods, plunger, G.M.
 Pump, springs, valve, delivery, P.B. (pump, springs, 1)
 Pump, springs, valve, suction, P.B. (pump, springs, 2)
 Pump, valve, delivery, G.M.
 Pump, valve, suction, G.M.
 Pump, washers, packing, pump, lead, set of 5 (washers, 1)
 Pump, washers, packing, pipes, delivery and suction, lead,
 set of 4 (washers, 2)
 Shafts, cross, 1st motion, steel, with keys (shafts, 1)
 Shafts, cross, 2 motion, steel, with keys (shafts, 2)

Gear, Raising, Valve:

Boxes, stuffing, P.B.
 Glands, G.M.
 Levers, link, connecting, left, iron...(levers, 1)
 Levers, link, connecting, right, iron...(levers, 2)
 Levers, hand, cross shaft, iron (levers, 3)
 Links, connecting, iron, with pin, collar and key
 Packing, for gland, length of 15 inches
 Plates, cover, iron, with screws
 Rack, iron, with pin, collar and key
 Rings, packing, G.M.
 Rods, cut-off

Shafts, cross, iron with collar and keys
 Spindles, valve, G.M. with nut and split key

Gear, sighting:

Arm, supporting, telescope carrier, M.B. with fixing screw
 Brackets, hinge, stud, G.M....
 Carrier, telescope, G.M....
 Drum, yard scale, G.M....
 Flap, hinge, telescope carrier, G.M....
 Lever, sight frame, steel with M.B. brackets
 Link, connecting flap, steel...
 Pillars, foresight, steel...
 Pillars, tangent sight, steel
 Pillars, supporting telescope carrier, steel
 Posts, hand, rough sights
 Rod, connecting sight frame, steel...
 Sights, rough, on shield, front, steel...(sights, 1)
 Sights, rough, on shield, rear, steel...(sights, 2)
 Slides, adjusting, G.M...
 Stud, hinge, sight frame, steel...

Gear, Traversing:

Pistons, bevel, 1st motion, steel, 12 teeth, with key
 Pistons, spur, 2 motion, steel, 12 teeth, with nut and key
 Wheels, bevel, 2 motion shaft, steel, 36 teeth
 Wheels, hand, iron

Platform, Landing, and Rear Sighting Step:

Brackets, supporting wood platform, landing, inner, left...
 (brackets, 1)
 Brackets, supporting wood platform, landing, inner, right...
 (brackets, 2)
 Brackets, supporting wood platform, outer...(brackets, 3)
 Brackets, supporting, step, sighting, left...(brackets, 4)

Brackets, supporting, step, sighting, right...(brackets, 5)
 Ladders, platform, landing, left (ladders, 1)
 Ladders, platform, landing, right (ladders, 2)
 Levers, step, sighting, with key
 Plates, loop, securing step, sighting, with links
 Platform, left, wood, in two pieces.
 Platform, right, wood, in two pieces.
 Steps, sighting, steel, with ladder, handrail, and
 securing bolt
 Rail, hand, with bolt
 Shafts, steps, sighting, with collar, feathers, and key
 Stays, ladder, platform, landing, left...(stays 1)
 Stays, ladder, platform, landing, right...(stays, 2)
 Stays, platform, landing, inside, left...(stays, 3)
 Stays, platform, landing, inside, right...(stays, 4)
 Stays, platform landing, outside, left...(stays, 5)
 Stays, platform, landing, outside, right...(stays, 6)
 Stays, step, intermediate...(stays, 7)
 Steps, intermediate, in two pieces
 Steps, sighting.¹⁷

For a complete inventory of List of Changes paragraphs dealing with the Mark IV carriage (to 1904), see Appendix C.

Cartridges

In 1904, the following cartridges were authorized for use with the 6-inch Mark VI gun:

- 12 lb. E.X.E. (gunpowder)
- 16 lb. 12 oz. cordite
- 14 lb. 12 oz. cordite
- 10 lb. cordite (saluting, etc.)¹⁸

Of these, the first mark of the 14 lb. 12 oz. cordite had been introduced in 1894;¹⁹ the first mark of the 16 lb. 12

oz. cordite in 1902;²⁰ and the first mark of the 12 lb. E.X.E. in 1889.²¹ The first two were packed in metal lined cases, the third in either metal lined cases or in zinc cylinders.²²

The first actual list of cartridges on charge in the western armament district of the Esquimalt Fortress (which included Rodd Hill, Belmont, Duntze and Black Rock) dates from 1935. This states that 947 16 lb. 12 oz. Mark I cordite cartridges and 437 14 lb. 12 oz. Mark II cordite cartridges were on charge. Although it is not explicitly stated, it is clear that all must have been at Rodd Hill.²³

As both types of cartridge listed in the 1935 inventory were first introduced into service in the 1899-1902 period,²⁴ and as we know from other sources that the Canadian artillery held on to its imperial ammunition for a surprisingly long time after inheriting it in 1906,²⁵ it seems reasonable to suppose that the cartridges in question dated from, at the latest, 1906.

This is not to say, however, that these were the only types of cartridge in use at Rodd Hill. It is impossible to make any definite statements about the imperial period. But it seems likely that cordite cartridges were always the mainstay of the fort's cartridge supply and that the 14 lb. 12 oz. cartridge is the one most likely to have been present in the work from the beginning.

A description of the two cordite cartridges and the one gunpowder cartridge is to be found in the List of Changes, and is quoted below:

Cartridge, B.L., 6-inch, 14 lb. 12 oz. Cordite.
(Mark I.)...

It is made of No. 2 class silk cloth...

The charge consists of 14 lb. 12 oz. of cordite, size 20/14, the neck and centre of the body consisting of 9 lb. 4 oz. of full strands,

while the projecting portion of the body is made up of lengths cut to 4.5 inches, and of the requisite weight to make up the total charge. The whole is secured in four places with silk twist.

Dimensions	in.
Length of neck	9.5
Diameter of neck	4.5
Length of base	4.6
Diameter of base (not to exceed)	7.75
Length over all (not to exceed)	14.6

Packing

The cartridges are packed, five in a metal lined case, viz.:-

Four base downwards on the bottom and one base downward, in the centre, resting on the projecting portions of the other four, paper cuttings being tightly packed into the vacant spaces, including that in the centre of the four cartridges on the bottom.²⁶

Cartridge, B.L., 6-inch, 16 lb. 12 oz. cordite, M.D. size 16. (Mark I)...

The empty cartridge is made of No. 2 class silk cloth, cylindrical in shape, and provided with .65-inch silk braid hoops.

The charge is of M.D. cordite, and has an angular recess formed at one end for a primer of 2 oz. of R.F.G. or new blank F.F. powder, contained in a pocket formed by two discs of shalloon, and stitched across the centre so as to form two compartments.

Six hollow, cylindrical felt pads are attached to the primed end of the cartridge.

Dimensions	inches
Length over all (not to exceed)	17.5
Diameter (not to exceed)	5.75
Packing	
Package	Number of cartridges
case, powder, M.L.,	Six (with a band of
whole.	1.5-inch braid round
	last cartridge packed
	to facilitate
	removal.) ²⁷

Cartridge, B.L. 6-inch, 12 lb. E.X.E. (Mark I)...

The service cartridge is made of No. 3 class silk cloth in the usual manner for prismatic cartridges.

The charge is built up in six layers, five of 22 prisms each, and one of such convenient number, not less than 16, as will bring the total weight of powder up to 12 lb. Should the top layer contain less than 16 prisms, one or more will be taken from each complete layer to make up the requisite number.

Care must be taken in stitching on the top that the seam is on the edge of the cartridge and not on the top or side.

The cartridge is not primed with Prism. black powder...

Dimensions	In.		In.
Length, empty...	8.25	to	8.75
Length, filled...	5.9	yo	6.3
Diameter, empty...	11.5	to	12.0
Diameter, filled			
(not to exceed)...	7.9		²⁸

Shells

The 1904 Equipment Regulations are not very helpful in providing any information on the shells authorized for a work like Rodd Hill. They merely state that the proportion of armour piercing (AP) to common lyddite shell authorized for the 6-inch Mark VI gun was 60:40.²⁹

Fortunately, an ammunition list from 1902 has survived. This reveals that the following shells were on charge at Rodd Hill:

	Upper Battery	Lower Battery
Shrapnel	50	140
AP shell	230	540
Common Lyddite	200	400
Common C.S. pointed	60	42
NP Shot	10	18 ³⁰

While the proportion of AP to lyddite in this list is more like 46:54, it is clear that these two were the most important shells in use.

By 1935, the stock of 6-inch shells on charge had dwindled to:

6-inch, AP Mark III	698
6-inch common pointed, Mk. V	100 ³¹

The District Gunner at Rodd Hill in 1936 remembers these shells. He also remembers that, according to the records then existing, these shells had been taken on charge in 1903-05.³²

We thus have a very good idea as to the type of shell in use at Rodd Hill. There are only two difficulties. It is not entirely clear which mark of a specific type of shell was actually in use and we cannot determine exactly when the shells were taken on charge or when they were finally disposed of.

The following descriptions of the AP, lyddite and common shells are taken from the Handbook for the 6-inch gun (1904):

Shell, B.L., Q.F., or Q.F.C., Armour Piercing, 6-inch, Gun...

Mark II shell is of forged or cast steel without bands, with a pointed head, which is hardened for the penetration of armour plate, and is struck with a radius of two calibres. The total length of the shell is left to the manufacturer. The walls are .93 inch thick. The base is closed with a steel bush which is screwed in as tightly as possible and the joint is rivetted up: this bush is tapered to take a "Fuze, percussion, base, large, No. 11." The groove for the driving band is undercut and the driving band is of the gas check design.

The inside of the shell is lacquered, and to further prevent premature explosion when the gun is fired from the powder setting back in the shell, the bursting charge is contained in a dowlas bag...

Mark III shell differs from Mark II in having waved ribs in the groove for the driving band; with the waved ribs the band is less liable to turn or strip off.

Shell, B.L., Q.F., or Q.F.C., Common, 6-inch, Gun...

The iron shell, Mark III, is somewhat shorter than the earlier marks of common shell. It has a Vavasseur driving band 1.754 inch wide, pressed into a groove .67 inch from the base. It is made of iron and has two cannelures. The

base of the shell is bored and screwed 14 threads per inch left hand for a metal plug, and countersunk about .16 inch in depth so as to admit of a lead disc being hammered in over the head of the plug after the shell is filled. The shell is lacquered within and the charge is contained in a serge or dowlas bag...

Mark IX is the Mark III iron shell with the groove for driving band undercut to prevent the band stripping off.

The cast-steel shells chiefly differ in construction from the iron shell in being longer, and with thinner walls.

Marks IV and V differ from VI in the capacity for bursting charge and the base plug, which is not flanged.

Mark VI has a longer and stronger fuze hole socket than the iron shell, and the base plug is larger, screwed 9 threads per inch and has a flange; there is no lead disc. The shell is also filled from the base, and the charge is contained in a silk or dowlas bag.

Mark VI* is similar to Mark VI, but is fitted with the Vavasseur driving band with gas check.

Shell, B.L., Q.F., or Q.F.C., Common Lyddite, 6-inch, Gun...

Mark II shell is made of forged steel, with a solid base, and it is fitted at the nose with a gun-metal socket, which is tapped to G.S. gauge. It is varnished inside, and is fitted near the base with a gas check driving band, the groove for which is undercut.

The bursting charge of lyddite...has in

present filling a...4-1/4 oz. exploder of picric powder and a primer of 8 drams of R.F.G. [or F.G.] new blank powder, the exploder and primer are separately choked in a shalloon bag; and both are enclosed in a paper cylinder, the chokes being downward; this cylinder is waterproofed and closed at the top with an aluminium cap which is secured with shellac cement.

Mark III shell differs from Mark II in having thicker walls, and consequently a smaller bursting charge.

Mark IV has a groove for driving band with waved ribs as mentioned for the Mark III a.p. shell; in other respects, the shell is the same as Mark III.³³

The DRF

While there is no doubt that there were depression range finders at Rodd Hill, there is some doubt as to the numbers involved and the type (or types). The equipment regulations are not much help, as they merely state that the numbers of DRF to be provided for each work was "as authorized."³⁴ Needless to say, we do not possess the authorization.

There are four DRF pedestals associated with Upper and Lower Batteries: two in Lower, one in Upper and one in the Battery Command Post behind the Warrant Officer's Quarters. This does not, however, mean that the work had five DRFs. In fact, none of the available witnesses who were at the fort in the 1930s remembers there being more than one. One thinks that it was a Mark II, while another remembers it as being more or less permanently left on the pedestal in the Battery Command Post.³⁵

When one turns to the equipment returns appended to the inspection reports of the permanent force RCA in Esquimalt, the picture becomes even more murky. The first of these inspection reports which has survived dates from 1927, and states that the RCA had only three DRFs on charge for all of Victoria-Esquimalt.³⁶ The 1929 list, however, shows 7 DRFs charged out to the permanent force.³⁷ The 1931 list, in which the stores are divided up by armament district, lists the western armament district (Rodd Hill, Belmont, Duntze and Black Rock) as follows:

Rangefinders Depression-

Mk. I -A	2
Mk. I -D	1
Mk. II*	3

This same return also gives the total number of rangefinders in the possession of the permanent force in Victoria-Esquimalt as seven.³⁸

The 1927 figures are probably a mistake. It seems unlikely that the RCA would have only had three DRFs for all the Victoria-Esquimalt forts. Seven is also a rather small number for the purpose, but, as it is reported year after year, it is likely to be the true one. If five of these were distributed among the five works in the western armament district, it is logical to assume that, at most, two of them were available for Upper and Lower Rodd Hill.

It seems futile to include a technical description of the DRF in this paper for two reasons. In the first place, we do not know which mark of DRF is appropriate and, in the second, the fort actually possesses a DRF. An annotated list of List of Changes paragraphs dealing with the various marks of DRF (to 1904) is included in Appendix D.

The following list of spare and auxillary parts authorized for the DRF is taken from the Equipment Regulations:

Range-finder, depression, cover, instrument on base plate,
Mk I

Range-finder, depression, cover, base plate, Mark II

Range-finder, depression, hoods

Range-finder, depression, lamp

Range-finder, depression, nuts, round

Range-finder, depression, pins

Range-finder, depression, telescope, diaphragm.³⁹

The numbers of each of these items authorized depended on the numbers of DRFs on charge and there was some variation in the type of spare authorized, depending on the mark of DRF in use. It is thus impossible to give a comprehensive listing of the probable numbers of these features present at Rodd Hill. A listing of the authorization for 1 Mark II DRF is provided in Consolidated Equipment Tables: DRF Equipment (see below) as a general guide to give some idea of the numbers involved.

Stores

The following list covers all items which do not fall into any of the categories listed above. In each instance, the nomenclature of the item is given and, where necessary, the item is annotated. For a listing of the numbers of each item authorized, see Consolidated Equipment Table: Stores.

BAGS, SAND, COMMON

Canvas bag, 2 ft. 9 in. by 1 ft. 2 in.

Each cost 2-1/2d for MkI and 6d for Mk. II⁴⁰

BARROWS, MAGAZINE LAMPS

Wheeled barrow for carrying magazine lamps in Barrows,
magazine lamps, trays (q.v.)

Each cost £3..17..0⁴¹

BARROWS, MAGAZINE LAMPS, TRAYS

Wooden tray for carrying two magazine lamps. Three fitted

on each barrow.

Each cost 15/8.⁴²

BARS, CROW, 6 FOOT

Each weighed 47 lbs. and cost 4/6.⁴³

BATTERY AND KEY, TEST AND FIRING

Device used for the electrical firing of the gun.

Available in four marks costing between £6..0..10 and
£8..12..0.⁴⁴

BATTERY AND KEY, TEST AND FIRING, BOX

Teak box containing batteries for electrical firing of gun.⁴⁵

BATTERY AND KEY, TEST AND FIRING, SADDLE

Device for fixing box to gun carriage.⁴⁶

BATTERY, LECLANCHE, CELLS

In various marks and various sizes. Used for, among other
things, the electrical firing of the gun.⁴⁷

BEARERS, CARTRIDGE CYLINDER

Authorized for carrying cartridge cylinders. It is unlikely
that this item was used at Rodd Hill.⁴⁸

BITS, VENT, 23-INCH⁴⁹

BLOCK, DRIVING, FRICTION RING, STEEL⁵⁰

BOOTS, MAGAZINE, OVERALL PAIRS

For wear over ordinary boots by inspecting officers.

Each pair cost 17/-⁵¹

BOXES, GREASE, 3 LB.

Tin, half-round box

Each cost 1/3-1/2⁵²

BOXES, OBTURATING PADS AND DISCS

Wooden frame with iron bolt and metal fly nut for holding
obturating pads and discs when not in use.

Each cost 10/8.⁵³

BOXES, SPARE PARTS⁵⁴

BOXES, TUBE, GARRISON, LAND SERVICE

Tin box (6-1/4 in. by 3 3/4 in by 3 5/8 in) for carrying
tubes.⁵⁵

BRUSHES, FLUE

Wire handled brush, 5ft. 6in long with head 6 in. in diameter, for cleaning recoil cylinder.

Each cost $1/8$.⁵⁶

BRUSHES, PIASABA, BORE 6-INCH

For cleaning the bore of the gun.

Each cost £1.13.9.⁵⁷

BRUSHES, WATER, CARRIAGE

A swabbing brush

Each cost $1/7$.⁵⁸

BUCKETS, SPONGE

A wooden bucket.

Each cost $3/9$.⁵⁹

CANS, LUBRICATING, NO. 9

Steel, half-pint can, with lever valve and removable spout.

Each cost $1/9$.⁶⁰

CANS, OIL

Tin armourer's oil can, conical with screw nozzle and handle.

Each cost 4d.⁶¹

CANS, OIL, FEEDING

1 pint conical can with cap, handle and spout, for feeding the magazine lanterns.

Each cost 4 $3/4$ d.⁶²

CANVAS, PACKING, HESSIAN

For use with Piasaba brushes (q.v.)

Cost 3 $3/4$ d per yard.⁶³

CARTRIDGES, FILLED, B.L., 6-INCH, GUN:

12 LBS. E.X.E. (Cartridges, 1)

16 LBS. 12 OZ. CORDITE, M.D. (Cartridges, 2)

14 LB. 12 OZ. CORDITE. (Cartridges, 3)

see above, Cartridges.

CARTS, TRENCH

Two slat, man draught, cart.

Each cost £25..0..0.⁶⁴

CASES, CARTRIDGE, NO. 25

Leather Case (19-1/4 in. by 5-3/4 in.) for bringing up cartridges to guns.

Each cost £1..10..4.⁶⁵

CASES, LARGE CLINOMETER

Leather case for carrying Clinometer, large (q.v.).⁶⁶

CHALK, PREPARED, WHITE

Cost 6-1/2d per box.⁶⁷

CHESTS, TOOL, FILLED, NO. 11 E

A carriage smith's garrison tool chest.

Each cost £9..5..6 filled.⁶⁸

For contents, see Appendix E.

CLINOMETERS, LARGE

Instrument for giving quadrant elevation and measuring vertical angles.

Each cost £3..9..0.⁶⁹

COMPOSITION, PRIMING

Issued in 2 oz. glass bottles. Used for re-priming vent sealing tubes.

Cost 6-1/2d per 2 oz. bottle.⁷⁰

COTTON, OLD SHEETING

Rags. (see next note)

COTTON, WASTE, WHITE

For cleaning purposes.

Cost 19/6 per cwt.⁷¹

COVERS, BREECH, B.L.

Canvas cover for protecting breech.

Each cost, 17/3.⁷²

COVERS, CARRIAGE, B.L.

50 lb. waterproof canvas cover for protecting gun and parts of the carriage.

Each cost £4..4..4.⁷³

COVER, GEAR FIRING, ELECTRIC, NO. 2

Canvas cover for firing gear.

Each cost 7/7.⁷⁴

COVERS, MUZZLE, B.L., NO. 5

Canvas cap for the muzzle.

Each cost 9/6.⁷⁵

CYLINDERS, CARTRIDGE, NOS. 22, 30, 34 and 58

Zinc cartridge cylinders for carrying cartridges from the magazine to the gun. These were probably not used at Rodd Hill.⁷⁶

CYLINDER, CARTRIDGE, B.L.

Used for drill purposes. Probably none at Rodd Hill.⁷⁷

DRIVERS, GRUMMET

Wooden mallet for removing grummetts (q.v.).⁷⁸

DRIVERS, SCREW:

G.S. 24 IN. (Drivers, 1)

G.S. 12 IN. (Drivers, 2)

G.S. 4 IN. (Drivers, 3)⁷⁹

DRUG, GUN OR STORE

Wheeled carriage for moving gun barrel or other heavy objects. One would probably have not been at Rodd Hill at all times, but there would have been one on the site intermittently.

Each cost £34..5..6.⁸⁰

DUBBING

Cost 3d per lb.⁸¹

EXTRACTORS, DRILL SHELL, NO. 1

For extracting drill shell from breech.

Each cost 12/6.⁸²

EXTRACTORS, TUBE, P, STEEL

Cost 10/-.⁸³

EXTRACTORS, TUBE, P, SPECIAL, STEEL.⁸⁴

FILTERS, HYDRAULIC, JACK

Each cost 5/8.⁸⁵

FRAME, STORE, HYDRAULIC, JACK

Iron frame for maintaining hydraulic jacks under pressure.
Each cost £8..9..3,⁸⁶

FUZE:

FUZE, PERCUSSION, BASE, LARGE, NO. 11 (Fuzes, 1)
Fuze for armour piercing shells.⁸⁷

FUZE, PERCUSSION, DIRECT ACTION, IMPACT, NO. 13.
(Fuzes, 2)⁸⁸

FUZE, TIME AND PERCUSSION, MIDDLE, NO. 54⁸⁹ (Fuzes, 3)

FUZE, FOR INSTRUCTION, PERCUSSION, BASE (Fuzes, 4)⁹⁰

FUZE, PERCUSSION, D.A., IMPACT, DRILL. (Fuzes 5)⁹¹

For further information on Fuzes, see Appendix F.

GAUGES, STRIKER, PROTRUSION, NO. 3

Steel, for B.L. and B.L.C. gun locks.⁹²

GLYCERINE, COMMERCIAL

Cost £2..10..0 per cwt.⁹³

GREASE, LUBRICATING, FOR COOLER CLIMATES

For use on cogwheel teeth.

Cost £1..1..2 per cwt.⁹⁴

GRUMMETS, PROJECTILE, B.L.

1-1/2 inch tarred rope, fitted to shell to protect the
driving band..⁹⁵

GYNS TRIANGLE

Metal tripod with pulleys, etc, for lifting guns and other
heavy equipment. One may not have been located at Rodd Hill
on a full-time basis, but one certainly would have been
present intermittently.

Each cost £81..0..0 (Mark I) and £103..10..0 (Mark II)⁹⁶

HAMMERS, CLAW, 28 OZ.

Each cost 2/9.⁹⁷

HANDSPIKES, COMMON, 7 FT.

Wooden handspikes.

Each cost 6/4.⁹⁸

HOLDERS, SHELL, B.L.

For fuzing shell with base fuze.

Each cost £2..9..6.⁹⁹

IMPLEMENTS, FUZE, SHELL AND CARTRIDGE, KEY, BASE FUZE AND PLUG (implements, 1)

A steel bar (18 in. by 1 in. by 1/2 in. thick) for removing base fuzes and plugs.

Each cost £1..3..8.¹⁰⁰

IMPLEMENTS, FUZE, SHELL AND CARTRIDGE, KEYS, FUZE AND PLUG, G.S. (implements, 2)

Iron implement for removing fuzes and plugs.

Each cost 8/10.¹⁰¹

INDICATOR, RANGE

Wooden board with number plates for transmitting range information to the gunners.

Each cost £7..9..6.¹⁰²

INSTRUCTION, GENERAL, STORES FOR

See Repository stores.

JACKS, LIFTING, HYDRAULIC, G.S., 10 TONS

A general purpose hydraulic jack.

Each cost £23..2..6.¹⁰³

KNIVES, LAMP

For cleaning grease out of the sockets of the magazine lamps.¹⁰⁴

LAMP, ELECTRIC, TELESCOPE

4 volt lamp, allowing night use of the DRF.¹⁰⁵

LAMP, ELECTRIC, TELESCOPE, BOX, JUNCTION

Electrical leads for the lamp, electric, telescope (q.v.)¹⁰⁶

LAMP, ELECTRIC, TELESCOPE, LEAD¹⁰⁷

LAMP, ELECTRIC, TELESCOPE, PLUG

Ebonite plug.¹⁰⁸

LAMP, ELECTRIC, TELESCOPE, SWITCH

Switch and resistance coil.¹⁰⁹

LAMP, FIGHTING

Copper lamp (12 in. by 7-1/4 in. by 7-1/4 in.), glazed on three sides, burning a rape oil and paraffin mixture.

Each cost £1..6..6 (Mark I) or £1..7..3 (Mark II).¹¹⁰

LAMPS, MAGAZINE:

LAMPS, MAGAZINE, PARTITION¹¹¹

LAMPS, MAGAZINE, WALL¹¹²

For further information, see Appendix G.

LANTERN, BULLSEYE, SEIGE¹¹³

LANTERN, HAND, MAGAZINE

Copper, bullseye lantern (11-1/4 in. by 5 in. by 4-5/8 in.)

Each cost 9/6.¹¹⁴

LANYARDS, FRICTION, TUBE

For percussion firing of the gun. Each was a tarred rope (11 ft. 10 in.) with toggle and loop.

Each cost 6-1/2d.¹¹⁵

LEATHERS, CHAMOIS

For cleaning the DRF.

Each cost 1/2.¹¹⁶

LINEN, OLD

Rags. Old bed linen was commonly used.¹¹⁷

LUTING

For lubricating fuzes and fuze holes.

Came in 1 lb. cylinders. Cost. 5d per lb.¹¹⁸

MAGAZINE CLOTHING¹¹⁹

MALLET, TINMANS

Boxwood mallet with cylindrical head (5-1/4 in. by 2-3/4 in.) for removing grummets (q.v.).

Each cost 1/1.¹²⁰

MEASURES, GLASS

4-oz. graduated, glass measure.

Each cost 8d.¹²¹

MEASURES, HYDRAULIC BUFFER

1 gallon tin, graduated measure with cock.

Each cost 18/8.¹²²

METHYLATED SPIRITS¹²³

MINERAL JELLY, RED¹²⁴

OAKUM¹²⁵

OIL, INSTRUMENT¹²⁶

OIL, LUTING

Equal amounts of rape oil and lubricating oil with a specific gravity of 910.

Cost 1/5 per gallon.¹²⁷

OIL, OLIVE¹²⁸

OIL, MINERAL¹²⁹

OIL, PARAFFIN¹³⁰

OIL, RANGOON¹³¹

PAD, FRAME, STORE, HYDRAULIC JACK

Felt pads and iron plates for securing the jack in its frame.¹³²

PLANK, STACKING, PROJECTILE

For rolling projectiles (?)¹³³

PLUG:

PLUG, BASE, SHELL, LARGE, NO. 1 (plug, 1)¹³⁴

PLUG, FUZE HOLE, SPECIAL (plug, 2)¹³⁵

PLUG, FUZE HOLE, DRILL, G.S. (plug, 3)¹³⁶

For more information, see Appendix H.

POCKET, GUNLAYER'S

Leather case for holding rimmer and tube extractor.¹³⁷

POTASH¹³⁸

PUMP, AIR, DOUBLE¹³⁹

RAMMERS AND SPONGES:

RAMMER, B.L., WOOD STAVE, 6-INCH

Each cost 4/6¹⁴⁰

SPONGE, B.L., WOOD STAVE, 6-INCH¹⁴¹

RANGE FINDER, DEPRESSION

see section on DRF, above, and Appendix D.

REPOSITORY STORES

The proper title for these is "Stores for gun and repository drills, and for general instruction." As is suggested by the title, they were training stores. All of them are items

duplicated in the general equipment lists. As a RGA Service company would almost certainly have had them, the question is how many of them would have been at Rodd Hill. At certain times (summer camp), at least some of them would have been.

A complete list of the authorized stores is available in the Regulations for the Equipment of the Regular Army. Part 2.- Section XII (a)..., pp. 31-9.¹⁴²

RESERVOIRS, COMPRESSED AIR

A steel cylinder of compressed air for charging the HP carriage.

Each cost £8..1..0.¹⁴³

RIFLE, AIMING, BRUSH

A 1-inch brush for cleaning the aiming rifle.

Each cost 2/8.¹⁴⁴

RIFLE, AIMING, ROD

A wooden rod for the rifle, aiming, brush (q.v.)

Each cost 3/9.¹⁴⁵

RIFLE, AIMING, MORRIS

The 1-inch aiming rifle used with the 6-inch gun.

Each cost £47..10..0¹⁴⁶

For further information, see Appendix I.

The aiming rifle was also listed in the equipment lists as the sum of its component parts and auxiliary equipment, which are enumerated below:

RIFLE, AIMING, MORRIS:

BARREL

BLOCK RETAINING ELECTRIC NEEDLE

BREECH PIECE

DISCS, EXTRACTING

FRAMES, EXPANDING

NEEDLES, PERCUSSION

NEEDLES, ELECTRIC

TOMMY

WRENCHES, BREECH PIECE
 WRENCHES, DISCS, EXPANDING
 WRENCHES, EXPANDING
 WRENCHES, NEEDLE¹⁴⁷

For more information on these, see Appendix I.

RIMMERS, VENT, AXIAL

A bronze implement for clearing the vents of B.L. guns.
 ("T" shaped).¹⁴⁸

ROPES, DRAG, HEAVY

3-inch white rope in 30-foot lengths.

A pair cost 16/4.¹⁴⁹

SAL-AMMONIAC¹⁵⁰

SCISSORS, LAMP

They cost 11-1/2d per pair.¹⁵¹

SCRAPER, B.L., ORDNANCE, 6-INCH to 13.5-INCH

6-foot, ash stave with brush and aluminium bronze half round
 scraper on one end.

Each cost £1..16..2.¹⁵²

SHELLAC, ORANGE.¹⁵³

SHELLS

see section on shells, above.

SHOES, MAGAZINE

For use in magazines.

Prices varied according to size.¹⁵⁴

SOAP, SOFT¹⁵⁵

SODA, CARBONATE, DRY¹⁵⁶

SPANNERS AND SPECIAL INSTRUMENTS

To complete carriage, garrison, disappearing.¹⁵⁷

SPANNERS, ARMAMENT ARTIFICERS

Set, double ended, 1-1/2 to 3/8 inch.¹⁵⁸

SPANNERS, McMAHON

15-inch iron spanner.

Each cost 4/6.¹⁵⁹

STAGES, MAGAZINE

Wood stage (3 ft. by 1 ft. by 6 in.) for stacking cartridge cylinders.

There were probably none at Rodd Hill.¹⁶⁰

STAVE, END, BORE

Wood Stave.¹⁶¹

STRAPS, TUBE, BOX

Straps (3 ft. 6 in. by 1 in.) for pocket, gun-layer, box, tube, garrison, and pocket, tube, V.S. (q.v.)

Each cost 1/-.¹⁶²

TACKLES, GUN

3-inch white rope (16 ft.) and 1 double and 1 treble 9-inch block.

The set cost £1..8..0.¹⁶³

TALLOW, RUSSIAN (OR HOME MELTED ENGLISH)¹⁶⁴

TAPE, MEASURING

50-foot tape, in leather box.

Each cost 3/6.¹⁶⁵

TAPE WHITE:

1-1/4 INCH

7/8 INCH

1/2 INCH

For sealing tin cylinders and boxes.¹⁶⁶

TELESCOPE, GARRISON

3 foot telescope with x34 magnification.¹⁶⁷

THERMOMETERS, COMMON

Measured 15 to 100 degrees F.

Each cost 1/-.¹⁶⁸

THERMOMETERS, WET AND DRY BULB

Determined atmospheric humidity; used as a guide for deciding on amount of magazine ventilation necessary.¹⁶⁹

TRAYS, SPARE PARTS

Wooden tray (25-9/16 in. square by 4-7/16 in. deep) divided into 23 compartments for keeping spare parts.¹⁷⁰

TRAY, LOADING

A steel tray for loading cartridges and projectiles.
Each cost £2..5..6.¹⁷¹

TUBES:

TUBE, VENT SEALING, ELECTRIC, P (tubes 1)

TUBE, VENT SEALING, PERCUSSION (tubes 2)

TUBE, FRICTION, DRILL (tubes, 3)

TUBE, 0.23-INCH, "E" (tubes 4)

For further information, see Appendix J.

TUBE, 0.23-INCH, BRUSHES

For cleaning all nature of Morris aiming rifle tubes.

Each cost 4-1/4d.¹⁷²

TUBE, 0.23-INCH, ROD

36-inch rod for tube, 0.23-inch brush (q.v.)

Each cost 4-1/4d.¹⁷³

WADMILTILT

Quilted mats for magazine use. Came in two sizes (14.5 ft. by 12 ft. and 9 ft. by 6 ft.)¹⁷⁴

WATER, DISTILLED¹⁷⁵

WHISTLES, ARTILLERY¹⁷⁶

WRENCHES, FIRING MECHANISM, H.¹⁷⁷

WRENCHES, KNOCK-UP, G.S.

Each cost 13/9¹⁷⁸

Consolidated Equipment Tables: Introduction

The following tables are based on the alphabetical lists contained in the earlier part of this chapter. In them, the authorized numerical quantity of each item (based on the Equipment Regulations) and the probable physical location of each is shown. The tables themselves are fairly straightforward. It must, however, be emphasised that:

(1) The exercise of drawing up this table was almost entirely theoretical. There is no guarantee that the items were present at all, let alone in the quantities specified.

(2) The list is by no means complete. It takes no account of repository stores, for example.

(3) The assignment of physical locations for the various items is based on common sense more than anything else. There is no guarantee that, even if the forts had the items specified in the quantities specified, they would have been located as indicated.

As it is virtually impossible to footnote tables, the reader is referred to the endnotes for the itemized lists earlier in the chapter for information on the derivation of the information in the tables.

UPPER BATTERY

LOWER BATTERY

<u>ITEM</u>	<u>UPPER BATTERY</u>			<u>LOWER BATTERY</u>									
	Artillery Store	Shell Store	Cartridge Store	On Gun	On Carriage	Other	Artillery Store	Shell Store	Cartridge Store	On Each Gun	On Each Carriage	Skidding Shed	Other
Bolts, stop				1b						1b			
Boxes, slide				1b						1b			
Clamps, tangent sight				2						2			
Clips, cam lever				1b?						1b?			
Contacts, safety				1b						1b			
Discs, 1	2c			2b			2			2b			
Discs, 2	2			1b			4			1b			
Discs, 3	2			1b			4			1b			
Levers, 1	1			a			2			a			
Levers, 2	1			1			1			1			
Locks, percussion	1			1b			1			1b			
Obturators	2			1b			4			1b			
Pins, 1	2c			a			2			a			
Pins, 2	2c			a			2			a			
Pins, 3	2			a			4			a			
Rings, carrier				1b						1b			
Screws, breech				1b						1b			
Sights, 1				1b						1b			
Sights, 2				1b						1b			

<u>ITEM</u>	<u>UPPER BATTERY</u>					<u>LOWER BATTERY</u>							
	Artillery Store	Shell Store	Cartridge Store	On Gun	On Carriage	Other	Artillery Store	Shell Store	Cartridge Store	On Each Gun	On Each Carriage	Skidding Shed	Other
Sights, 3				1b						1b			
Sights, 4				1b						1b			
Sockets, foresight				2						2			
Springs, 1	2			a			4			a			
Springs, 2	4			a			8			a			
Springs, 3	2			a			4			a			
Springs, 4	2			a			4			a			
Springs, 5	2			a			4			a			
Springs, 6	2c			a			2			a			
Springs, 7	2			a			4			a			
Springs, 8	2			a			4			a			
Springs, 9	2			a			4			a			
Springs, 10	2			a			4			a			
Strikers, 1	4			1b			8			1b			
Strikers, 2	1			1b			2			1b			
Triggers, Lock	1d			1b			1			1b			
Vent, axial	1			1b			2			1b			

Consolidated Equipment Tables: Gun Equipment Notes

- a unknown quantity issued with gun
- b removed to artillery store when not in use
- c 1 per 2 guns authorized as spare
- d 1 per 2 guns authorized as spare

ITEM	UPPER BATTERY					LOWER BATTERY							
	Artillery Store	Shell Store	Cartridge Store	On Gun	On Carriage	Other	Artillery Store	Shell Store	Cartridge Store	On Each Gun	On Each Carriage	Skidding Shed	Other
<u>Carriage Body:</u>													
Carriage, body, without fittings					a						a		
Arcs, indicator					1						1		
Arcs, traversing					1						1		
Bearings, 1					2						2		
Bearings, 2					2						2		
Bearings, 3					1						1		
Bearings, 4					1						1		
Brackets, 1					2						2		
Brackets, 2					1						1		
Brackets, 3					1						1		
Brackets, 4					4						4		
Brackets, 5					1						1		
Brackets, 6					2						2		
Buffer stops					2						2		
Cable, electric					1b						1b		
Connections	1c				1		1c				1		
Cotters, 1					4						4		

Consolidated Equipment Tables: Carriage Equipment

<u>ITEM</u>	<u>UPPER BATTERY</u>					<u>LOWER BATTERY</u>							
	Artillery Store	Shell Store	Cartridge Store	On Gun	On Carriage	Other	Artillery Store	Shell Store	Cartridge Store	On Each Gun	On Each Carriage	Skidding Shed	Other
Cotters, 2					4						4		
Cylinder, recoil					1						1		
Cylinder, recoil, bracket, 1 & 2.					1d						1d		
Cylinder, recoil, bracket, 3					1						1		
Cylinder, recoil, caps 1					1		1				1		
Cylinder, recoil, gland					1						1		
Cylinder, recoil, packing					2e						2e		
Cylinder, recoil, plugs, 1					1						1		
Cylinder, recoil, plugs, 2	1				8		1				8		
Cylinder, recoil, plugs, 3					1						1		
Cylinder, recoil, ram					1						1		
Cylinder, recoil, rings, 1					1						1		
Cylinder, recoil, rings, 2	1				1		1				1		
Cylinder, recoil, rings, 3					1						1		

ITEM	UPPER BATTERY					LOWER BATTERY					Other	
	Artillery Store	Shell Store	Cartridge Store	On Gun	On Carriage	Artillery Store	Shell Store	Cartridge Store	On Each Gun	On Each Carriage		Skidding Shed
Cylinder, recoil, springs	2				13	4				13		
Cylinder, recoil, tubes					1					1		
Cylinder, recoil, valves, 1					1					1		
Cylinder, recoil, valves, 2	1				1	1				1		
Cylinder, recoil, valves, 3	1				1	1				1		
Cylinder, recoil, valves, 4					1f					1f		
Cylinder, recoil, valves, 5					1f					1f		
Cylinder, recoil, valves, 6	1				1	1				1		
Cylinder, recoil, washers, 1					1					1		
Cylinder, recoil, washers, 2					1g					1g		
Elevator, without fittings					1					1		
Elevator, capsquares, left					1					1		
Elevator, capsquares, right					1					1		

<u>ITEM</u>	<u>UPPER BATTERY</u>					<u>LOWER BATTERY</u>					Skidding Shed	Other	
	Artillery Store	Shell Store	Cartridge Store	On Gun	On Carriage	Other	Artillery Store	Shell Store	Cartridge Store	On Each Gun			On Each Carriage
Elevator, keys					2						2		
Elevator, pins					2						2		
Gauges, Pressure, No. 2	1h						1h						
Gauges, pressure, No. 3	1h						1h						
Guards, 1					1						1		
Guards, 2					1						1		
Guards, 3					1						1		
Guides, 1					1						1		
Guides, 2					1						1		
Hooks, stowing					2						2		
Keys	1gh				1g		1gh				1g		
Ladders, sighting, front					1						1		
Ladders, sighting, rear, left					1						1		
Ladders, sighting, rear, right					1						1		
Lanyard	1i				j		1i				j		
Pedestal					1						1		
Pillars, shield (8)					1k						1k		

<u>ITEM</u>	<u>UPPER BATTERY</u>					<u>LOWER BATTERY</u>							
	Artillery Store	Shell Store	Cartridge Store	On Gun	On Carriage	Other	Artillery Store	Shell Store	Cartridge Store	On Each Gun	On Each Carriage	Skidding Shed	Other
Pistons, 1					1					1			
Pistons, 2					2					2			
Plates, 1					1L					1L			
Plates, 2					1					1			
Plates, 3					1					1			
Plates, 4					1					1			
Plates, 5					1					1			
Plates, 6					2					2			
Plates, 7					2					2			
Plates, 8	1h				1		1h			1			
Plates, 9	1h				2		1h			2			
Plates, 10					1					1			
Plates, 11					1					1			
Plates, 12					1					1			
Plates, 13					1					1			
Plates, 14					1					1			
Plates, 15					1					1			
Plates, 16					1					1			
Plates, 17					1					1			

<u>ITEM</u>	<u>UPPER BATTERY</u>					<u>LOWER BATTERY</u>							
	Artillery Store	Shell Store	Cartridge Store	On Gun	On Carriage	Other	Artillery Store	Shell Store	Cartridge Store	On Each Gun	On Each Carriage	Skidding Shed	Other
Plates, 18				1						1			
Plates, 19				1						1			
Plates, 20				1						1			
Plates, 21				1						1			
Plates, 22				1						1			
Plates, 23				1						1			
Plates, 24				1						1			
Plates, 25				1						1			
Plates, 26				1						1			
Plates, 27				1						1			
Plates, 28				1						1			
Plates, 29				1						1			
Plates, 30				1						1			
Pointer, arc traversing				1						1			
Pointer, indicating				1						1			
Racers				1						1			
Roller ring				1						1			
Roller ring axles				16						16			
Roller ring roller				16						16			

: UPPER BATTERY

: LOWER BATTERY

<u>ITEM</u>	<u>UPPER BATTERY</u>					<u>LOWER BATTERY</u>							
	Artillery Store	Shell Store	Cartridge Store	On Gun	On Carriage	Other	Artillery Store	Shell Store	Cartridge Store	On Each Gun	On Each Carriage	Skidding Shed	Other
Rollers, guide					2						2		
Shield					1						1		
Socket					1						1		
Spindles					1						1		
Springs, disc	10h				8		10h				8		
Standard, 1					1						1		
Standard, 2					1						1		
Stays					8						8		
Steps, sighting:													
bracket, 1					2						2		
bracket, 2					2						2		
bracket, 3					1						1		
bracket, 4					1						1		
bracket, 5					1						1		
bracket, 6					1						1		
clutch, 1					1						1		
clutch, 2					1						1		
counterweight					2						2		
hooks	1				2		2				2		

<u>ITEM</u>	<u>UPPER BATTERY</u>					<u>LOWER BATTERY</u>						
	Artillery Store	Shell Store	Cartridge Store	On Gun	On Carriage	Artillery Store	Shell Store	Cartridge Store	On Each Gun	On Each Carriage	Skidding Shed	Other
levers, 1					4					4		
levers, 2					2					2		
levers, 3					2					2		
links, 1					2					2		
links, 2					2					2		
pads					4					4		
pawls, 1					1					1		
pawls, 2					1					1		
pieces					4					4		
rods					4					4		
rounds, 1					2					2		
rounds, 2					2					2		
shafts, 1					2					2		
shafts, 2					2					2		
springs	1				2	2				2		
steps, 1					1					1		
steps, 2					1					1		

<u>ITEM</u>	<u>UPPER BATTERY</u>					<u>LOWER BATTERY</u>							
	Artillery Store	Shell Store	Cartridge Store	On Gun	On Carriage	Other	Artillery Store	Shell Store	Cartridge Store	On Each Gun	On Each Carriage	Skidding Shed	Other
<u>Gear, Elevating:</u>													
Arcs, right					1						1		
Arcs, right					1						1		
Band, friction					1						1		
Cone, friction					1						1		
Drum, break					1						1		
Pawls, break					1						1		
Pins, 1					1						1		
Pins, 2					1						1		
Pointer, elevating					1						1		
Rods, elevating, left					1						1		
Rods, elevating, right					1						1		
Shafts, 1st motion					1						1		
Shafts, 2nd motion					1						1		
Springs, disc, no. 15	1				3		2				3		
Springs, disc, no. 17	1				1		2				1		
Wheel, hand					1						1		
Wheel, spur					1						1		

<u>ITEM</u>	<u>UPPER BATTERY</u>					<u>LOWER BATTERY</u>					Skidding Shed	Other	
	Artillery Store	Shell Store	Cartridge Store	On Gun	On Carriage	Other	Artillery Store	Shell Store	Cartridge Store	On Each Gun			On Each Carriage
<u>Gear, Elevation Indicator:</u>													
Brackets, 1					1						1		
Brackets, 2					1						1		
Plate					1						1		
Pointer					1						1		
<u>Gear, Pump, Lowering:</u>													
Handles					1						1		
Levers, 1	1h				1	1h					1		
Levers, 2	1h				1	1h					1		
Levers, 3	1h				1	1h					1		
Links					1						1		
Pipes, suction	1h				1	1h					1		
Pipes, delivery	1h				1	1h					1		
Pump, body					1						1		
Pump, boxes					1						1		
Pump, glands					2						2		
Pump, packing	1m				1m	2m					2m		
Pump, plugs, guide valves					2						2		

ITEM	UPPER BATTERY					LOWER BATTERY							
	Artillery Store	Shell Store	Cartridge Store	On Gun	On Carriage	Other	Artillery Store	Shell Store	Cartridge Store	On Each Gun	On Each Carriage	Skidding Shed	Other
Pump, plugs, stopping rings					2						2		
Pump, rings					1						1		
Pump, rods, guide					1						1		
Pump, rods, plunger					1						1		
Pump, springs, 1	2				2		4				2		
Pump, springs, 2	2				2		4				2		
Pump, valve, delivery	1h				2		1h				2		
Pump, valve, delivery	1h				2		1h				2		
Washers, 1					1g						1g		
Washers, 2					1g						1g		
Shafts, 1	1h				1		1h				1		
Shafts, 2	1h				1		1h				1		
<u>Gear, Raising Valve:</u>													
Boxes, stuffing	n				1	n					1		
Glands					1						1		
Levers, 1					1						1		
Levers, 2					1						1		
Levers, 3					1						1		

<u>ITEM</u>	<u>UPPER BATTERY</u>					<u>LOWER BATTERY</u>							
	Artillery Store	Shell Store	Cartridge Store	On Gun	On Carriage	Other	Artillery Store	Shell Store	Cartridge Store	On Each Gun	On Each Carriage	Skidding Shed	Other
Links					1						1		
Packing	1m0				1m		1m0				1m		
Plates					1						1		
Rack					1						1		
Ring					1						1		
Rods					1						1		
Shafts					1						1		
Spindles	1h				1		1h				1		
<u>Gear, Sighting:</u>													
Arm					1						1		
Brackets					1						1		
Carrier					1						1		
Drum					1						1		
Flap					1						1		
Lever					1						1		
Link					1						1		
Pillars, foresight					1						1		

ITEM	: <u>UPPER BATTERY</u>					: <u>LOWER BATTERY</u>					: : : :		
	Artillery Store	Shell Store	Cartridge Store	On Gun	On Carriage	Other	Artillery Store	Shell Store	Cartridge Store	On Each Gun		On Each Carriage	Skidding Shed
Pillars, tangent sight					1						1		
Pillar, supporting					1						1		
Posts					2						2		
Rod					1						1		
Sights, 1					1						1		
Sights, 2					1						1		
Slide					1						1		
Stud					1						1		
<u>Gear, Traversing:</u>													
Pistons, bevel					2						2		
Pistons, spur					2						2		
Wheel, bevel					2						2		
Wheel, spur					2						2		
<u>Platform, Landing:</u>													
Brackets, 1					1						1		
Brackets, 2					1						1		
Brackets, 3					2						2		

: UPPER BATTERY: LOWER BATTERY

<u>ITEM</u>	<u>UPPER BATTERY</u>					<u>LOWER BATTERY</u>							
	Artillery Store	Shell Store	Cartridge Store	On Gun	On Carriage	Other	Artillery Store	Shell Store	Cartridge Store	On Each Gun	On Each Carriage	Skidding Shed	Other
Brackets, 4					1						1		
Brackets, 5					1						1		
Ladders, 1					1						1		
Ladders, 2					1						1		
Lever, stop					1						1		
Platform, left					1						1		
Platform, right					1						1		
Steps					1						1		
Rail					2						2		
Shafts					1						1		
Stays, 1					1						1		
Stays, 2					1						1		
Stays, 3					1						1		
Stays, 4					1						1		
Stays, 5					1						1		
Stays, 6					1						1		
Stays, 7					1						1		
Steps, intermediate					2						2		
Steps, sighting					1						1		

Consolidated Equipment Tables: Carriage Equipment Notes

- a is carriage
- b 1 lead per gun
- c 1 spare per works with 10 guns or less
- d 1 each
- 3 2 lengths
- f plus 1 set per station spare
- g set
- h per work
- i per 2 guns
- j unknown quantity issued with carriage
- k 1 each of 8
- l pair
- m length
- n 1 spare authorized per section of defence
- o in ordnance charge; therefore not likely to have been at Rodd Hill.

ITEM	: <u>UPPER BATTERY</u>					: <u>LOWER BATTERY</u>					:		
	Artillery Store	Shell Store	Cartridge Store	On Gun	On Carriage	Other	Artillery Store	Shell Store	Cartridge Store	On Each Gun		On Each Carriage	Skidding Shed
Range-finder, depression:						A						B	
Cover, instrument on base plate, Mk. I						1							
Cover, instrument on base plate, Mark II												1	
Hoods						1						1	
Lamps						c						c	
Nuts, round						4						4	
Pins						1d						1d	
Telescope, diaphragm						1d						1d	

Notes:

Typical parts and spares for 1 Mark I and 1 Mark II DRF. Not intended to show actual DRF equipment at Rodd Hill.

A. Typical Mk.I, B Typical Mk. II, c see "Lamps" in Stores table, d spare.

ITEM	UPPER BATTERY					LOWER BATTERY							
	Artillery Store	Shell Store	Cartridge Store	On Gun	On Carriage	Other	Artillery Store	Shell Store	Cartridge Store	On Each Gun	On Each Carriage	Skidding Shed	Other
Bags, sand	1						2						
Barrows, magazine lamps						1a							2a
Barrows, magazine lamps, trays						3ab							
Bars, crow	1						1						
<u>Battery and Key:</u>													
Battery and key, box	1						2						
Battery and key, saddle					1					1			
Battery, LeClanche, cells	c						c						
Bearer, cartridge cylinder			2d									4d	
Bits, vent	1						2						
Block, driving	1						2						
Boots, magazine						2e							2e
Boxes, grease	1f						2f						
Boxes, obturating pads	1						2						
Boxes, spare parts	1						2						
Boxes, tube						1g							2g
Brushes, flue	1						1						

ITEM	: <u>UPPER BATTERY</u>					: <u>LOWER BATTERY</u>							
	Artillery Store	Shell Store	Cartridge Store	On Gun	On Carriage	Other	Artillery Store	Shell Store	Cartridge Store	On Each Gun	On Each Carriage	Skidding Shed	Other
Brushes, plasaba	2						2						
Brushes, water, carriage	2						4						
Buckets, sponge	1						2						
Cans, lubricating	1f						2f						
Cans, oil	1f						1f						
Cans, oil, feeding	1f						1f						
Canvas	2 $\frac{1}{2}$ yds.h						5 yds.h						
Cartridges, 1			31								31		
Cartridges, 2			11								11		
Cartridges, 3			21								21		
Carts, trench	1j												
Cases, cartridge			2								4		
Cases, large clinometer	1						1						
Chalk	1 box						2 boxes						

ITEM	: <u>UPPER BATTERY</u>					: <u>LOWER BATTERY</u>					Other	
	Artillery Store	Shell Store	Cartridge Store	On Gun	On Carriage	Artillery Store	Shell Store	Cartridge Store	On Each Gun	On Each Carriage		Skidding Shed
Chests, tool	1					1						
Glinometer, large	1k					1k						
Composition	2oz.fh					2oz.fh						
Cotton, white waste	6lb.h					12lb.h						
Cotton, old sheeting	2lb.h					4lb.h						
Covers, breech				1					1			
Covers, carriage					1					1		
Covers, gear, firing					1					1		
Covers, muzzle				1					1			
Cylinders, cartridge			l					L				
Cylinder, cartridge, BL			1m					1m				
Drivers, grummet		1					1					
Drivers, 1	1					1						
Drivers, 2	1					1						
Drivers, 3	1					2						
Drug, gun											1	
Dubbing	½lb.h					1lb.h						

ITEM	UPPER BATTERY					LOWER BATTERY							
	Artillery Store	Shell Store	Cartridge Store	On Gun	On Carriage	Other	Artillery Store	Shell Store	Cartridge Store	On Each Gun	On Each Carriage	Skidding Shed	Other
Extractors, drill shell	1						2						
Extractors, tube P	1						3n						
Extractors, tube P special	1						1						
Filters	1o											1	
Frames, store	1o											1	
Fuzes, 1						p							p
Fuzes, 2						p							p
Fuzes, 3						p							p
Fuzes, 4	1q						2q						
Fuzes, 5	r						r						
Gauges, striker	1						1						
Glycerine	4lbs.fh						8lbs.fh						
Grease	4lbs.fh						8lbs.fh						
Grummets		2i											
Gyns												1	
Hammers	1						1						
Handspikes	2plus						4plus						

ITEM	UPPER BATTERY					LOWER BATTERY							
	Artillery Store	Shell Store	Cartridge Store	On Gun	On Carriage	Other	Artillery Store	Shell Store	Cartridge Store	On Each Gun	On Each Carriage	Skidding Shed	Other
Holders, shell		1s						1s					
Implements, 1		1						1					
Implements, 2		1						1					
Indicator, range						1t							1t
Jacks	1o												
Knives						1a							1a
Lamp, electric telescope	u						u						
Lamp, Electric telescope, box						1v							1v
Lamp, electric telescope, lead						1v							1v
Lamp, electric telescope, switch						1v							1v
Lamp, electric telescope, plug						1v							1v
Lamps, fighting	3						8						1w
Lamps, magazine, partition						3a							3a

ITEM	: <u>UPPER BATTERY</u>					: <u>LOWER BATTERY</u>					Other		
	Artillery Store	Shell Store	Cartridge Store	On Gun	On Carriage	Artillery Store	Shell Store	Cartridge Store	On Each Gun	On Each Carriage		Skidding Shed	
Lamp, magazine, wall												2a	3a
Lantern, bullseye	4					7							
Lantern, magazine												1a	1a
Lanyards	3					6							
Leathers	2f					3f							
Linen	4lbs.h					8lbs.fh							
Luting	x					x							
Magazine clothing												e	e
Mallet, tinmans		2					3						
Measures, glass	1					1							
Measures, hydraulic buffer	1					1							
Methylated spirits	?					?							
Mineral jelly	3lbs.h					6lbs.h							
Oakum	2lbs.h					4lbs.h							
Oil, instrument													1pint,hy
Oil, luting	$\frac{1}{2}$ gill,fhz												$\frac{1}{2}$ gill,hyz
Oil, mineral	?f												?y

ITEM	UPPER BATTERY			LOWER BATTERY					Other				
	Artillery Store	Shell Store	Cartridge Store	On Gun	On Carriage	Other	Artillery Store	Shell Store		Cartridge Store	On Each Gun	On Each Carriage	Skidding Shed
Oil, olive	2pints, fh												2pints,hy
Oil, Paraffin	2gals.fh 1pint,fh												2gals,hy 2-3pints,hy
Oil, Rangoon	12gals,fh												12gals.hy
Pad, frame	1o											1	
Plank		1						1					
Plugs, 1		1aa						1aa					
Plugs, 2													1bbcc
Plugs, 3	1dd						1dd						
Pocket	1						2						
Potash	2lbs,h						4lbs,h						
Rammers and sponges, rammer	2						2						
Rammer and sponges, sponges	2						4						
Range-finder	ee						ee						
Reservoirs	1						2						
Rifle, aiming, brush	1						2						
Rifle, aiming, rod	1						2						

<u>ITEM</u>	<u>UPPER BATTERY</u>					<u>LOWER BATTERY</u>							
	Artillery Store	Shell Store	Cartridge Store	On Gun	On Carriage	Other	Artillery Store	Shell Store	Cartridge Store	On Each Gun	On Each Carriage	Skidding Shed	Other
Rifle, aiming, morris:													
Barrel	1						2						
Block	1						2						
Breech	1						2						
Disc	10						10						
Frames	1						2						
Needles, electric	1ff						2ff						
Needles, percussion	1ff						2ff						
Tommy	1						2						
Wrenches, breech	1						2						
Wrenches, disc	1						2						
Wrenches, expanding	1						2						
Wrenches, needle	2						4						
Rimmer, vent axial	2gg						4gg						
Ropes, drag	2pair											2pair	
Sal-ammoniac	1lb.hh						1lb.hh						
Scissors, lamp						1a							1a
Scraper	1						2						

<u>ITEM</u>	<u>UPPER BATTERY</u>					<u>LOWER BATTERY</u>					Other	
	Artillery Store	Shell Store	Cartridge Store	On Gun	On Carriage	Artillery Store	Shell Store	Cartridge Store	On Each Gun	On Each Carriage		Skidding Shed
Shellac, orange	ii					ii						
Shell, B.L., 6-Inch:												
Armour-piercing		230jj					540jj					
Common pointed		60jj					42jj					
Common Lyddite		200jj					400jj					
N. P. Shot		10jj					18jj					
Shrapnel		50jj					140jj					
Shoes, magazine						2pairs,e						2pairs,e
Soap, soft	kk					kk						
Soda	?					?						
Spanners	1set					1set						
Spanners, armament artificers	1set					1set						
Spanners,McMahon	1					2						
Stages		1						2				
Staves	2					2						
Straps	1					1mm	2					2mm
Tackles	2										2	
Tallow	2lbs. plus,h					4lbs. plus,h						

ITEM	: <u>UPPER BATTERY</u>					: <u>LOWER BATTERY</u>							
	Artillery Store	Shell Store	Cartridge Store	On Gun	On Carriage	Other	Artillery Store	Shell Store	Cartridge Store	On Each Gun	On Each Carriage	Skidding Shed	Other
Tape, measuring	nn						nn						
Tape, white	LL						LL						
Telescope	1						1						
Thermometer			1						1				
Thermometer, wet and dry						loo							lpp
Trays, spare parts	1						1						
Trays, loading	1or2qq						3qq						
Tubes, 1						1rr,ss							1rr,ss
Tubes, 2						125ss							250ss
Tubes, 3						1ss							2ss
Tubes, 4						1ss							2ss
Tube, .023-in, brush						1ss							2ss
Tube, .023-in., rod						1ss							2ss
Wadmiltilt			LL						LL				
Water, distilled	?						?						
Whistles	1						1						
Wrenches, firing mechanism	1						2						
Wrenches, knock-up	1						1						

Consolidated Equipment Tables: Stores Notes

- a lamp room
- b on barrow
- c various types in various quantities: at least 1 cell for each Battery and Key, Test and Firing; at least 4 "C" cells for each DRF and 25% of the total in addition as spare.
- d most likely here, if anywhere in Rodd Hill
- e shifting lobby
- f or possibly in the oil store, lower battery
- g tube and fuze recess
- h annual allowance
- i per shell, total numbers not known
- j authorized per sub-district: I have placed it in Upper Battery which had the larger artillery store
- k in Cases, Large Clinometer
- l as authorized: may also have been in the cartridge recess
- m may also have been in the artillery store or the cartridge recess
- n includes 1 spare
- o probably
- p 1 per round authorized; total numbers not known. Could have been in the shell, in the tube and fuze recess or in the artillery store.
- q 1 per shell holder
- r 1 per drill shell when lyddite shells were in use
- s may have been in the artillery store
- t possibly kept at emplacement under cover of the shield

u 1 per DRF telescope and 1 per DRF spare
v on each DRF pedestal, if anywhere
w for the BC Post; perhaps kept there
x 7 oz. per 100 shells authorized; it came in 1 lb.
cylinders
y probably in oil store
z per 100 shells
aa per shell taking base fuze
bb 1 per Lyddite shell
cc Lyddite shell store
dd for drill
ee see DRF equipment table
ff plus 2 per district spare
gg includes 1 spare per gun
hh per Le clanche cell
ii as required
jj as of 1902; see above, "Shells"
kk 5 lbs per 5 guns, annual allowance
ll as required
mm fuze and tube recess if Box, Tube stored there;
otherwise artillery store
nn 1 authorized; could have been in either
oo in louvered shelter just inside gate
pp in louvered shelter on south wall of artillery store
qq 1 spare
rr per round; total number not known
ss tube and fuze recess; may also have been in artillery
store.

Appendices. An Introductory Note

With the exception of Appendix 1, the following appendices all refer to the List of Changes in War Matériel and of Patterns in Military Stores.... It might, therefore, be worthwhile to begin with an explanation of the List of Changes, and a comment on the nature of the material in these appendices.

The List of Changes was (and may still be; the most recent volume the author has seen dates from 1957) a published inventory of military stores and changes in military stores. It was first issued in 1860. The store items were divided up into numbered paragraphs, and these numbered paragraphs were the basis of the identification system, such as it was. It should be noted that individual items were given paragraph numbers (apparently) on the basis of chronological approval date: in other words, first come, first served.

Although the List is indexed, it is, for the most part, indexed by year. Cumulative indices exist for 1883-89 and 1890-1900. These are exceptions. Even the cumulative indices do not always give all the paragraph entries under a single name.

For the most part, the List of Changes entries are mutually dependent. (i.e. Item A is similar to Item B except for...) and tracing the development of a particular piece of equipment through the volumes is much like following a very boring soap opera. This also makes it difficult to transmit the information gained from going through the List in any

comprehensible form. These appendices attempt only to suggest some of the major items present in the Rodd Hill equipment, but it should be understood that the listing is not complete and that further work ought be be done on each item (not to mention the minor items which are not treated here at all).

The appendices based on the List are of two sorts. Those for the gun, the carriage and the DRF (Nos. 2, 3 and 4) are bibliographic. They provide a listing of the paragraphs dealing with the item in question from its initial introduction down to 1904. The intent is to give some idea of the type of information available in the List, and to provide a basic guide to the changes in the item.

In the other appendices, quotation from individual paragraphs is used to provide descriptions of the item. As is apparent from the above discussion, this method presents many problems and, in several appendices, it has not been entirely successful. As the appendices were assembled from research notes at a time when the author did not have access to a complete set of the List, occasionally the paragraph quoted will refer to a paragraph which is not included in the appendix. Frequently an entry will begin "a pattern has been sealed" (meaning that, at one time, there existed a specimen or drawing of the item in question) and no further useful information is forthcoming. These appendices do not, therefore, even begin to supply all the necessary information even for the relatively limited range of subjects treated.

As in both the following and the endnotes, List of Changes items are always cited by paragraph. Table 6 is provided to give the year that corresponds with each paragraph. The paragraphs for the year 1901 were unavailable in the collection used by the author. There may, therefore, be information in the paragraphs for that year which was unavailable for the writing of this report.

Table 6. Year Correspondence of the List of Changes Paragraphs (to 1904).

1860-68	1 - 1516
1869-73	1562 - 2542
1874-79	2543 - 3645
1880-82	3646 - 4190
1883-84	4191 - 4606
1885-86	4607 - 5123
1887-88	5124 - 5602
1889	5603 - 5893
1890	5894 - 6204
1891	6205 - 6578
1892	6579 - 6939
1893	6930 - 7292
1894	7293 - 7642
1895	7643 - 8073
1896	8074 - 8516
1897	8517 - 8930
1898	8931 - 9319
1899	9320 - 9927
1900	9928 - 10369
1901	10370 - 10796*
1902	10797 - 11366
1903	11367 - 11944
1904	11945 - 12524

*this year unavailable.

Appendix A. Notes on Lamp Recesses (from Great Britain, Army, Corps of Royal Engineers, Permanent Fortification for English Engineers, by Major J.F. Lewis. [Chatam: R.E. Institute, 1890], pp. 146-9).

Lamp Recesses - The forms of lamp recess are many, most of them being only rendered necessary by want of arrangement in laying out the lamp passages, or by the exigencies of alterations to old works.

The simplest form, and the only one generally necessary to use, is a rectangular hole cut through the wall, and closed at the end by a pane of glass set in a brass frame. This frame is 1 inch wide all round, and 1/4 inch thick. From it projects a rib 1/2 inch thick and 3/8 inch deep. To this rib is secured a flat frame of brass, 1 inch wide and 1 inch thick, the inner superficial dimensions of these two frames being the same, and in the space between them is fitted the indiarubber in which the glass is set. The india rubber may be a tube, slit down. This separation of the glass from the brass by strips of indiarubber has been found necessary to prevent it being broken from the concussion of firing. This frame should be double; the outer one fixed; the inner one hinged to it to open into the magazine, so that the glass can be got at for cleaning. It is almost impossible to clean the glass properly at the end of a long recess.

The outer frame is Z shaped, 1 inch wide and 1 inch deep. It fits round the edge of the recess, and is attached to the wall by lugs and screws. To it is hinged the inner

frame.

The frame is closed by a simple lock and "railway door" key.

A stop should be inserted in the floor of the recess to prevent the lamp being shoved too far forward, and a brass bar fixed across to prevent it being tilted against the glass, and an escape for the smoke may be provided above.

If the lamp recess be low down, and in such a situation that it might be struck by a man's shoulder, or the end of a cartridge cylinder, it should be protected externally by a grating of 1/4 inch brass wire.

The glass, by-the-by, should be plain strong sheet or plate glass. I have been in a magazine in which bulls-eyes of considerable curvature were used in the lamp recesses. The result was that there was a bright spot of light on the opposite wall, and the rest of the magazine was in darkness.

The smallest size used for the glass frame of a lamp recess is 1 foot 3 inches by 1 foot 3 inches; this is shorter than the lamp. The most convenient size is made to suit a recess 1 foot 9 inches high by 1 foot 3 inches wide. There are other sizes to be got, particulars of which may be found in the W.O. contracts.

It may be necessary to put two lamps back to back to light a passage in two directions. In such a case a projecting box can be procured, in plan 3 sides of an octagon, which must be set on a slate or hard stone slab. It requires an opening 2 feet wide to be cut in the wall behind it. It is usually better to have two ordinary recesses near one another.

Sometimes it is necessary to put a lamp at the end of a long recess, so that it would be beyond the reach of a man's arm. Then a little tray to carry the lamp must be used, running on small zinc rails, and pushed in or pulled out by

a stick with a hook at the end.

If it is inconvenient to use the stick, the tray can be hooked to an endless chain running over two pulleys, one at each end of the tube or recess.

Occasionally a lamp has to be passed across a magazine passage to light a chamber on the other side; in that case a tube of slate or sheet iron has to be used, down which it can be pushed on the tray just mentioned.

If it be wished to light the passage from this tube, which affords a convenient position for doing so, a glazed frame can be inserted in the side, and the lamp put on a special tray which carries it sideways.

It may sometimes be necessary to lower down a lamp to its recess from some height too great for a man to reach with his arm. In that case it can be let down by a brass chain and pulley, and guided into its place in the following manner:-

Two pins are inserted in the sides of the base of the lamp, and these pins fit in grooves cut in two boards set up, one on each side of the shaft down which the lamp is lowered, so that the lamp is guided in its descent. These grooves are curved at the lower ends, so that the lamp is moved forward close up to the glass.

Overhead Lamp.- The overhead lamp is cylindrical in form - somewhat like a railway carriage lamp, but it burns a candle like the wall lamp. The lower part, which is of glass, is 8 inches deep and 8-1/4 inches in diameter. The upper part, of copper, is 8-1/2 inches high and 9 inches diameter. The difference in the diameter of the two parts forms a shoulder on which the lamp can be supported.

The overhead lamp is always used by being lowered down a tube.

The lower end of this tube would be made of iron, and the lower edge would be either turned in, or have a ring of

angle-iron rivetted on to it to form a rim on which the lamp may rest. The rim would be covered with indiarubber. It will be seen that when the lamp is not in position, there is an open communication between the lamp passage and the magazine, which is objectionable.

A wire guard should be fixed round this lamp in low passages.

The various methods of using magazine lamps have been shortly described, as cases may occur in which the simple recess cannot be used, but all other forms should be avoided as much as possible.

Lamp Recess Doors.- When lamp recesses are in places which are accessible to others besides the lamp man, the backs must be provided with iron doors 1/4 inch thick, and locked with a key like a railway door key. This is to prevent unauthorized people meddling with the lamps, and it is also intended to diminish the chance of any accident which might knock the lamps forward into the magazine. Arrangements must be made, by air-bricks or other means, to admit air to the lamps.

When the recess is made in an outside wall, of course it becomes a small window in daytime, which is useful in places such as laboratories where work is usually carried on during the day.

Number and Position of Lamps.- The service lamps give a very good light, and not many are needed for a magazine.

Two are sufficient for an ordinary small expense store; eight as a rule are enough for each chamber of a large store magazine, two for the centre passage, and one for each side one, at each end.

Ammunition passages can be lighted from the ends if there are no bends in them. Shifting rooms should be provided with lights.

There should always be a good light near the entrances

and exits of the lifts, where hooks have to be adjusted and the winches worked, and in placing the lamps care should be taken that the men do not necessarily stand in their own light when at work.

Height above Floor.- A good height above the floor for a wall lamp is 5 feet to the under side of the recess; in a large magazine a little more, but not much, or there will be a dark space underneath.

Lamp Passages.- Lamp passages may be made 2 feet 6 inches wide, and run round or intersect the magazine buildings at the general floor level, but sometimes it is convenient to divide a passage horizontally by inserting a floor of stone, concrete, or slate slabs, and using the upper portion as a lamp passage. This upper portion need not be more than 5 feet high.

It is best to make the entrance to the lamp passage entirely distinct from that to the magazine, but it can be entered if necessary from outside the barrier in the shifting room; never from inside the barrier.

Magazine lamps may be carried into shell stores, and the latter may therefore be utilized as lamp passages if otherwise suitable. It must be remembered that the shell stores themselves must be lighted in some way, and a lamp passage is often a convenient way of doing this. If lamps are carried into a shell store, a passage-way has to be left clear for them.

Appendix B. List of Changes Entries Detailing the Evolution of the Mark VI Gun, 1883-1904 (from Great Britain, War Office, List of Changes in War Matériel and Patterns of Military Stores... [London: HMSO, 1883-1904], paragraphs as noted).

4757 Initial entry for Mark III gun. The Mark VI was similar.

5367 Initial entry for Mark IV gun. The Mark VI was similar.

6278 Initial entry for the Mark VI gun.

6656 Strengthened pattern for spring, cam lever catch.

7116 Initial entry, lanyard guide.

7156 Alteration to planes for clinometer.

7374 Alterations to lanyard guide and lanyard guide brackets.

7375 Fitting of check screw for carrier ring.

7830 Alteration to percussion locks.

8174 Repairs to carrier ring.

8803 Alteration to cam levers and change in nomenclature.

8837 Alteration of fore and tangent sights.

9029 Alteration of breech fittings.

9050 Initial entry for Mark VI A Gun.

9153 Alteration to fore and tangent sights.

10073 Alteration to lengthening lever, change in nomenclature.

10231 Repair to recess for carrier ring retaining clip.

10319 Addition of safety block.

11219 Alteration of lock, percussion "K" and change of nomenclature.

Appendix C. List of Changes Entries Detailing the Evolution of the Mark IV Carriage, 1889-1904 (From Great Britain, War Office, List of Changes in War Matériel and of Patterns in Military Stores... [London: HMSO, 1889-1904], paragraphs as indicated).

- 5912 Initial entry, Mark II carriage.
- 5913 Initial entry, Mark III carriage.
- 5914 Initial entry, Mark IV carriage.
- 5941 Plug for air chamber.
- 6086 Springs of lowering pump.
- 6111 Alteration of cut-off gear.
- 6129 Alteration to valves.
- 6311 Alteration to recoil valve.
- 6416 Strengthened racers.
- 6449 Strengthened chain to pin securing elevator.
- 6483 Alterations to recoil valve.
- 6639 Cut-off chain.
- 6731 Man hole.
- 6771 Lead for lanyards.
- 6902 Holes, capsquares.
- 7037 Stuffing, box for raising valve.
- 7102 Electric firing gear.
- 7171 Alteration of copper tube.
- 7193 Draw-off tube, Mark I.
- 7222 Alteration, packing, recoil cylinder.
- 7300 Ditto.
- 7472 Alteration to air plug.
- 7583 Disc springs for buffer stops.

7623 Altered method of fixing racers.
8046 Yard scale plates.
8086 Disc springs for buffer stops.
8130 Sighting step and landing platform fitted.
8169 Lever, socket handle of lowering pump gear strengthened.
8341 Arrangement of leads, electric firing.
8523 Sighting step and landing platform.
8590 Screws, securing bush, crosshead bearings.
8863 Keyways to be cut in ram.
8904 Leads of safety arrangements.
9025 Alteration to air plug of recoil cylinder.
9046 Battery leads.
9140 Valve sealing for water level valve.
9189 Leads for electric firing.
9220 Bracket supporting firing key.
9222 Stop-valves, modification to.
9329 Leads of safety arrangement.
9376 Practice to be carried out with 3/4 charge E.X.E. gunpowder, after valves are set for cordite.
9428 Shield sights.
9429 Sighting step to be fitted in closed pits.
9486 Marks on elevator and bracket pin joint elevator.
9487 Sighting platform for shieldless carriages.
9550 Removal of spring sighting step.
9600 Rod with slotted link to replace cut-off chains.
9656 Alteration to recoil valve.
9709 Sighting platform.
9710 Cable electric D9 to be used for battery leads.
9711 Electric leads for use with shield sights.
9756 Pointer and arrow plate. 9486 cancelled.
9943 Air relief valve.
9944 Transom in air relief valve.
10058 Sighting Step.

- 10318 Yard plate scale.
- 10819 Coning of top and bottom rings of ram glands.
- 10820 Water level valve.
- 10878 Initial entry, Gauges, pressure, nos. 1-3.
- 11380 Modification, electric firing.
- 11426 Gauges, pressure, nos. 2, 3.
- 11936 Fitting of sighting gear.
- 12234 Removal of landing platforms and intermediate steps.
- 12348 Sight pillars.

Appendix D. List of Changes Entries Detailing the Evolution of the DRF, 1883-1904 (from Great Britain, War Office, List of Changes in War Matériel and of Patterns in Military Stores... [London: HMSO: 1883-1904], paragraphs as indicated).

- 4502 Initial entry, Watkin Depression range finder (Mark I)
- 4690 Initial entries, Marks Ia, Ib, Ic.
- 5514 Base plate and base plate cover.
- 6062 Lamp, electric, telescope.
- 6064 Telescope shade.
- 6135 Alterations to 6062, 6064.
- 7158 Initial entry, Mk. Id.
- 8324 Initial entries, Marks II, IIa, IIb, IIc and base plate cover for same.
- 8819 Case, base plate (Mark I) and Spanner, alterations and fittings.
- 9171 Marks Ib and IIb alterations.
- 9525 Alteration in fittings of cases.
- 9870 Nomenclature changes.
- 10153 Initial entry, Mk. II d.
- 10182 Initial entries, Mk. I special and Mk. II special.
- 10245 Alterations in nomenclature.
- 11258 Ditto.
- 11593 Ditto.
- 11650 Ditto.
- 12385 Initial entry, Telescope, overhead, Mk. I.

Appendix E. Contents of Chest, Tool, Filled, No. 11 E (from Great Britain, War Office, List of Changes in War Matériel and Patterns of Military Stores... [London: HMSO, 1896], paragraph 8718).

Chest, Tool, Filled, No. 11 E.

Carriage Smiths, R.A., Garrison.

Woolwich Store Charge No. 7.

1	Chest, tool, empty, no. 11.
2	Aprons, basil, brown
1	Brace, smiths'
1	Braces, smiths' bits, countersunk, rose
1	" " " rimmer, half-round
1	" " " " square
1	Braces, ratchets, 18-inch
1	" " drills, no. 1 to no. 11, set
1	pair, calipers, 10-inch
2	Chisels, hand, cold, 1-inch by 8-inch
2	" " " 3/4 inch by 8-inch
1	" rivet head
1	" smiths', cold
2	" " hot
1	pair, compasses, wing, 10-inch
1	cutter, anvil, 2-inch
1	Drivers, screw, G. S., 14-inch
1	" " " " 6-inch
10	Files, bastard, flat, 14-inch
6	" " " 10-inch
4	" " " 8-inch

4 " " half-round, 14-inch
 4 " " " 10-inch
 4 " " round, 12-inch
 2 Files, bastard, round, 8-inch
 3 " " rubbers, 0.5 inch thick, 16-inch
 1 " " three square, 12-inch
 1 " " " " , 7-inch
 2 " " square, 10-inch
 2 " " " , 8-inch
 2 " " warding, 5-inch
 2 " " " cut on one side, 3.5-inch
 1 Flatters, smiths'
 1 Fullers bottom
 1 " top
 1 Hammers, fitters', 24-oz.
 1 " " 32-oz.
 1 " smiths', hand, 3-lb.
 1 " " setting
 1 " " sledge, 10-in.
 1 " " uphand, 7-lb.
 2 Handles, file, large.
 4 " " small
 1 " " swan neck
 1 Holdalls, smiths'
 1 pair, pincers, carpenters
 1 Plates, screw, 10 taps, 20 hole
 1 pair, pliers, cutting, 7-inch
 1 Punches, centre, 4.5-inch
 2 " smiths', cold
 1 " " , hot, 5/8-inch
 1 " " " 1/2-inch
 1 " " " 3/8-inch
 4 Rods, smiths', iron
 1 Rule, carpenters', common

1 Saws, cutting metal, 10-inch
 1 " " " blade, 10-inch
 1 Snaps, hand, rivetting, 7/16-inch
 1 " " " 3/8-inch
 2 " " " 3/10-inch
 2 " " " 1/4-inch
 2 " riveting, rod, 1 5/8-inch
 2 " " " 1 1/2-inch
 2 " " " 1 3/8-inch
 2 " " " 1 1/8-inch
 2 " " " 1-inch
 2 " " " 7/8-inch
 2 " " " 3/4-inch
 2 " " " 5/8-inch
 2 " " " 1/2-inch
 1 Spanner, McMahon's, 15-inch
 1 Square, smiths', iron
 1 Stocks, drill, bevel wheel
 1 set, stocks, drill, bevel wheel, bits
 1 Stone, oil, smiths'
 1 Pair, tongs, smiths', bolt
 1 " " " fore bit
 1 " " " forge, large
 1 " " " hammers
 1 " " " hollow bit
 1 " " " plier
 1 Traveller
 1 Vise, hand, 16-oz.

Woolwich Store Charge No. 18

4 Cloths, sponge

Miscellaneous

1 Handbook, military artificers'

Woolwich Store Charge No. 7

1 Chest, stocks and dies, Whitworth thread, 1 1/8-inch to

1/4-inch, filled

Details of stocks and dies

Dies:

1 set, 1 1/8-inch
 1 set, 1-inch
 1 set, 7/8-inch
 1 set, 5/8-inch
 1 set, 1/2-inch
 1 set, 7/16-inch
 1 set, 3/8-inch
 1 set, 5/16-inch
 1 set, 1/4-inch
 1 set, 7/8-inch, fine thread
 1 set, 5/8-inch, " "
 1 set, 9/16-inch, " "

Spanners:

1 7/8-inch
 1 5/8-inch

Stocks:

1 C
 1 D

Taps:

1 1 1/8-inch, plug
 1 " " 1st turn
 1 " " 2nd turn
 1 1-inch, plug
 1 " 1st turn
 1 " 2nd turn
 1 7/8-inch, plug
 1 " 1st turn
 1 " 2nd turn
 1 3/4-inch, plug
 1 " 1st turn
 1 " 2nd turn

1 5/8-inch, plug
 1 " 1st turn
 1 " 2nd turn
 1 1/2-inch, plug
 1 " 1st turn
 1 " 2nd turn
 1 7/16-inch, plug
 1 " 1st turn
 1 " 2nd turn
 1 3/8-inch, plug
 1 " 1st turn
 1 " 2nd turn
 1 5/16-inch, plug
 1 " 1st turn
 1 " 2nd turn
 1 1/4-inch, plug
 1 " 1st turn
 1 " 2nd turn
 1 7/8-inch plug, fine thread
 1 5/8-inch " " "
 1 9/16-inch plug, fine thread

Wrenches:

1 I
 1 H
 1 F
 1 D
 1 Brace, ratchet, post, 20-inch
 1 Vice, standing, 80-lb, with iron bench.

Appendix F. Fuzes (from Great Britain, War Office, List of Changes in War Matériel and of Patterns in Military Stores... [London: HMSO, 1880-1901], paragraphs as indicated).

1. Fuzes, 1: Fuze, percussion, base, large, No. 11, Mark 1. [Paragraph 8099].

A pattern and drawing of the above-mentioned fuze have been scaled to govern manufacture.

The fuze is for use in all cast-steel common shell having pointed heads, for B.L., R.M.L., and Q.F. guns of 6-inch calibre and upwards.

The fuze consists of the following parts, viz., body, needle pellet, centrifugal bolt, pressure plate with spindle and nut, screwed cap with detonator and plug, phosphor-bronze spring, brass spring, lead washer, and four brass screws.

The body of the fuze is made of manganese bronze, screwed outside, nine threads per inch (left-hand), to fit the shell. The pressure plate is of copper, and is spun into the base of the fuze. It carries a spindle which retains the centrifugal bolt in the needle pellet, by engaging in a slot in the latter, until the pressure plate is blown in. The base of the body is recessed to admit of the pressure plate being forced in by the gas pressure when the gun is fired.

The needle pellet is made of gunmetal and has a screwed recess on top for the needle plug, and a hole bored in it at

right angles to the axis to take the centrifugal bolt, the head of which engages into a recess in the side of the body, and is kept in that position by a spiral brass spring in the opposite side of the body, and by the spindle of the pressure plate. The needle pellet is prevented from working forward in flight by a spiral spring of phosphor bronze.

The detonator is spun into a recess in the screwed cap, and communicates by six fire holes, with the magazine of M.G.¹ powder contained between the cap and the plug.

The action of the fuze is as follows: - On discharge, the pressure of the gas crushes in the pressure plate, causing the spindle to release the centrifugal bolt; the rotation of the shell causes the centrifugal bolt to be spun out, compressing the spring in rear and leaving the needle pellet free to move forward on impact, when the needle strikes the detonator and so fires the fuze.

Weight of fuze 2 lb. 8 oz.

2. Fuzes 2: Fuze, percussion, direct action, impact, no.
13. [Paragraph 3821]: Fuze, percussion, direct action (Mark I)

A pattern fuze, percussion, direct action, has been sealed to govern supplies for Land Service, in the room of the "fuze, percussion, sensitive."

The direct action fuze is not affected in any way by the discharge of the gun, whether heavy or low charges are used; but on direct impact, or on grazing at such an angle that the nose of the shell would enter into the ground, the hammer is at once driven down on to the detonating composition, which explodes, and ignites the powder in the magazine.

The head of the hammer being countersunk below the head

of the fuze, it cannot be touched or forced down on the detonating composition when ramming home with any ordinary rammer.

The metal cap is fitted for the "key, iron, general service." It is fastened on the head of the fuze (on the side of which there are two small brass studs) by a double bayonet joint. This bayonet joint enables the cap to be used either in fixing or unfixing the fuze.

The fuze requires no preparation except the removal of the metal cap, which can be easily effected by hand, by bringing the centre of the joint in line with the studs on the head of the fuze.

The cap should not, however, be removed until just after entering the shell into the bore of rifled M.L. guns, or just before entering the shell into B.L. guns.

This fuze is suitable for use in howitzers, in guns firing reduced charges, and in guns firing full charges for direct impact into earthworks, or masonry, or to act on graze, provided the angle of elevation is 10° or upwards.

Its issue will, however, be restricted to the services for which the "fuze, percussion, sensitive," was intended.

This latter fuze will be considered obsolete.

A few fuzes were originally made and issued for experimental practice, differing from the above as regards the arrangement for the metal cap, which was made to screw on to the head of the fuze and necessitated the use of a special key.

[Paragraph 8630]: Fuze, percussion, direct action, impact, no. 13.

A pattern (design R.L. 8772) has been sealed to govern manufacture, for land service, of a certain number of fuzes of the above-mentioned description, for use in 10-inch shells filled with lyddite, £8465, in R.M.L. guns on

high-angle mountings.

The fuze is fitted with a steel cap, and is, externally, similar to that described in 8482.

	oz.
Weight of fuze	10
" " cap	3

3. Fuzes 3: Fuze, time and percussion, middle, No. 54.

Paragraph 5638: Fuze, time, sensitive, long, No. 23 (Mark I)

Fuze, time, sensitive, middle, No. 24 (Mark I)

Patterns of the above-mentioned fuzes have been sealed to govern supplies.

Each consists of the following parts:-

Body (a) with stem, lighting pellet (b), two retaining pellets (cc), two spiral springs (dd), needle (e), composition ring (f), dome (g), cap (h), two safety pins (ii), base plug (k), and axial magazine (l).

All the parts are made of gunmetal, except the composition ring, which is made of phosphor-bronze.

The composition ring for the long fuze is graduated on its periphery from 0 to 60 and is marked to read units; that for the middle fuze from 0 to 30, and reads to half units. An ↓ is stamped on the ring to show the safety point, and when this coincides with the ↑ on the body the fuze is set at safety. The cap, which screws on to the top of the pillar, is made hexagonal, to fit the universal fuze key.

Action of the fuze

The fuze is set by loosening the screw cap (h) on the top of stem, by means of the "key, fuze, universal" (4934), and turning the dome and ring till the required graduation is opposite the arrow on the body, the screw cap is then clamped firmly. The safety pins are withdrawn at the moment of loading. On discharge the contrifugal action

causes the retaining pellets to fly out, releasing the lighting pellet, which flies out by centrifugal force against the needle, firing the detonator, which ignites the powder in the pellet and axial magazine, this latter lighting the quickmatch in the composition ring.

	lb.	oz.
Weight of long fuze	1	4
" middle fuze	1	4

The test for time of burning applied to these fuzes is as follows:-

When set at full length and spun in a lathe at 900 to 1,100 revolutions per minute they should ignite and burn -

Middle	14.8 to 15.4 seconds
Long	29.5 to 31.0 "

Paragraph 8417: Fuze, time, sensitive, long, no. 23.

Obsolete

Fuze, time and percussion, Middle, No. 54,
(Marks I* and II)

A pattern (design R.L. 8573A) of the above-mentioned No. 54, Mark II., fuze has been sealed to govern manufacture as follows:-

(1.) Land service -

For immediate issue in lieu of the "Fuze, time, sensitive, long, No. 23" (5638), and "Fuze, time and percussion, middle, No. 54, Mark I."

For future manufacture in lieu of "Fuze, time, sensitive, middle, No. 24."

(2.) Naval service -

For temporary use in lieu of the "Fuze, time, sensitive, middle, No. 24."

The "Fuze, time and percussion, middle, No. 51, Mark II," differs from Mark I. (5364) in having a side escape

hole similar to that in the "fuze, time and percussion, No. 56 Mark IV." (7716), in having the time ring barrel-shaped outside, so as to facilitate setting, and in having a washer between the nut and dome to prevent the dome from turning with the nut when the latter is being screwed up.

The time of burning at rest is 16 seconds when set at full length.

Each fuze is wrapped in brown paper, and packed in a hermetically-closed tin cylinder.

	lb.	oz.
Weight of fuze.... ..about	1	4
" " in tin cylinder..."	1	8

Alteration of fuzes, time and percussion, middle, No. 54, Mark I.

Existing Mark I. fuzes will be altered to conform, as far as possible, to the Mark II. pattern, and when so altered, they will be described as Mark I.*, and will be so stamped. A pattern, Mark I.*, fuze has been sealed to govern the alterations.

All Mark I. fuzes will be returned to Woolwich for conversion as soon as a supply of either Mark I.* or Mark II. shall have been received to replace them.

Officers concerned should at once put forward demands.

Fuze, time, sensitive, long, No. 23.

Obsolete.

The "Fuze, time, sensitive, long, No. 23" (5638), will be regarded as obsolete, and all such fuzes in store will be returned to the Principal Ordnance Officer, Royal Arsenal.

Those in Royal Artillery charge will be returned to store so soon as they are replaced by a supply of either the Mark I.* or Mark II. "Fuze, time, percussion, middle, No. 54."

4. Fuzes, 4: Fuzes for instruction, percussion, base.
No. trace.

5. Fuzes, 5: Fuze, percussion, D.A., impact, drill
Paragraph 11017: Fuze, drill, percussion, D.A., with cap,
No. 1 (Mark I)

A pattern (design R.L. 11830 (1)) of the above-mentioned drill fuze has been sealed to govern manufacture for land service.

It is made of gunmetal, solid, and to the same external dimensions as the Service fuze.

The body and cap are bronzed, and stamped "DRILL."

A certain number of these drill fuzes have been issued, which have been made from burnt-out service fuzes, but no more will be so made.

Appendix G. Magazine Lamps (from Great Britain, War Office, List of Changes in War Matériel and of Patterns in Military Stores... [London: HMSO, 1874-96], paragraphs as indicated).

[Paragraph 2573]. Lamps, magazine: passage

wall

to light in opposite

directions

Patterns of these lamps have been sealed to govern future supplies.

The passage and wall lamps are of an improved construction.

The candle sockets and holders are interchangeable in these lamps.

Paragraph 3857]. Lamps, magazine, passage, (Mark II)

wall

Patterns of the above mentioned lamps have been sealed to govern future manufacture. They differ from the previous patterns (2573) in having no reflectors, or fittings to receive the same.

Reflectors will be removed from existing lamps.

Paragraph 7252]. Lamps, magazine.

Patterns, of the undermentioned lamps have been sealed to govern future manufacture: -

Lamp, Magazine,	Land	To burn candles; one
wall (Mark III)	Service	large and two small,

Lamp, Magazine, passage (Mark III)	Land Service	glass sides To burn candles; circular glass bottom.
Lamp, magazine, partition (Mark II)	Land Service	To burn candles; to light in opposite directions.
Lamp, magazine, Bermuda Pattern (Mark II)	Land Service	To burn candles; to light in three directions.

The lamps are similar to those mentioned in paragraphs 2573, 3857, and 5617, except that the brass movable candle sockets have been altered in the following particulars, viz:-

1. The cap has been done away with, and a solid head substituted.
2. The curve of the top of the cylinder is flattened, and the hole made larger.
3. The disc under the candle is reduced in diameter.
4. The base of the socket is attached by a joint instead of being screwed.

Paragraph 8462. Lamps, magazine.

Bermuda Pattern (Mark III)

Partition (Mark III)

Passage (Mark IV)

Wall (Mark IV)

Patterns of the above-mentioned magazine lamps have been sealed to govern future manufacture and alteration of existing store.

They differ from the previous patterns, 7252, in the following particulars, viz:-

The brass movable candle sockets have been replaced by tin open sockets, supported in the different lamps as follows:-

In the Bermuda, partition, and wall lamp, the socket is fixed to a movable tin tray, which fits into the bottom of the lamp.

In the passage lamp, the socket is attached by wires to a ring resting on the existing ledge round the interior of the lamp.

The ventilation of the partition, passage, and wall lamps has been increased as follows:-

In the partition lamp, the smoke cone has been removed, and six holes have been pierced round the perforated cap. In the passage lamp, the inner smoke cone has been removed, and 12 holes ($1/8$ inch full in diameter) have been drilled through the glass globe, at a height of $1-1/2$ inches from the bottom, and equidistant from one another. In the wall lamp, the inner smoke cone has been removed.

Sockets with false bottoms for the Bermuda, partition, and wall lamps, and suspending sockets for the passage lamps, will be supplied from Woolwich on demand.

The alterations in the ventilation of lamps in use and in store will be carried out locally, but the drills for making the holes in the glass of the passage lamps must be specially hardened.

Appendix H. Plugs (from Great Britain, War Office, List of Changes in War Matériel and of Patterns in Military Stores... [London: HMSO, 1895-1902], paragraphs as indicated).

Plugs, 1: Plugs, base, shell, No. 1.

[Paragraph 8101]. Plug, base, shell, large (Mark I).

A pattern of the above-mentioned plug has been sealed to govern manufacture.

It is made of gunmetal to the same external shape as the "Fuze, percussion, base, large, No. 11," (8099), except that it has a recess to take the "Wrench, base plug" (3529).

The plug is hollow, the cavity being closed with a plate spun over. A lead disc is fitted under the flange to make a watertight joint when the plug is screwed into a shell.

The plug is stamped with the letter "P" on the base.

[Paragraph 11873]. Plugs, base, shell, No. 1 (and other items) 1. In future manufacture of the above mentioned large and medium base fuzes (large no. 11 and medium no. 12), the radius of the heads will be increased so as to give a better bearing to the pins of the "Wrench, opening fuzes"...

The radius of the heads of the large and medium drill fuzes... and Nos. 1 and 2 base plugs... will also, in future manufacture, be similarly increased.

Plugs 2: Plugs, fuze hole, special.

[Paragraph 8631]. Plug, fuze-hole, special, (Mark I)

A pattern (design R.L. 8899) of the above-mentioned plug has been sealed to govern manufacture, for use with projectiles which take nose fuzes, and are filled with lyddite.

The plug is made of gunmetal, with a projecting flange and leather washer below. It is screwed to the G.S. fuze-hole gauge for a length of 1.8 inches, and has a square key hole in the top, the same as the G.S. plug.

Weight about 8 1/2 oz.

Total length (over all) 1.95 in.

Plugs 3: Plug, fuze hole, drill, G.S.

[No trace, 1883-1904.]

Appendix I. The Aiming Rifle (from Great Britain, War Office, List of Changes in War Matériel and of Patterns in Military Stores... [London: HMSO, 1895], paragraph 7856).

Rifle, aiming, Morris, B.L., 1-inch. (Mark I) Land service. With tube 0.23-inch "E", for 6-inch guns and upwards.

The above-mentioned aiming rifle has been approved for land service, for use with B.L. guns of 6-inch calibre and upwards, in imparting instruction in laying.

Drawings have been sealed to govern manufacture as may be ordered.

A complete set of the apparatus consists of the following:-

Rifle, aiming, Morris, B.L., 1-inch -

Barrel, 1-inch	steel, with two washers, collar, set screw, and spiral spring.
----------------	--

Breech-piece	steel (in two parts), with set screw, handle, two heads (one electric and one percussion), two extractor clips, striker, and spiral spring.
--------------	---

Discs, extracting	steel (10 to a set).
-------------------	----------------------

*Frame, expanding	bronze (in two parts), with expanding screw, two washers, and two nuts.
-------------------	---

*Needle	electric	steel with lead, head, spiral spring, and securing nut.
---------	----------	---

percussion	steel with head, spiral spring, and securing nut.
Tube, aiming, 0.23-inch "E"	steel, with washer and securing nut; rifle, aiming, Morris, B.L., 1-inch.

The 1-inch barrel is rifled and chambered in the same manner as the 1-inch Nordenfelt gun (3935, 4921). Fitted to the rear end of the barrel is a steel breech-piece, provided at the front end with a screw thread having three interruptions cut upon it; the interior of the barrel being prepared in similar manner admits of the breech being closed and the breech piece locked in position by the sixth of a turn.

The breech piece is in two parts, secured by a screw thread and set screw, and is furnished on the exterior with a sliding collar provided with two handles to facilitate insertion and withdrawal. The rear portion is furnished with a striker and spiral spring, and the front portion prepared for the reception of two heads (one for electric and one for percussion firing), through the centre of either of which the point of the striker passes. Extracting clips, which engage with the base of the cartridge case, are fitted to the front portion of the breech-piece for extracting the cartridge case when the breech-piece is withdrawn.

Fitted to the exterior of the barrel is a bronze frame, furnished with an expanding screw and nut for securing it in the chamber of the gun. The frame is furnished with a steel feather, which engages with a longitudinal recess on the barrel, and forms a guide for the barrel when in position. A spiral spring (acting as a buffer) and two washers are fitted over the barrel at the rear of expanding frame. A steel collar screwed over the barrel at the muzzle and secured by a set screw forms a stop, and serves to prevent the barrel being withdrawn from the expanding frame when

in the gun.

The rifle is fired by means of the firing mechanism of the gun, for which purpose two steel needles are provided (one for electric and one for percussion firing). The needles (which are furnished with heads similar in form to the vent-sealing tubes used with the guns) are intended to pass through the vent channel of the gun, and make contact with the outer end of the striker. The electric needle differs from that for percussion firing in being insulated and furnished with a lead, which is placed over the terminal of the lock. The needles vary in length to correspond with the length of the vent channel of the gun in which they are intended to be used.

The 0.23-inch aiming tube "E" is of special pattern. It is furnished with brass collars, which fit the bore of the 1-inch barrel, and is secured by a nut and washer at the muzzle.

The following is a list of the implements issued with each rifle:-

Rifle, aiming, Morris, B.L., 1-inch -			
Brush, cleaning	without rod 1
Rod, cleaning	wood 1
Tommy	steel 1
Wrenches breech-piece	steel 1
discs,			
extracting	steel 1
*expanding	steel 1
needle	steel 1
Tube, aiming, 0.23-inch -			
Brush, cleaning	without rod 1
Rod, cleaning	steel 1

Method of fitting and using the apparatus.

The screwed collar is removed from the muzzle end of

the 1-inch barrel, and the spiral spring, washers, and expanding frame placed over the barrel from the muzzle; the screwed collar is then replaced and secured by the set screw. The apparatus is placed in the chamber of the gun in such a position as will admit of the outer end of the breech-piece engaging with the inner end of the axial vent of the gun when the breech is closed. The bronze frame is expanded so as to secure the apparatus in the chamber by turning the expanding screw to the right by means of the wrench provided for the purpose; the axes of the gun and 1-inch barrel will then coincide.

When the breech of the gun is closed, the electric or percussion needle will be placed in the vent channel. The apparatus can then be fired by the firing mechanism of the gun.

Elevation is obtained by means of the gun sights, and any error in line will be corrected by use of the deflection scale.

The 0.23-inch aiming tube E is placed in the 1-inch barrel (from the breech), and secured at the muzzle end by a nut and washer.

Ammunition

1-inch barrel -

When fitted with breech-piece having electric head ...	Cartridge, aiming rifle, 1-inch.
When fitted with breech-piece having percussion head ...	Cartridge, machine gun, Nordenfelt, 1-inch, steel,
0.23-inch aiming tube E ...	Cartridge, aiming tube.

Subsequent alterations to the Morris aiming rifle included the following (from Great Britain, War Office, List of

Changes in the War Matériel and of Patterns in Military Stores... [London: HMSO, 1895-1904], paragraphs as indicated).

8452 Blocks, retaining needle electric and Needle, electric (Mark II) introduced.

8801 Needle, electric (Mark II). Alteration

9442 Needles, percussion introduced.

9843 Use of aiming rifle extended to 5-inch guns.

11273 Anti-fouling cylinders introduced.

12069 Anti-fouling cylinders abolished.

Appendix J. Tubes (from Great Britain, War Office, List of Changes in War Matériel and of Patterns in Military Stores... [London: HMSO, 1892-9], paragraphs as noted).

Tubes 1: Tube, vent-sealing, electric, P
 Paragraph 7204. Tube, Vent-sealing, electric, P (Mark V)
 ... Brass, for guns with percussion locks.
 A pattern of the above-mentioned item has been sealed to govern future manufacture.

It differs from the Mark IV (#6071) in the internal arrangement for sealing the hole in the head, through which the wires pass, in order to prevent gas escape.

The packing is similar to that of Mark IV...

Paragraph 8655. Tubes, vent-sealing:-

Electric P (Marks VI and VII)

Electric V (Mark VII)

Friction V (Mark VI)

Percussion (Mark IV)

Patterns ... of the above-mentioned tubes have been adopted for service, but have not hitherto been published in List of Changes.

They differ generally from previous patterns... in having the mouth closed by a cork plug instead of a brass bulb embedded in sulphur. In addition the terminals of the V electric tube have increased insulation near the head... The terminals of the Mark VII P tube have also increased insulation, which, in this case, extends for a distance of 5 inches from the head of the tube.

Tubes 2: Tube, vent-sealing, percussion.

Paragraph 8655. see above

Paragraph 10091. Tube, vent-sealing, percussion. (Mark V)... Brass

A pattern (design R.L. 10202n (1)) of the above-mentioned tube has been sealed to govern future manufacture.

In general form and dimensions, it is similar to the Mark IV. percussion tube (8655), but differs in the firing arrangement.

The striker, which is held by a copper shearing wire, is provided with a needle point, and, instead of the cap and anvil, a detonator is held underneath the head of the tube by means of a brass screwed collar, which is retained in position by a copper washer at its base. A disc of fine white paper is placed over the copper washer. The tubes are filled with R.L.G.² powder, the interstices being filled up with R.F.G.² powder (except those filled on or before 14th December 1899, which are filled with pistol powder). They are closed in the same manner as the Mark IV.

Packing

The tubes are packed 10 in a tin box.

Tubes 3: Tube, friction, drill

No Trace, 1883-1904.

Tubes 4: Tube, 0.23-inch, "E"

See Appendix 9

Abbreviations Used

AA	Anti-Aircraft
AP	Armour Piercing
BC	Battery Command
BL	Breech Loading
BLC	Breech Loading Converted
CS	Cast Steel
DRF	Depression Range Finder
FC	Fine grain (powder)
FRH	Fort Rodd Hill
GOC	General Officer Commanding
HC	Hydro-pneumatic
MD	either Military (or Militia) District or modified cordite
PF	Position Finder
QF	Quick-fire
QFC	Quick-fire converted
RCA	Royal Canadian Artillery
RFG	Rifled fine grain (powder)
RGA	Royal Garrison Artillery
SAA	Small arms ammunition

Endnotes

Introduction

- 1 Great Britain, Public Record Office (hereafter cited as PRO), WO32, Vol. 6171, "Report of the Committee appointed to consider the recommendations contained in the Trerasury letter dated 7th April 1880 on the Subject of the Serious Accumulation of Papers of the Records Office," 1 Aug. 1881.
- 2 Ibid. In fact, the recommended retention-home for Engineer papers relevant to Rodd Hill was as follows:
 - Preparation of annual estimates. 5 years
 - Reports of saving and deficiencies. 5 years
 - Demands for stores. 5 years
 - Proposals for erection of new buildings. 5 years
 - Selection of sites. To be kept
 - Contracts. 10 years
 - Repairs. 5 years
 - Appropriation of barracks. 5 years
 - Rates, taxes, etc. 3 years
 - Water and gas supply. To be kept
 - Lands (Purchase, sale, etc.). To be kept
 - Perambulation reports. 3 years
 - Record plans. 3 years
 - Statements of Property. 3 years
 - Engineer establishment (appointments, etc.). 5 years
after the decease of the individual concerned.
 - Charge pay. To be kept.
 - Letter boxes. To be examined after 10 years

Progress reports, fortification. 5-10 years
 Annual estimates, fortification. 10 years [Ibid,
 Appendix A].

- 3 Canada. Public Archives (hereafter cited as PAC), National Map Collection, H4/650, Esquimalt, 1893, Map of Lower Battery; H4/650, Esquimalt, 1897, Plan of Casemate Barracks; H4/650, Esquimalt, 1903; Record Plans Nos. 2 and 3 of Upper Battery and Nos. 2, 3 and 4 of Lower Battery; PRO, WO78/3938, Record Plan No. 1 of Lower Battery and No. 1 of Upper Battery; Fort Rodd Hill National Historic Park, Plan Collection [hereafter cited as FRH, Plans], Outline Plan of Upper Battery, 1900; Outline Plan of Lower Battery, 1900.

The Evolution of the British Coast Fort

- 1 Andrew Noble, Artillery and Explosives. Essays and Lectures Written and Delivered at Various Times (London: John Murray, 1906), pp. 499-500.
- 2 Ibid., p. 500.
- 3 See Great Britain. Army. Corps of Royal Engineers, Papers on Subjects Connected with the Duties of the Corps of Royal Engineers (hereafter cited as Professional Papers), (London and Woolwich: J. Weale, 1836-50) and ibid., new series, 1851-76. For individual entries, see following footnotes.
- 4 John Fox Burgoyne, "Coast Defences, Chiefly as Applicable to the Coast of Great Britain," Professional Papers, n.s., Vol. I, pp. 1-11, and "On Coast Defence" in ibid., Vol. VI, pp. 115-8.
- 5 John Fox Burgoyne, "Memorandum of the Increased Power of Breeching to be Obtained by the Use of Rifled Ordnance," in ibid., n.s., Vol. X, pp. 1-7.
- 6 John Fox Burgoyne, "On Coast Defences" in ibid., n.s.,

- Vol. VI, pp. 115-8.
- 7 Ian Hogg, Coast Defences of England and Wales, 1856-1956 (Newton Abbot: David and Charles, 1974), (hereafter cited as Hogg, Coast Defences), pp. 19-26.
 - 8 Ibid.
 - 9 John Batchelor and Ian Hogg, Artillery (Ballantine Books: New York, 1972), pp. 9-10.
 - 10 Ibid., p. 10.
 - 11 Ibid., pp. 13, 52.
 - 12 Hogg, Coast Defences, pp. 61-2.
 - 13 E.g. Fort Clarence in Halifax.
 - 14 J. Batchelor and I. Hogg, op. cit., p. 11.
 - 15 W. Anderson, "Hydro-Pneumatic Gear for Siege and Heavy Ordnance," Professional Papers, Occasional Papers, Volume X, 1884, pp. 233-74.
 - 16 Hogg, Coast Defences, p. 77.
 - 17 Great Britain. War Office, Treatise in Military Carriages (London: HMSO, 1888), passim.
 - 18 Siegfried Breyer, Battleships and Battle Cruisers, 1905-1907, trans. Alfred Kurti (New York: Doubleday, 1973), pp. 23-43.
 - 19 Great Britain. War Office, Text Book of Gun Carriages and Gun Mountings (London: HMSO, 1924), pp. 39-40.
 - 20 Great Britain. War Office. Treatise on Military Carriages (London: HMSO, 1888), passim.
 - 21 Great Britain. War Office, Treatise on Military Carriages (London: HMSO, 1902), passim.

Rodd Hill and the Typical Coast Fort

- 1 Great Britain. Army. Corps of Royal Engineers, Permanent Fortification for English Engineers, by Major J.F. Lewis (Chatam: Royal Engineer Institute, 1890), p. 277.

- 2 Ibid., p. 282.
- 3 Ibid., p. 279.
- 4 Ibid.
- 5 Ibid.
- 6 Great Britain, PRO, CAB 7/4, Third and Final Report of the Royal Commissioners Appointed to Inquire into the Defence of British Possessions and Commerce Abroad, pp. 420-5. "Report on the Defence of British Columbia" by Lt. Col. T.B. Strange, 7 Nov. 1879.
- 7 Ibid., pp. 432-46, "Report of the Defences of Esquimalt and Victoria" by Col. Lovell, 20 Dec. 1879; PRO, WO78, 2311, "Sketch Showing Ground at Rodd Hill."
- 8 Ibid., "Proposed Battery at Rod Hill."
- 9 Ibid., CAB 7/5; pp. 15-18, Report on Esquimalt by Lt. Col. Nugent dated 8 Oct. 1880.
- 10 Ibid., CAB 7/4, Third and Final Report of the Royal Commissioners Appointed to Enquire into the Defence of British Possessions and Commerce Abroad, p. 420; CAB 18/14, Report on the Defences of British Coaling Stations Abroad, p. 244.
- 11 Ibid., WO78, 3938, Col. O'Brien's plans of Rodd Hill, Macaulay, etc.; *ibid.*, CAB 18/14 Report on the Defences of British Coaling Stations Abroad, pp. 244-6.
- 12 Ibid.
- 13 Royal Engineers Journal, Vol. 23, No. 274, 1 Sept. 1893.
- 14 PAC, National Map Collection, H4/650, Esquimalt, 1893, Plan of Two-Gun Battery.

Building Inventory

- 1 PAC, National Map Collection, H4/650, Esquimalt, 1893 "Rodd Hill, Two-Gun Battery..."
- 2 PRO, CAB 18/14, Report of the Defences of British

- Coaling Stations Abroad... pp. 244-6.
- 3 PAC, National Map Collection, H4/650, Esquimalt, 1903, Record Plans Nos. 2 and 3 of Lower Battery.
 - 4 Ibid., Record plans of both batteries give commencement date as 6 September 1895 and completion date as 31 March 1898. The first recorded practice firing is in October 1897, suggesting that the batteries were substantially complete by then. See the Daily Colonist (Victoria) 23 Oct. 1897 and R. Lovatt, "A History of the Royal Marine Artillery Detachment at Esquimalt, 1893-9" (ms. on file at Fort Rodd Hill National Historic Park), pp. 15-6.
 - 5 PAC, National Map Collection, H4/650, Esquimalt, 1903, Record Plans Nos. 2 and 3 of Upper Battery.
 - 6 Ibid. The first indication of the telephone exchange is on Plan H4/650, Esquimalt, 1905, General Site Plan.
 - 7 Canada. Department of National Defence, Directorate of History [hereafter cited as D. Hist], File 169.012 (D20), unpaginated, O.C.R.A. [Esquimalt] to DEO, MD11, 24 Jan. 1924, enclosing "Material required for Skidding Shed and B.C. Post...", n.d. The pencil annotations on the latter leads one to believe that the building was constructed.
 - 8 D. Hist., file 322.016 (D22), Esquimalt Defence Scheme, 1928.
 - 9 FRH, Plans, FRH-6SP-0001-1929. Rodd Hill, General Site Plan.
 - 10 FRH, plan, "Fire Commander's Post."
 - 11 D. Hist., file 169.012 (D20), unpaginated, OCRCASC [Esquimalt] to DEO, MD11, 26 Feb. 1932 and same to same, 28 Feb. 1932.
 - 12 Ibid., GSO, MD11 to DOO, MD11, 4 Jan. 1934 and reply, 5 Jan. 1934.
 - 13 D. Hist. file 322.016 (D11). Fixed Defences, Juan de

Fuca Strait, 1938.

- 14 Ibid., file 322.009 (D767), RCA Inspections, 1927-1938.
- 15 Interview with Mr. Harold Anderson, April, 1977
(hereafter cited as Recollections, Anderson) and
recollections of Mr. J.E. Rippengale (hereafter cited
as Recollections, Rippengale). Neither man is entirely
certain whether or not a PF was ever in the FC post.
Mr. Rippengale thinks he remembers one there, ca. 1938.
Mr. Anderson, who actually slept in the building in
Sept. 1939, cannot remember one.
- 16 Fort Rodd Hill National Historic Park, Photo collection
[hereafter cited as FRH, photo], Negative No. 1342.
- 17 FRH, plans, GSP-0004-1944, Site Plan, 15 Feb. 1944.
- 18 PAC, National Map Collection, H4/650, Esquimalt, 1903,
Record Plans Nos. 2, 3 and 4 of Lower Battery.
- 19 Ibid., Record Plan 3.
- 20 Ibid.
- 21 Ibid., H4/650, Esquimalt, 1893, "Rodd Hill or two-gun
Battery."
- 22 The lean-to is shown in an unnumbered and undated (but
ca. 1936) photograph in the FRH collection. The oil
store was definitely on site by the 1930s
(Recollections, Anderson).
- 23 FRH, plans, GSP-0004-1944, site plan dated 15 Feb.
1944.
- 24 Ibid., GSP-0002-1944, site plan, VLI, 6 June 1944.
- 25 Recollections, Rippengale; physical examination of
casemate.
- 26 FRH, plans, GSP-0002-1944, Site Plan, VLI, 6 June 1944.
- 27 Ibid., GSP-0003-1954, Site plan revised to 14 Sept.
1944.
- 28 Recollections, Rippengale. Mr. Rippengale thinks it
was among the buildings sold off by the army before
giving up the site. Mr. Earl Pallister, now the acting

area superintendent, was part of a work crew employed by the park in 1962. He does not remember the QM stores as being then extant.

- 29 Fort Rodd Hill National Historic Park, Document file [hereafter cited as FRH, file], FRH, 0082, Armament return, 1900. The original source of this document is not known.
- 30 D. Hist., file 112.3 (D1), unpaginated, M60 to DOC, MD11, 23 March 1914 and reply 12 May 1914.
- 31 Recollections, Anderson.
- 32 D. Hist., file 322.009 (D767), RCA Inspections, 1929, 1930.
- 33 Ibid.
- 34 Ibid., RCA Inspections 1927-38.
- 35 Ibid.; Recollections, Rippengale.
- 36 Recollections, Rippengale.
- 37 Recollections, Rippengale and Anderson.
- 38 D. Hist., file 169.009 (D115) Memorandum on Victoria - Esquimalt by Major-General Griebach, 24 March 1942.
- 39 Ibid., file 322.009 (D764), Staff Officer, Artillery, Pacific Command to AA and QMG, Pacific Command, 13 May 1942.
- 40 Ibid., same to same, 3 June 1942.
- 41 Ibid., same to staff officers Signals, 4 June 1942.
- 42 Ibid., OC [Esquimalt Fortress] to HQ Pacific Command, 13 Jan. 1944. This lists VLI as "Abandoned." It had thus been abandoned sometime after Aug. 1943. See following note.
- 43 Ibid., OC [Esquimalt Fortress] to HQ 6th Cdn. Division, 13 Aug. 1943 and reply 15 Aug. 1943.
- 44 Ibid., DGAA tour notes, 7-11 Feb., 1944. Also examination of casemate, 1977.
- 45 FRH, photo, negatives 1345 and 1347.
- 46 D. Hist., file 322.009 (D674), CO, 27th AA Regiment to

OC W011 RCCS, 21 Aug. 1945, correspondence re removal of signal equipment.

- 47 Ibid., file 327.009 (D137), passim.
48 Recollections, Rippengale.

Structural Notes

- 1 Great Britain. War Office, Textbook of Fortification and Military Engineering (London: HMSO, 1893), p. 304.
- 2 Great Britain. Army. Corps of Royal Engineers, Permanent Fortification for English Engineers by Major J.F. Lewis (Chatam: RE Institute, 1890), pp. 253-4.
- 3 Ibid.
- 4 Great Britain. War Office, Textbook of Fortification and Military Engineering (London: HMSO, 1893), p. 304.
- 5 Great Britain. Army. Corps of Royal Engineers, Permanent Fortification for English Engineers by Major J.F. Lewis (Chatam: RE Institute, 1890), p. 256.
- 6 Great Britain. War Office, Textbook of Fortification and Military Engineering (London: HMSO, 1893), p. 305.
- 7 Great Britain. Army. Corps of Royal Engineers, Permanent Fortification for English Engineers by Major J.F. Lewis (Chatam: RE Institute; 1890), p. 258.
- 8 Great Britain. War Office. Textbook of Fortification and Military Engineering (London: HMSO, 1893), pp. 316-7.
- 9 Great Britain. Army. Corps of Royal Engineers, Permanent Fortification for English Engineers (Chatam: RE Institute, 1890), p. 297.
- 10 Ibid., p. 133.
- 11 Ibid., pp. 169-70.
- 12 Ibid., p. 176.
- 13 Ibid., pp. 177-8.
- 14 PAC, National Map Collection, H4/250 - Halifax, 1901

- (Fort Ogilvie), H4/250 - Halifax, 1901 (Fort Cambridge).
- 15 For Macaulay, see Ibid., H4/650 - Esquimalt - 1902. Record Plans of Macaulay.
 - 16 Recollections, Anderson and Rippengale.
 - 17 Great Britain. Army. Corps of Royal Engineers, Permanent Fortification for English Engineers by Major J.F. Lewis (Chatam: RE Institute, 1890), pp. 233ff.
 - 18 PAC, National Map Collection. H4/650 - Esquimalt - 1903, Record Plans of Lower Battery.
 - 19 Ibid., H4/650 - Esquimalt - 1897, Accommodation Plan.
 - 20 Great Britain. Army. Corps of Royal Engineers, Permanent Fortification for English Engineers by Major J.F. Lewis (Chatam: RE Institute, 1890), pp. 233ff.
 - 21 PAC, National Map Collection. H4/250 - Halifax, 1901 (Fort Cambridge).
 - 22 D. Hist., file 322.009 (D740) unpaginated. Signal Hill Engineer Services, Contract for roofing building, 1934.
 - 23 PAC, National Map Collection, H4/650 - Esquimalt - 1903, Record Plans of Upper Battery. Also FRH photos. The FRH photo collection has never been properly inventoried so a complete list of historic photos showing the Upper guardhouse is not available at this time.
 - 24 PAC, National Map Collection, H4/650 - Esquimalt - 1903, Record Plans of Lower Battery. Also FRH, photos. See Note 23.
 - 25 Recollections, Anderson.
 - 26 PAC, National Map Collection, H4/650 - Esquimalt - 1903, Record plans of Lower Battery.
 - 27 Ibid.
 - 28 Ibid.

Building Interior Notes

- 1 Great Britain. Army. Corps of Royal Engineers, Permanent Fortifications for English Engineers by Major J.F. Lewis (Chatam: RE Institute, 1890), p. 149.
- 2 Ibid., pp. 146-9.
- 3 Ibid., pp. 144-6.
- 4 Ibid., pp. 142-3.
- 5 PAC, National Map Collection, H4/650 - Esquimalt - 1903, Record Plans of Upper Battery and Lower Battery.
- 6 Great Britain. Army. Corps of Royal Engineers, Permanent Fortification for English Engineers by Major J.F. Lewis (Chatam: RE Institute, 1890), pp. 150-5.
- 7 Ibid., p. 151.
- 8 Ibid.
- 9 Ibid., pp. 151-2.
- 10 PAC, National Map Collection, H4/650 - Esquimalt - 1903, Record Plans of Lower Battery.
- 11 Recollections, Anderson.
- 12 Great Britain. Army. Corps of Royal Engineers, Permanent Fortification for English Engineers by Major J.F. Lewis (Chatam: RE Institute, 1890), pp. 280-1.
- 13 Recollections, Anderson.
- 14 Great Britain. War Office. Textbook of Fortification and Military Engineering (London: HMSO, 1893), p. 316.
- 15 Great Britain. Army. Corps of Royal Engineers, Permanent Fortification for English Engineers by Major J.F. Lewis (Chatam: RE Institute, 1890), p. 289.
- 16 Ibid.
- 17 PAC, National Map Collection. H4/650 - Esquimalt, 1903 (Record Plan 3 of Upper Battery).
- 18 Great Britain. Army. Corps of Royal Engineers, Permanent Fortification for English Engineers by Major J.F. Lewis (Chatam: RE Institute, 1890), p. 291.

- 19 Recollections, Anderson.
- 20 Recollections, Rippengale, Anderson and Betty Estick.

Equipment

- 1 Great Britain. War Office, Regulations for the Equipment of the Regular Army. Part 2. - Section XII (a) Royal Garrison Artillery (London: HMSO, 1904) (hereafter cited as Equipment Regulations, [1904]).
- 2 Great Britain. War Office, Priced Vocabulary of Stores (London: HMSO, 1898) (hereafter cited as Priced Vocabulary [1898]).
- 3 Great Britain. War Office, List of Changes in War Matériel and of Patterns of Military Stores... [title varies] (London: HMSO, 1860 -) (hereafter cited L of C plus the appropriate paragraph no. For the year correspondence of the paragraph numbers, see Table 6.
- 4 Great Britain. War Office, Treatise on Military Carriages and Stores Connected with Them (London: HMSO, 1902) and Handbook for the 6-Inch B.L. and B.L.C. Guns, Mountings. (London: HMSO, 1904).
- 5 D. Hist., file 322.009 (D767), RCA Inspections, 1927-1938.
- 6 L. of C., paragraph 6278.
- 7 Ibid., paragraph 4757.
- 8 Priced Vocabulary (1898), p. 687.
- 9 Great Britain. War Office, Handbook for the 6-Inch B.L. and B.L.C. Guns, Mountings. (London: HMSO, 1904), pp. 7-10.
- 10 Equipment Regulations (1904), pp. 98-9, 148-175.
- 11 L. of C., paragraph 5914.
- 12 Ibid., paragraphs 5912 and 5913; Great Britain. War Office, Handbook for the 6-Inch B.L. and B.L.C. Guns, Mountings. (London: HMSO, 1904), pp. 111-15.

- 13 Priced Vocabulary (1898), p. 397.
- 14 Ibid., pp. 397ff.
- 15 L. of C., paragraph 5912.
- 16 Ibid., paragraph 5914.
- 17 Equipment Regulations (1904), pp. 90-1, 128-9, 140, 154-5, 282-305, 307.
- 18 Ibid., p. 137.
- 19 L. of C., paragraph 7594.
- 20 Ibid., paragraph 11584.
- 21 Ibid., paragraph 5680.
- 22 Ibid., paragraphs 7594, 5680, 11584.
- 23 D. Hist., file 322.009 (D767), RCA Inspection, Esquimalt, 1935.
- 24 L. of C., paragraphs 9770, 11584.
- 25 Recollections, Anderson.
- 26 L. of C., paragraph 7594.
- 27 Ibid., paragraph 11584.
- 28 Ibid., paragraph 5680.
- 29 Equipment Regulations (1904), pp. 138-9.
- 30 FRH file FRH.0078, List of Ammunition, 1902. The Original source of this document is not known.
- 31 D. Hist., file 322.009 (D767), RCA Inspection, Esquimalt, 1935.
- 32 Recollections, Anderson.
- 33 Great Britain. War Office, Handbook for the 6-Inch B.L. and B.L.C. Guns, Mountings. (London: HMSO, 1904), pp. 74-7.
- 34 Recollections, Anderson.
- 35 Recollections; Betty Eastick.
- 36 D. Hist., file 322.009 (D767), RCA Inspection, Esquimalt, 1827.
- 37 Ibid., RCA Inspection, 1929.
- 38 Ibid.
- 39 Equipment Regulations (1904), pp. 130-1, 448-9.

NOTE: From this point onward, all information contained in these endnotes, from three sources only. As at least two are cited for each endnote, it is impossible to use "ibid;" to simplify matters, the remaining endnotes have therefore been put in tabular form. Entries in square brackets in the List of Changes Column are for paragraphs in the 1901 Volume, which the author has never seen (see above, Introduction to Appendices).

	<u>Equipment</u> <u>Regulations</u> (1904), pages	<u>Priced</u> <u>Vocabulary</u> (1898), pages	<u>List of</u> <u>Changes,</u> Paragraphs
40	80-1	113	11662 5378
41	521	549	2184
42	521	549	--
43	80-1	114	--
44	--	844	5640 5740 6895 9053 9234 [10771] [10374] 11976
45	114-5	--	9808
46	114-5	--	[10374]
47	126-7, 140	1024	--
48	110-1	--	--
49	172-3	--	--
50	295	--	--
51	521	801	2715 11626

	<u>Equipment</u> <u>Regulations</u> (1904), pages	<u>Priced</u> <u>Vocabulary</u> (1898), pages	<u>List of</u> <u>Changes,</u> Paragraphs
52	80-1	142	--
53	172-3	640	5142
54	98-9	641	6837
55	114-5	845	2405
56	124-5	941	2326
57	141, 102-3	751	6309
58	80-1	150	--
59	88-9	382	--
60	86-7	309	--
61	433	206	--
62	522	943	--
63	100-1	741	--
64	80-1	144	--
65	102-3	754	6271
66	130-1	1130	8951 10107
67	434	206	--
68	82-3	199	8718
69	130-4	1130	3973 6392 6684
70	21	845	--
71	434-5	994, 1138	--
72	102-3	756	6421
73	102-3	424	5715 10351
74	90-1	424	7676
75	104-5	757	7077 11185
76	120-1	820-1	8947

	<u>Equipment</u> <u>Regulations</u> (1904), pages	<u>Priced</u> <u>Vocabulary</u> (1898), pages	<u>List of</u> <u>Changes,</u> Paragraphs
77	21	--	--
78	123-4	902	8737
79	82-3	210-1	--
80	80-1	146	9885
81	434-5	278	--
82	21	758	8453
83	172-3	642	4872, 4873 7080, 7228
84	172-3	--	--
85	84-5	261	--
86	84-5	262	4774
87	114-5	842	8099, 8652
88	114-5	847	3821, 5216, 8482, 8630
89	114-5	848	5638, 8417, 8912
90	21	--	[10742]
91	21	--	--
92	172-3	--	--
93	434-5	279	--
94	434-5	279	--
95	123-4	--	8735
96	90-1	429	2895
97	82-3	216	--
98	92-3, 140	435	--
99	124-5	877	--
100	522	849	8455
101	522	849	--
102	130-1	1131	5804, 8433
103	84-5, 140	262	4261, 6115,

	<u>Equipment</u> <u>Regulations</u> (1904), pages	<u>Priced</u> <u>Vocabulary</u> (1898), pages	<u>List of</u> <u>Changes,</u> Paragraphs
			6514
104	521	221	7281
105	449	1030	6062, 6587, 8064, [10385]
106	128-9	--	--
107	128-9	1030	--
108	128-9	--	--
109	128-9	1030	6062, 7350, 8064
110	513	950	8381, 9033
111	522	825-6	7252, 8426
112	522	825-6	3857, 7252, 8426
113	513	--	9237, [10414]
114	522	851	2147, 9810
115	116-7	851	6742, 6826, 7049, 7179, 9857
116	433	996	--
117	436-7	1139	--
118	436-7	852	8766
119	520	--	--
120	82-3, 140	223	--
121	126-7	954	8058
122	92-3	449	6352
123	140	279	--
124	436-7	279	--
125	436-7	746, 1140	--
126	433	280	--
127	436-7	280	7718
128	436-7	280	--
129	140	280	--

	<u>Equipment</u> <u>Regulations</u> (1904), pages	<u>Priced</u> <u>Vocabulary</u> (1898), pages	<u>List of</u> <u>Changes,</u> Paragraphs
130	433, 438-9	280	--
131	438-9	280	--
132	82-3	264	7620
133	112-3	909	4472, 9005
134	124-5	912	8101, [10582], 11873
135	124-5	913	8631
136	22	913	--
137	92-3	--	9381
138	438-9	282	--
139	92-3	477	8343, 9026, 12431, 12236
140	104-5	768	4366, 6964
141	104-5	772	4366, 6964
142	31-40	--	--
143	94-5	482	5970, 6705, 6938, 7103, 7274, 7586, 7787, 7859, 8279, 8375, 8862, 9330, [10732], 10999, 11512, 11566
144	23	627	8782
145	23	627	--
146	23	623	7856, 8452, 8801, 9442, 9843, 11273, 12069
147	23	624-5	8452, 8801
148	174-5	723	4595, 6400, 8096, 8727,

	<u>Equipment</u> <u>Regulations</u> (1904), pages	<u>Priced</u> <u>Vocabulary</u> (1898), pages	<u>List of</u> <u>Changes,</u> Paragraphs
			9761
149	104-5	770	5748
150	140	282	--
151	522	957	--
152	107-8	771	6658, 7326
153	522	855	--
154	522	828	--
155	438-9	282	--
156	140	283	--
157	307	--	--
158	82-3	231	--
159	82-3	232	10048
160	522	828	5204
161	107-8	--	4366, 6319, 6964, 9803
162	116-7	856	--
163	108-9	779	--
164	440-1	283	--
165	130-1	1107	--
166	522	829	6612
167	130-1	--	4998, 6578, 11844
168	523	1109	--
169	523	1110	7998
170	96-7	--	6837, 9661
171	174-5	736	6296, 6924, 10144
172	23	19	7880
173	23	19	7880
174	522	829	--

	<u>Equipment</u> <u>Regulations</u> (1904), pages	<u>Priced</u> <u>Vocabulary</u> (1898), pages	<u>List of</u> <u>Changes,</u> Paragraphs
175	140	284	--
176	80-1	--	[10641]
177	174-5	--	--
178	82-3	238	--

Bibliography

Anderson, W.

"Hydro-Pneumatic Gear for Siege and Heavy Ordnance" in Papers Connected with the Duties of the Corps of Royal Engineers, Occasional Papers, Vol. 10 (1884), pp. 233-74.

Batchelor, John and Hogg, Ian V.

Artillery. Ballantine Books, New York, 1972.

Breyer, Siegfried

Battleships and Battle Cruisers, 1905-07. Translated by Alfred Kurti. Doubleday and Company, New York, 1973.

Burgoyne, Sir John Fox

"Coast Defences, Chiefly as Applicable to the Coast of Great Britain" in Papers Connected with the Duties of the Corps of Royal Engineers, n.s., Vol. 1 (1851), pp. 1-11.

"On Coast Defence" in Papers Connected with the Duties of the Corps of Royal Engineers, n.s., Vol. 6 (1857), pp. 115-8.

"Memorandum on the Increased Power of Breaching to be obtained by the Use of Rifled Ordnance" in Papers Connected with the Duties of the Corps of Royal Engineers, n.s., Vol. 10 (1861), pp. 1-7.

Canada. Department of Indian and Northern Affairs. Parks Canada. Fort Rodd Hill National Historic Park Record Centre.

Fort Rodd Hill Photo Collection. Historical photographs of batteries.

Fort Rodd Hill Map Collection. Plans of the batteries.

Fort Rodd Hill Document collection. Documents for which no other source is known, chiefly. Files FRH.0078. List of Ammunition, 1902 and FRH.0082, Armament return, 1900.

Canada. Department of National Defence. Directorate of History.

Papers concerning the history of coast artillery on the west coast, chiefly documents 112.3(D1); 169.009(D115), 169.012(D20), 322.009(D740), 322.009(D767), 322.016(D22), 327.009(D137).

Canada. Public Archives. National Map Collection.

Plans of the Rodd Hill batteries, chiefly in H4/650 - Esquimalt - 1893; H4/650 - Esquimalt - 1897 and H4/650 - Esquimalt - 1903.

Daily Colonist (Victoria)

23 October 1897.

Great Britain. Army. Corps of Royal Engineers.

Permanent Fortification for English Engineers by Major J.F.

Lewis, Royal Engineer Institute, Chatam, 1890.

Royal Engineer Journal

Volume 23, 1893.

Great Britain. Public Record Office.

Cabinet Papers, especially Cab 7/4, Cab 7/5 and Cab 18/14.

War Office Papers, especially WO32, Vol. 6171 and WO28, Maps and Plans of Esquimalt.

Great Britain. War Office.

Handbook for the 6-Inch B.L. and B.L.C. Guns and Mountings, &c. HMSO, London, 1904.

List of Changes in War Matériel and of Patterns of Military Stores... HMSO, London, 1880-1904.

Priced Vocabulary of Stores, HMSO, London, 1898.

Regulations for the Equipment of the Regular Army. Part 2.- Section XII(a). Royal Garrison Artillery. HMSO, London, 1904.

Textbook of Fortification and Military Engineering. HMSO, London, 1893.

Textbook of Gun Carriages and Gun Mountings. HMSO, London, 1924.

Treatise on Military Carriages and the Stores Connected with Them. HMSO, London, 1902.

Treatise on Military Carriages. HMSO, London, 1888.

Hogg, Ian V.

Coast Defences of England and Wales, 1856-1956. Newton Abbott, David and Charles, 1974.

Interviews with Harold Anderson, Betty Eastick, Earl Pallister and J.F. Rippengale.

Lovatt, Ronald

"A History of the Royal Marine Artillery Detachment at Esquimalt, 1893-9." Manuscript on file at the Fort Rodd Hill National Historic Park.

Noble, Andrew

Artillery and Explosives. Essays and Lectures Written and Delivered at Various Times. John Murray, London, 1906.

- 1 The RML Fort (1): Fort Charlotte, Halifax, N.S. The most complicated Canadian example of the polygonal coast fort. It occupies most of an island in Halifax Harbour and is easily the most visible bit of coastal fortification in the city. (Public Archives of Canada.)

HALIFAX, N. S.
FORT CHARLOTTE
PLAN OF MASONRY
AND
DRAINAGE

RECORD PLAN No 3

Notes
 The heights shown are in feet above Mean Water
 Each Station Number — Distance Survey Point
 Size of Ordinary Spring Lines — 6 feet

Capacity of Carriage & Shell Stoves

How	Carriage Stoves	100-115 (544-102 Cartridges)
<u>Upper Battery Carriage Shell Stoves</u>		
12 1/2" Carb. Stove	26	10 Cartridges
5	26	—
5	26	—
6	26	—
<u>Lower Battery Carriage Shell Stoves</u>		
12 1/2" Carb. Stove	17	10 Shell
4	26	—
7	26	—
<u>Upper Battery Carriage Carb. Stoves</u>		
12 1/2" Carb. Stove	12	10 Cartridges
3	26	—
4	26	—
6	26	—
<u>Upper Battery Carriage Shell Stoves</u>		
12 1/2" Shell Stove	180	9 Shell
3	180	—
<u>12 1/2" Shell Stove (Rail Capacity)</u>		
2	180	180

Fort Charlotte

Table of Reference

Constructed prior to 1842. Reconstructed on Standard plan and
 Lower Batteries since 1860-71 at cost of \$1555

Magazine and Carriage Stoves strengthened under Imperial
 Diploma Letter 1860-66 by Captain J. G. M. de la Roche, of a cost of £1000

Particulars of Wall

Depth	50 Feet
Thickness (Internal)	3
Always depth of Water	62
Vertical to Gallies	200

Dimensions of

4	12 1/2" Carb.	Upper Battery
6	6	Lower

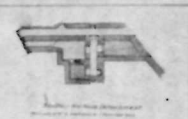

SCALE 20 FEET TO AN INCH
 240

N. C. J. Lamb, Engineer
 Consulting Royal Engineer
 Halifax Nova Scotia
 27 January 1878

- 2 The RML Fort (2): York Redoubt, Halifax, N.S. The large earth traverses between each gun emplacement are typical of RML forts of the late 1860s. (National Historic Parks and Sites Branch.)



- 3 The RML Fort (3): Fort Ives, Halifax, N.S. In this view, two RML embrasures are viewed from outside the fort. Note both the massive iron shields protecting guns and gunners and the pallisade. Viewed from the other side, the RML emplacements would have resembled those at York Redoubt. (National Historic Parks and Sites Branch.)

EMPLOYMENT FOR 64 Pr. S.M.L. GUY

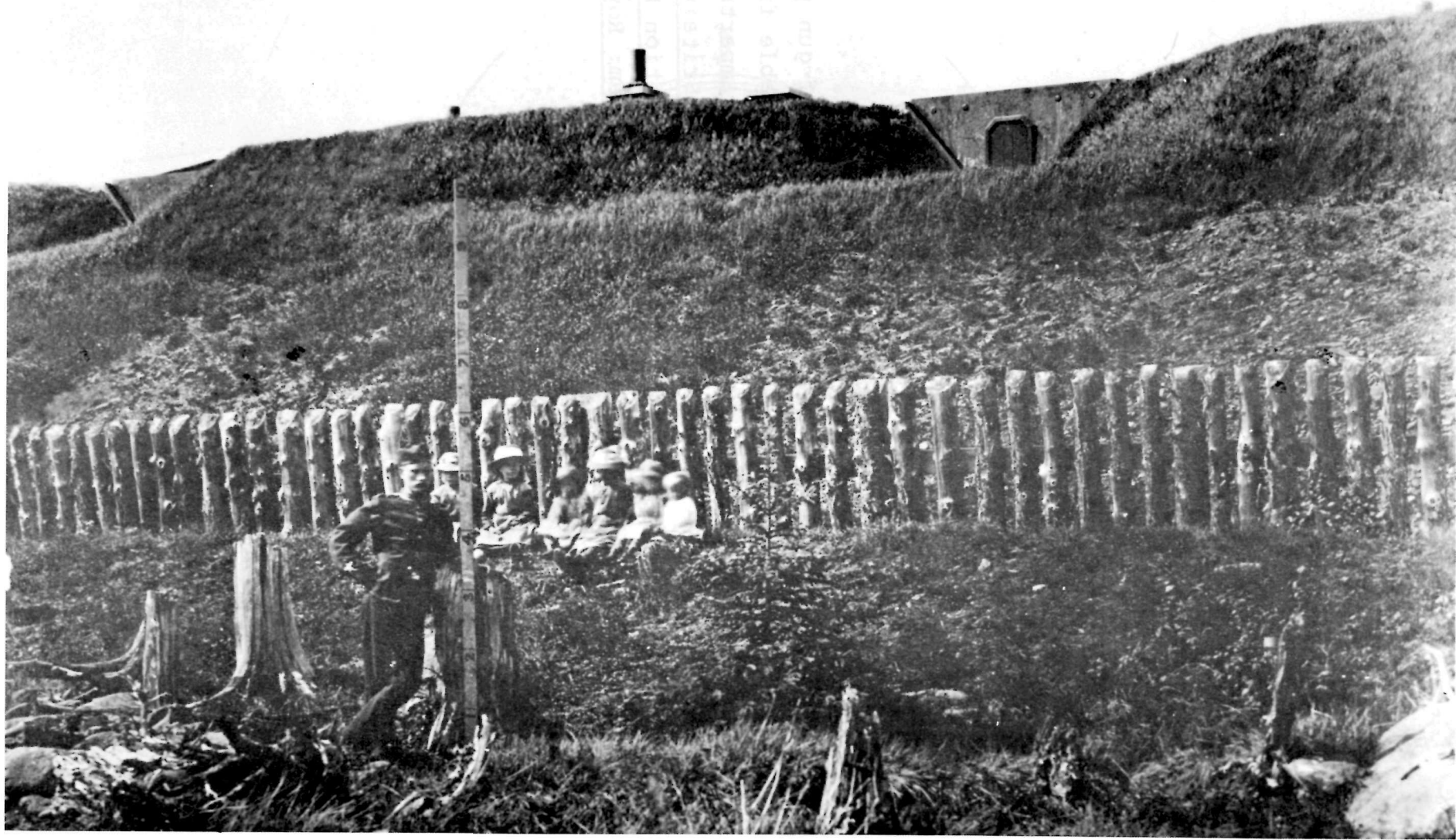

- 4 The RML Fort in transition (1): The Moncrieff gun pit. The pit itself is, in plan, almost indistinguishable from later BL emplacements. The use of traverses and ramparts belong to an earlier era (compare Fig. 5). (Great Britain, Army, Corps of Royal Engineers, Permanent Fortification For English Engineers by Major J.F. Lewis [Chatham: Royal Engineer Institute, 1890], Plate IX.)

EMPLACEMENT FOR 64 Pr. R.M.L. GUN
ON COUNTERWEIGHT CARRIAGE.

PLATE IX.

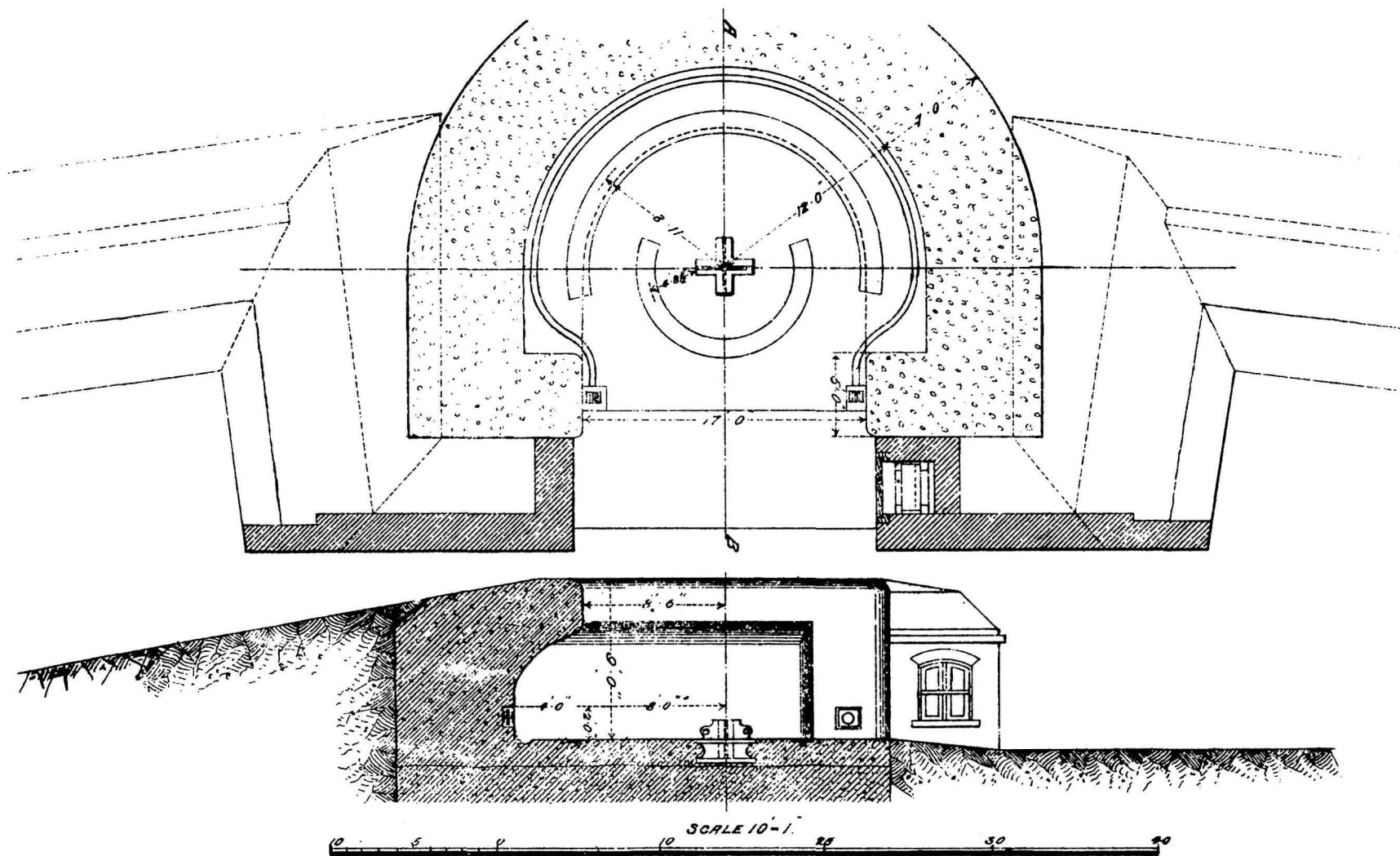

- 5 The RML Fort in transition (2): Cambridge Battery, Halifax, N.S. Cambridge underwent a conversion from RMLs to BLs on barbette carriages in the late 1890s. Almost the whole history of the British coast fort is illustrated in this plan showing the conversion. In outline, the fort resembles the barbette batteries of the smoothbore era. The complicated embrasures of the RML era contrast with the two 6-inch emplacements superimposed over what had originally been the centre and left faces of the RML fort. (Public Archives of Canada.)

Halifax N. S. Cambridge Battery.

Proposed Revision for 2 - 6" B.L. Mark VII Guns.

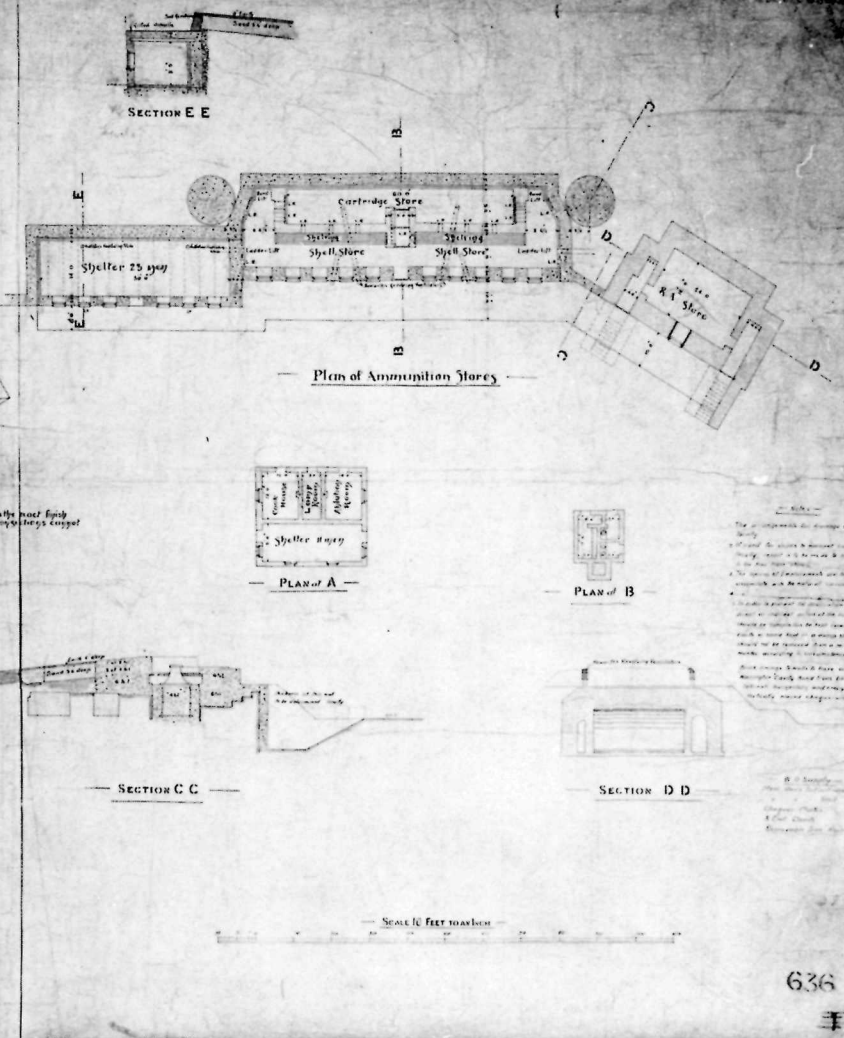
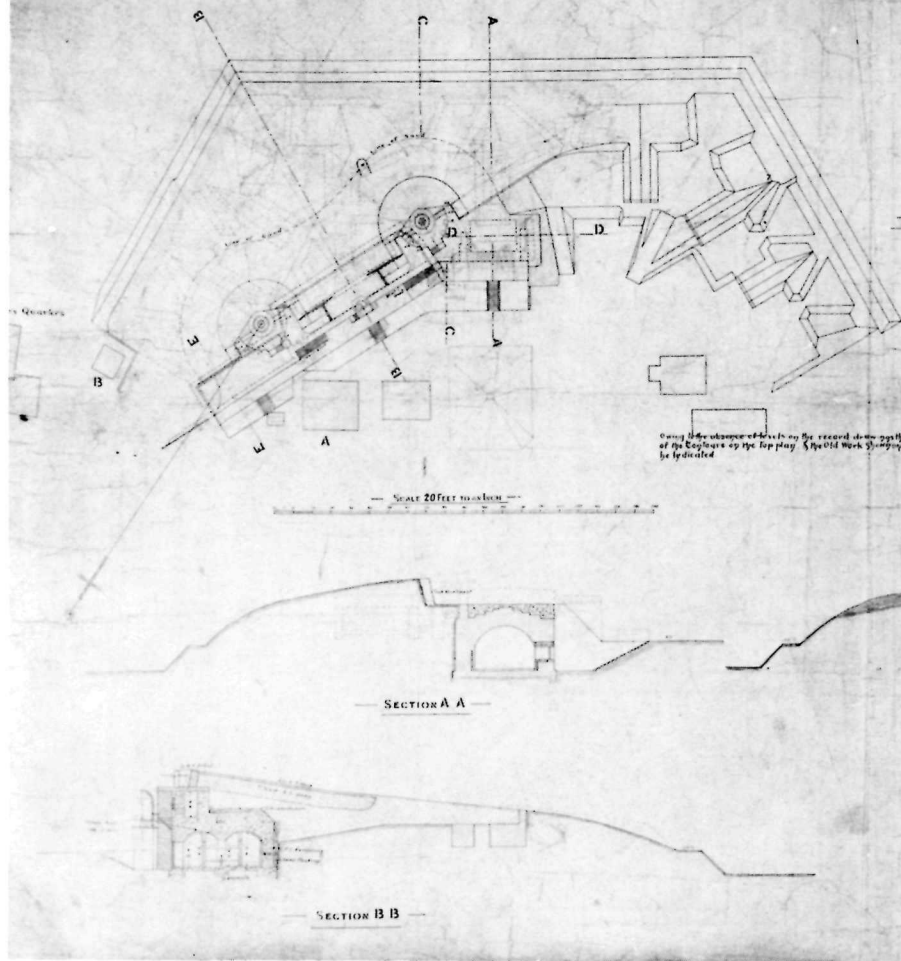

- 6 Rodd Hill. The earliest surviving plan of Lower Battery (1893). The battery was constructed as here shown, the deviations from this plan being minor. (Public Archives of Canada.)

ESQUIMALT
RODD HILL TWO-GUN BATTERY
MAGAZINE & EMPLACEMENT & C.-PLAN &
SECTIONS

51,139

- Structures —
- 1. Battery walls and parapets
 - 2. Magazine walls and floor
 - 3. Gun emplacements and gun pits
 - 4. Gun pits
 - 5. Gun pits with gun barrels
 - 6. Gun pits with gun barrels and gun pits
 - 7. Gun pits with gun barrels and gun pits

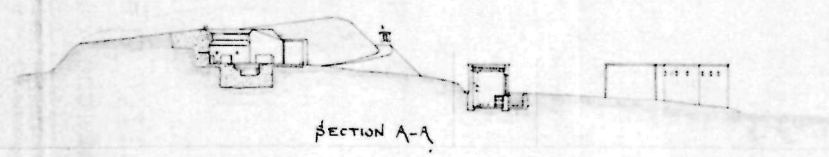
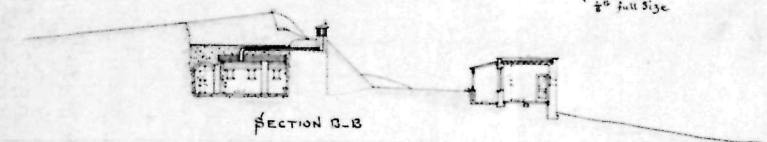
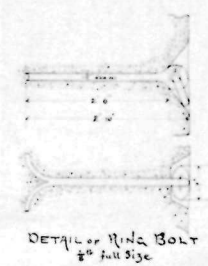
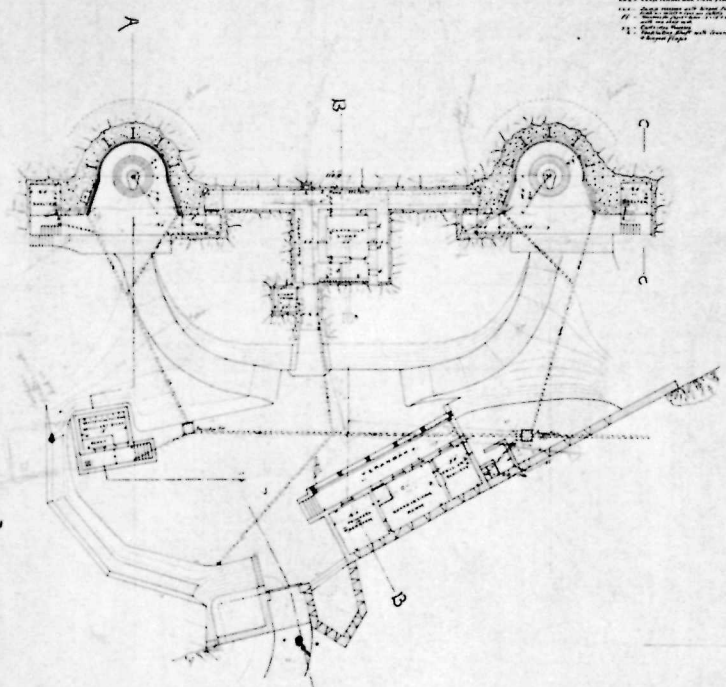

SCALE 10 FEET TO 1 INCH

PLANS, SECTIONS,
PROFILES, & CONNECTIONS
OF THE BATTERY

- 7 Rodd Hill. The casemate barracks (1897). One of the few plans of the casemates. It is not certain if this was drawn before, during or after construction. (Public Archives of Canada.)

ESQUIMALT DEFENCES
TWO GUN & ONE GUN BATTERIES RODD HILL
PROPOSED ACCOMMODATION OF GARRISON
DETAIL PLAN.

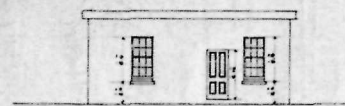
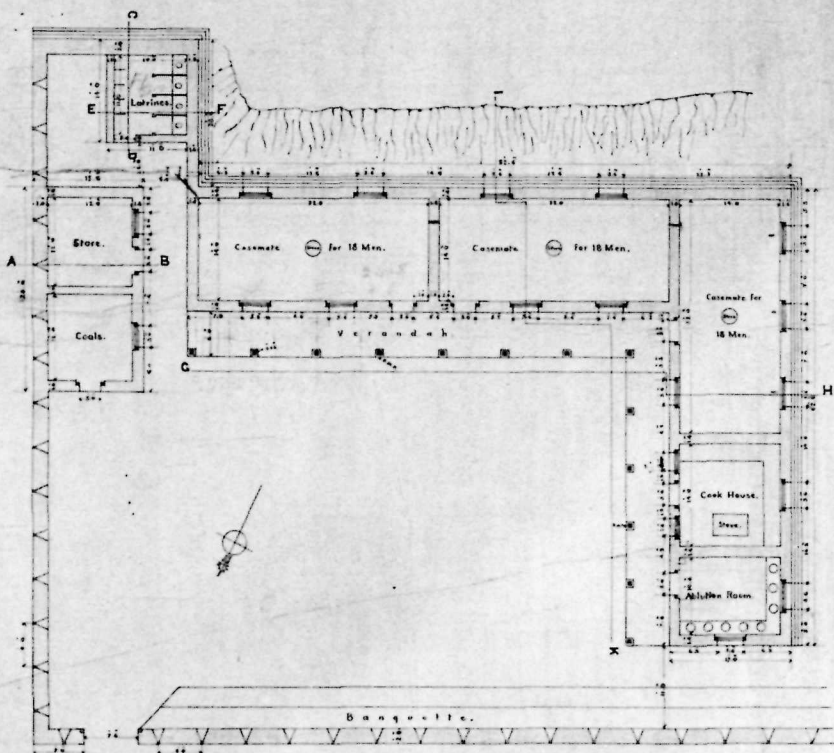

ELEVATION OF 'COALS & STORE'

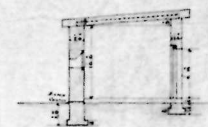

SECTION ON LINE A B

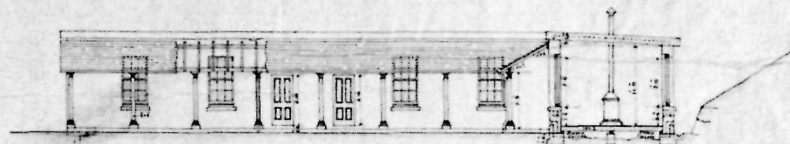

ELEVATION OF CASEMATES ON LINE C.H.

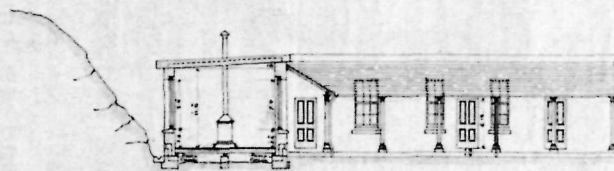

ELEVATION OF COOK HOUSE ETC ON LINE I.K.

LATRINES.

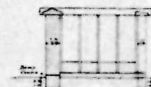

SECTION ON LINE C.D.



SECTION ON LINE E.F.

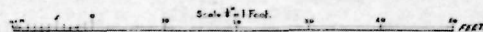

Scale 1" = 1 Foot.

(old plan ref. 209 of 7th. 11)

ACCOMMODATION for GARRISON.
 RODD HILL
 ESQUIMALT B.C.

VICTORIA DRAWING TRACING NO 11
VANCOUVER DR TRACING NO

10
 A. L. Macleod
 2/19
 5/8/92
 131

Drawn by
 J. G. Thomson
 2.1.97.

- 8 Upper Battery: Record Plan 2 (1903). Record Plan 1 is an Admiralty chart altered to show the arc of fire of the Upper Battery gun and is thus useless for the purposes of this report. This plan, and the one following, are the two best sources for Upper Battery. (Public Archives of Canada.)

VICTORIA, B.C. ESQUIMALT DISTRICT, _____
 RODD HILL, UPPER OR ONE GUN BATTERY, _____ RECORD PLANS OF, _____
 EMPLACEMENT FOR ONE 6" B.L. GUN ON H.P. DISAPPEARING CARRIAGE. _____

DRAWING N° 2 (of III).
 RECORD PLAN - 2.

SCALE 10 FEET TO ONE INCH. (R.F. 1/120).

GUN MARK VI, CARRIAGE MARK IV. _____

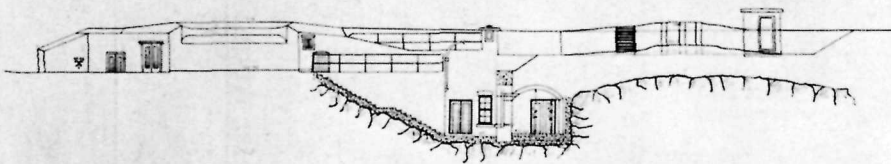
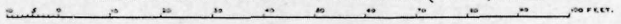

SECTIONAL ELEVATION ON LINE A.B.

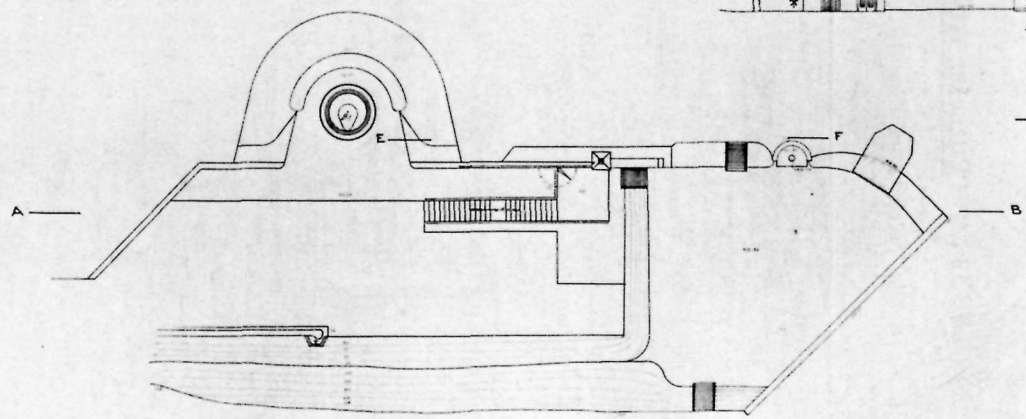

TOP PLAN.

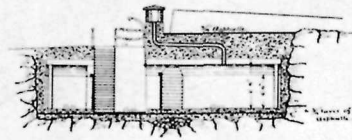

SECTION ON LINE C.D.

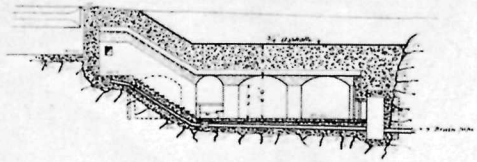

SECTION ON LINE E.F.

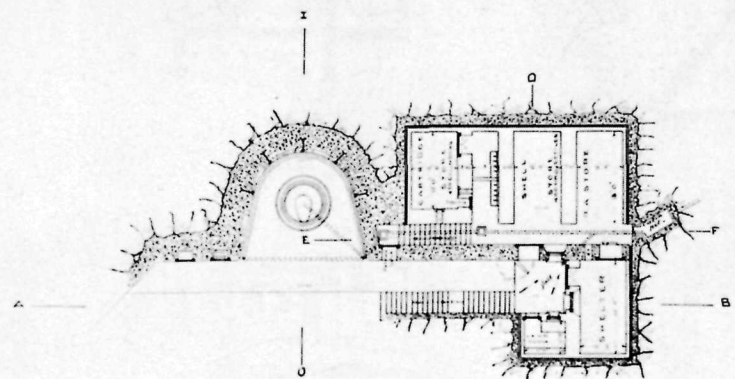

TERREPLEIN PLAN.

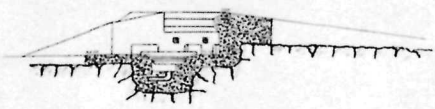

SECTION ON LINE C.H.

A. Grant

LT: COLONEL _____
 OC, R.E. ESQUIMALT, _____

Drawn by
 Geo. Fontaine, S.C. A.C.
 25th June 1903

ESQUIMALT DISTRICT, B.C. DISTRICT, _____
 11th DISTRICT, _____
 VANCOUVER DISTRICT, _____
 1903.

VICTORIA DISTRICT	17	TRACING N°	13
VANCOUVER DISTRICT		TRACING N°	

9 Upper Battery. Record Plan 3 (1903). (Public Archives of
Canada.)

VICTORIA, B.C. ESQUIMALT DISTRICT, —
 RODD HILL, UPPER OR ONE GUN BATTERY, — RECORD PLANS OF, —
 EMPLACEMENT FOR ONE 6 INCH B.L. GUN ON H.P. DISAPPEARING CARRIAGE. —
 DETAILS OF GUARD HOUSE, AND GENERAL SURFACE PLAN. — CUN MARK VI CARRIAGE MARK IV. —

— DETAILS 10 FEET TO ONE INCH (R.F. $\frac{1}{100}$) —
 SURFACE PLAN 30 FEET TO ONE INCH (R.F. $\frac{1}{300}$).

AUTHORITY FOR COMMENCEMENT OF WORK, Sept 22-4-95.
 DATE OF COMMENCEMENT, Do: 8-9-95.
 DATE OF COMPLETION, Do: 3-3-98.
 ESTIMATED COST, Do: \$3508.
 ACTUAL COST, Do: \$3465.

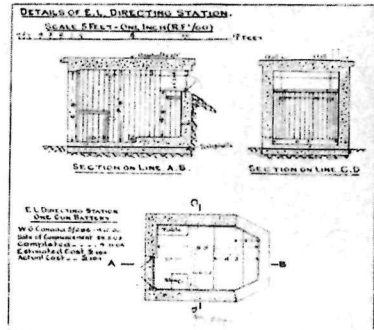
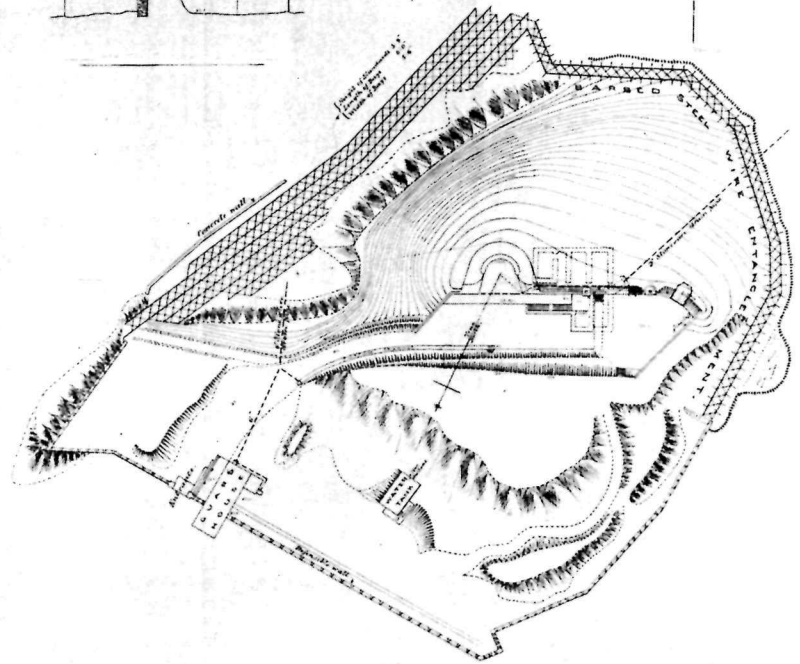
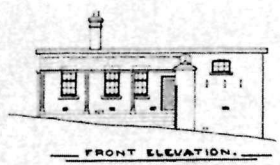
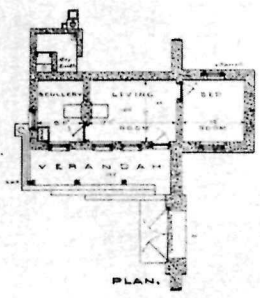
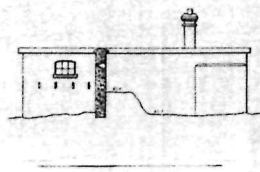
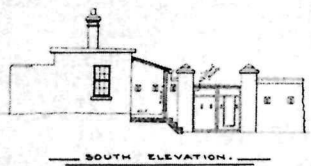

Issued by
 The Engineer, C.E.
 20th June 1900.

SOURCE PLAN AND ELEVATION OF BATTERY
 RODD HILL.

A. Grant.
 LT. COLONEL,
 O.C.R.E. ESQUIMALT,
 1900.

- 10 Lower Battery: Record Plan 2 (1903). This, and the two following, are the best plans of Lower Battery. Record Plan 1 is an altered Admiralty chart. (Public Archives of Canada.)

VICTORIA, B.C. ESQUIMALT DISTRICT, _____
 ROSS HILL, LOWER OR TWO GUN BATTERY — RECORD PLANS OF _____
 EMPLACEMENT FOR TWO 6 INCH GUNS ON H.P. DISAPPEARING CARRIAGES. —

DRAWING N° 2 (of IV).
 RECORD PLAN - 2

SCALE 10 FEET TO ONE INCH (R.F. 1/120).

GUNS MARK VI CARRIAGES MARK IV.

DATE OF AUTHORITY TO COMMENCE W.O. CANADA / 5/1857, OF 22-4-95.
 DATE OF COMMENCEMENT 6-9-95.
 DATE OF COMPLETION 31-3-98.
 ESTIMATED COST £4296.
 ACTUAL COST £4419.

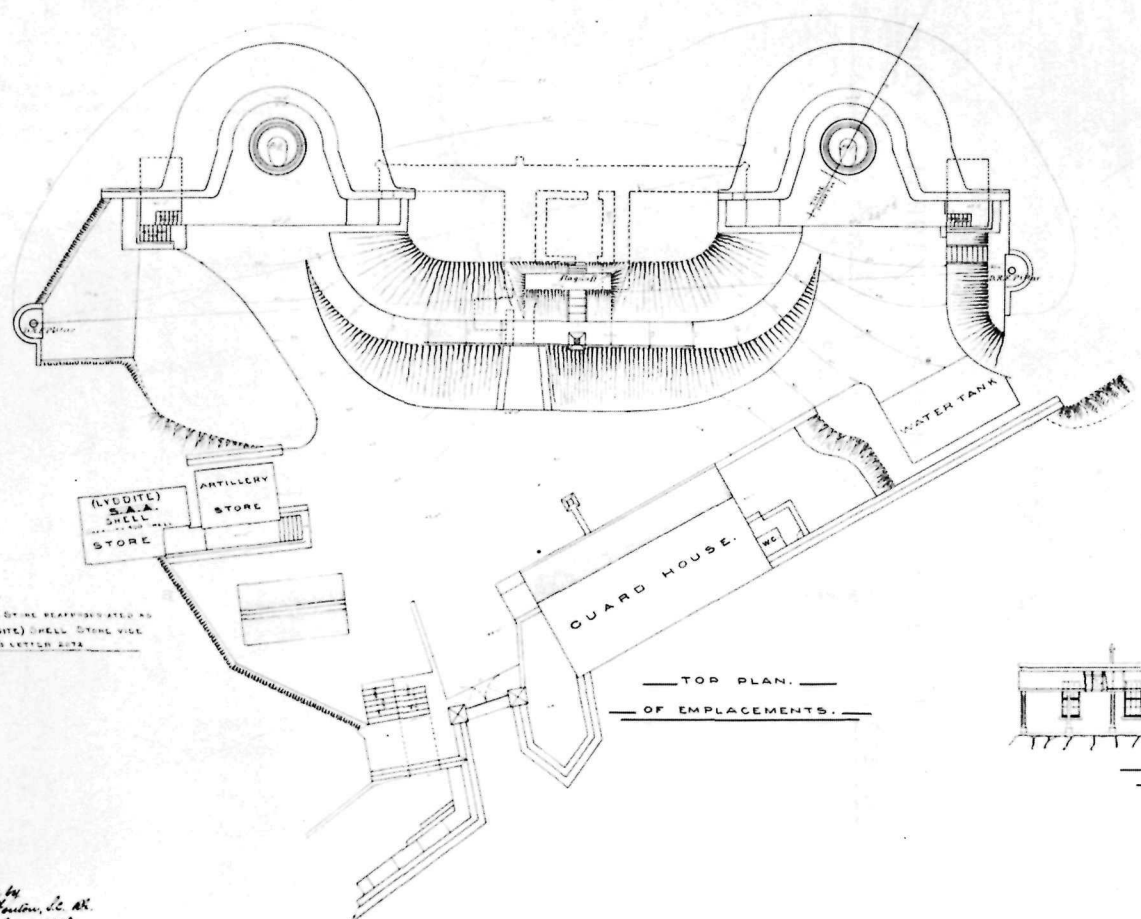

TOP PLAN OF EMPLACEMENTS.

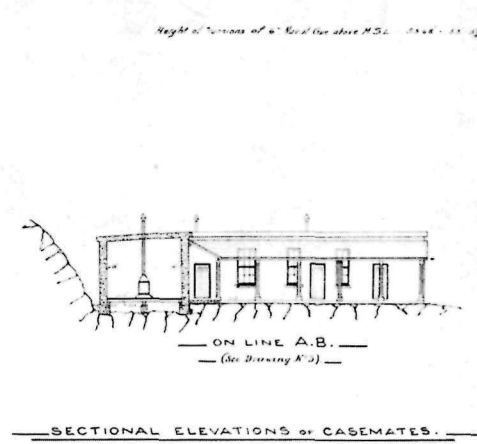

SECTIONAL ELEVATIONS OF CASEMATES.

NOTE:
 S.A.A. BY ME REAFFIRMATED AS
 (LYDDITE) SHELL STORE VILL
 G.E. IS LATTER DATE

Drawn by
 Geo. Fowler, L.C. A.R.
 12th June 1903.

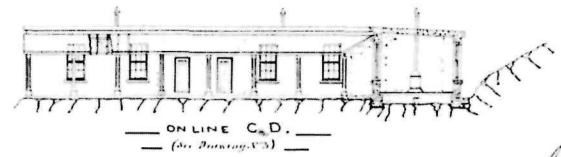

ON LINE C.D. (See Drawing N° 3)

EMPLACEMENTS & CASEMATES
 Ross Hill Battery
 Ross Hill

A. Grant.
 LT COLONEL.
 O.C. THE ESQUIMALT.
 27th August 1903.

APPROVED BY	DATE
APPROVED BY	DATE

- 11 Lower Battery: Record Plan 3 (1903). (Public Archives of Canada.)

VICTORIA, B.C., ESQUIMALT DISTRICT, —
 ROSS HILL, LOWER OR TWO GUN BATTERY, — RECORD PLANS OF. —
 EMPLACEMENT FOR TWO 6 INCH GUNS ON H.P. DISAPPEARING CARRIAGES.

DRAWING N° 3 (OF IV).
 RECORD PLAN-3.

SCALE 10 FEET TO ONE INCH (R.F. 1/40).

NOTE.

S.A.A. STORE REAPPROPRIATED AS
 (LYDITE) SHELL STORE VIDE C.R.E.'S LETTER N° 2072.

CASEMATES.

CUBIC SPACE PER MAN 658 CUB. FT. } NORMAL.
 FLOOR DO. DO. DO. 56 SQ. FT. }

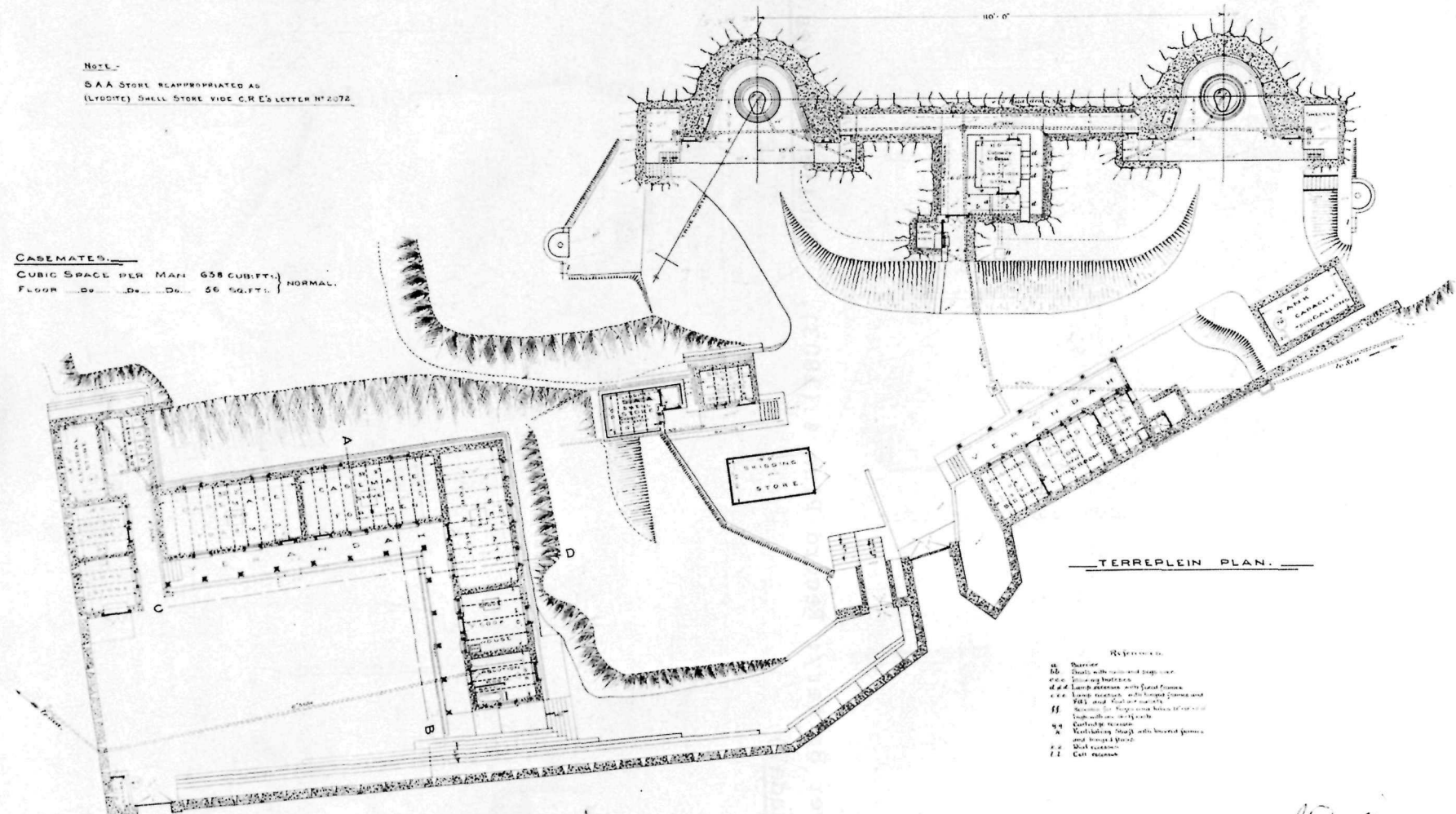

TERREPLEIN PLAN.

- REMARKS.
- 16. Barrier
 - 17. Shell with iron and copper case
 - 18. Shipping store
 - 19. Large structure with fixed frame
 - 20. Large structure with fixed frame and shell and steel in front
 - 21. Structure for magazines below the surface
 - 22. Shell with iron and copper case
 - 23. Disappearing carriage
 - 24. Structure through with lowered frame and bronze band
 - 25. Shell magazine
 - 26. Shell magazine

NOTE, IN WAR TIME THE ACCOMMODATION OF EACH CASEMATE CAN BE INCREASED, BY MEANS OF HAMMOCKS, TO 16 MEN WITH STOVE, 13 MEN WITHOUT.

ALL ALTITUDES ARE GIVEN IN FEET ABOVE M.S.L. AT ESQUIMALT, B.C.

H. Grant
 LT: COLONEL,
 O.C. R.E. ESQUIMALT.
H. Grant 1905.

Drawn by
 Wm. H. Mc R. C.
 24 June 1905

EMPLACEMENT & CASEMATES
 OF LOWER OR TWO GUN BATTERY
 AT ROSS HILL,
 ESQUIMALT DISTRICT,
 VICTORIA, B.C.

VICTORIA DISTRICT	17	TRANS. 100	12
ESQUIMALT DISTRICT		TRANS. 100	12

12 Lower Battery: Record Plan 4 (1903). (Public Archives of
Canada.)

VICTORIA B.C. ESQUIMALT DISTRICT, _____
 RODD HILL, LOWER OR TWO GUN BATTERY, _____ RECORD PLANS OF _____
 EMPLACEMENT FOR TWO 6 INCH GUNS ON H.P. DISAPPEARING CARRIAGES. _____

DRAWING N° 4 (OF IV).
 RECORD PLAN #

SCALE OF SECTIONS 10 FEET TO ONE INCH (R.F. 1/30)

SCALE OF PLAN 30 FEET TO ONE INCH (R.F. 1/360)

NOTE:
 S.A.A. STONE REAPPROPRIATED AS
 (LYDDITE) SHELL STONE VIDE C.P.E.S. LETTERS 2200

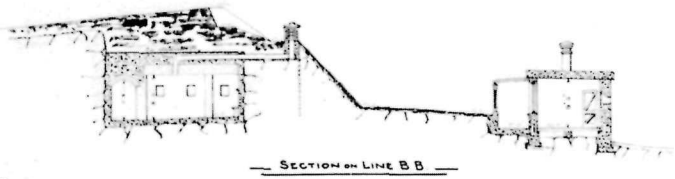
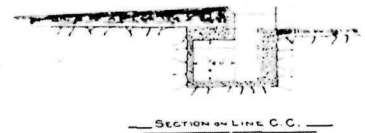
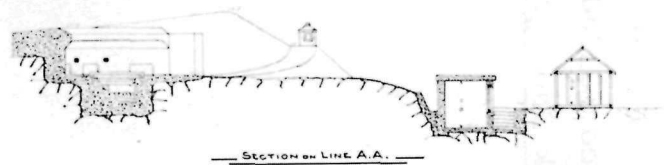
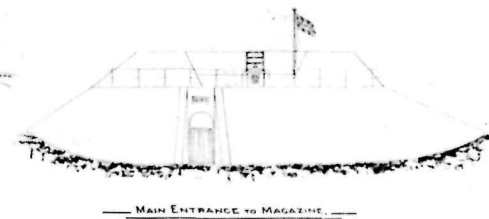
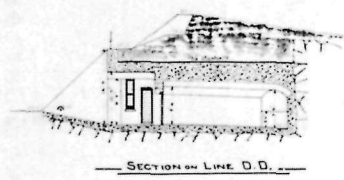
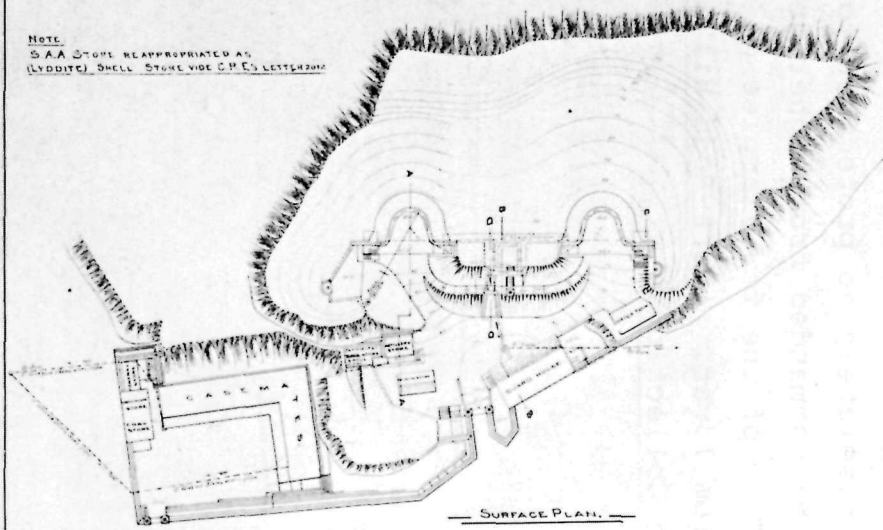

Drawn by
 Geo. Johnston, P.C. A.E.
 17 June 1903

H. Grant
 LIEUT. COLONEL, _____
 O.C.R.E. ESQUIMALT, _____
 27th August 1903.

APPROVED BY	DATE

- 13 Lower Battery around 1930. The design of Lower Battery, while perfectly adequate on paper, is quite awkward in reality. Note how the loopholed defensive wall in the rear of the battery provides absolutely no protection for the gunners. All forts can be commanded from higher ground: Lower Rodd Hill must be one of the few examples of a fort that can be commanded from lower. (Fort Rodd Hill National Historic Park Photograph Collection.)

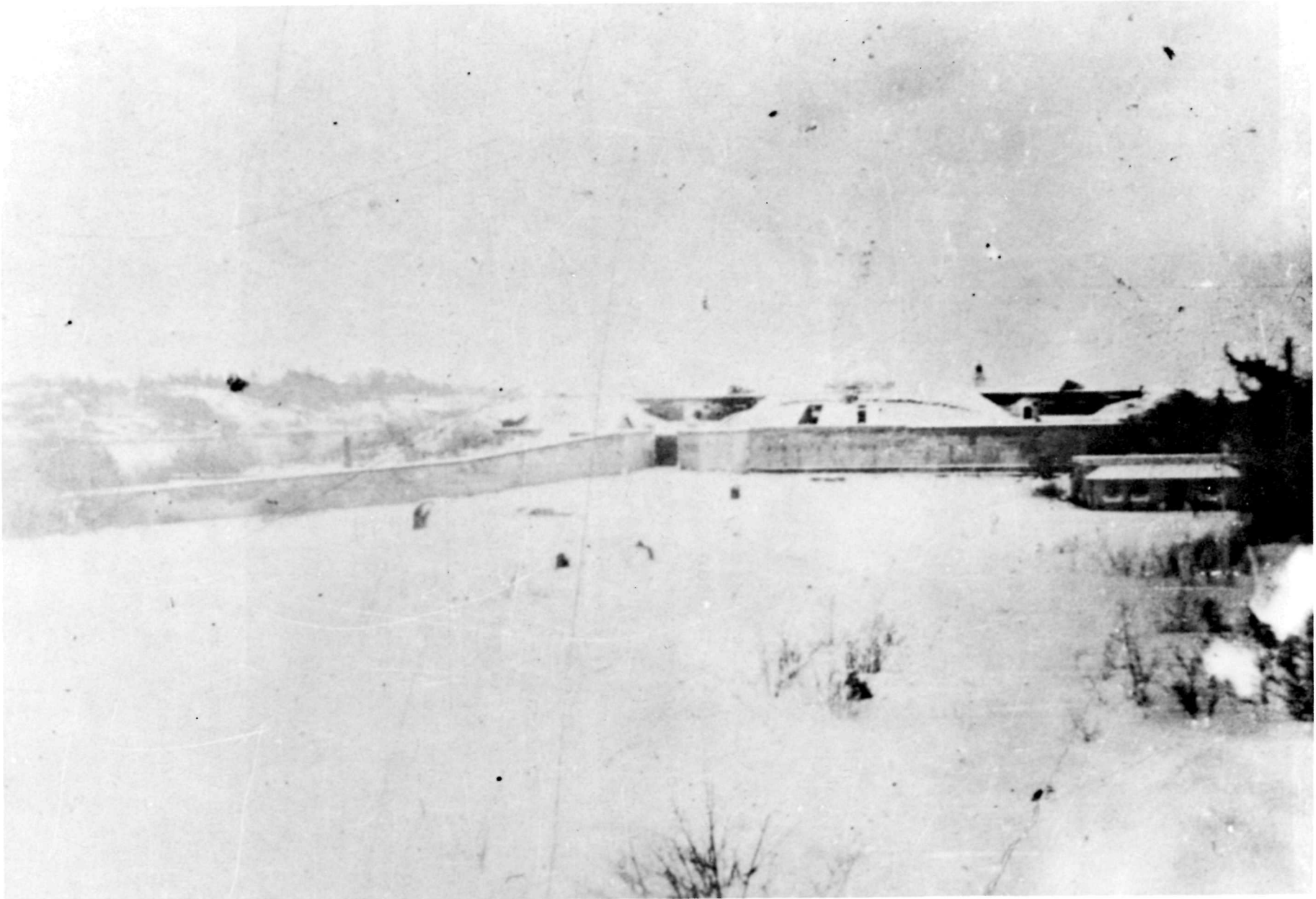

- 14 Rodd Hill from the air, October 1940. By the time this photograph was taken, the first of the temporary buildings erected on the site during the Second World War had been built. Within the batteries themselves, however, there were few changes. The troublesome unidentified structure in Upper Battery is visible to the left of the gun emplacement. It appears, from this photograph, that the 6-inch disappearing gun in Upper Battery might still have been in place. (Fort Rodd Hill National Historic Park Photograph Collection.)

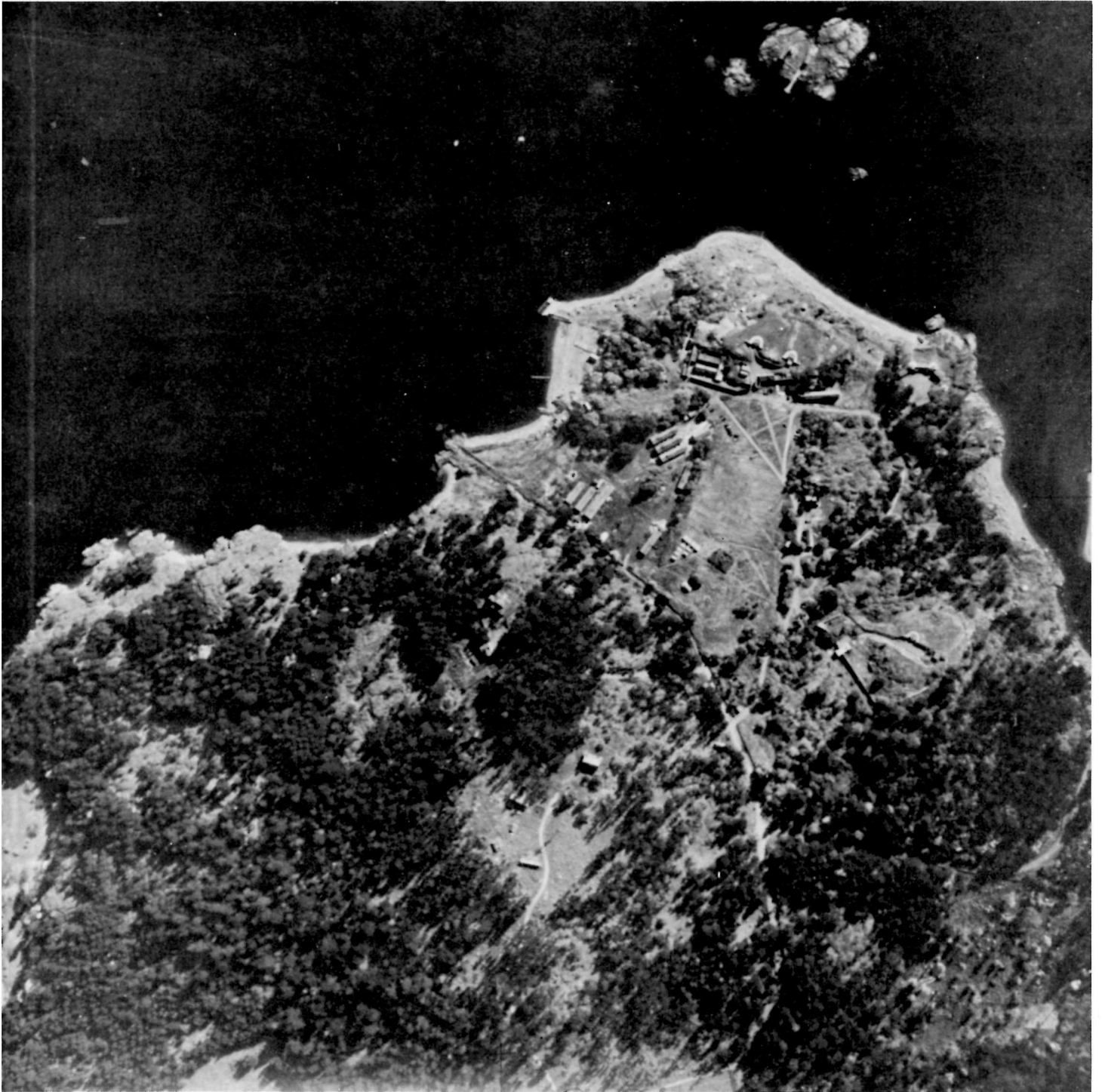

- 15 Lower Battery from the air, 1943. The wartime buildings within the battery are clearly visible in this photograph. Note especially the 40 mm Bofors gun in the emplacement and the associated structures surrounding it. (Fort Rodd Hill National Historic Park Photograph Collection.)

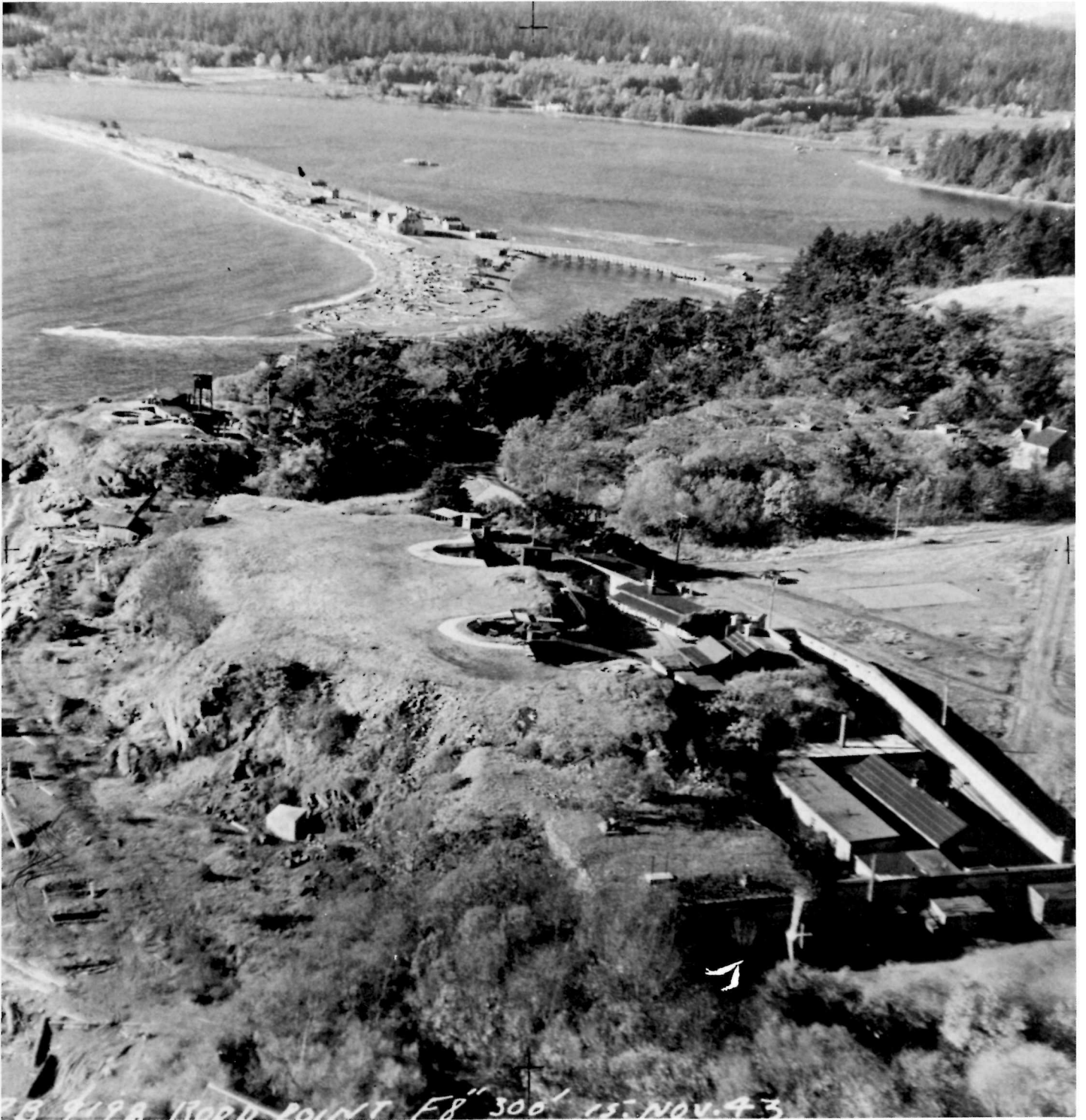

- 16 Lower Battery around 1937. Towards the end of their stay in Lower Battery, the 6-inch disappearing guns were held in the up position as this photograph shows. Visible just over the barrel of the 6-inch gun in the foreground is the QF 6-inch mounted in front of the battery with (apparently) its sub-calibre gun mounted on top. (Fort Rodd Hill National Historic Park Photograph Collection.)



- 17 Lower Battery from the air, 1944. The 40 mm Bofors gun in no. 2 gun position is clearly shown in this photograph. (Fort Rodd Hill National Historic Park Photograph Collection.)



- 18 Point Pleasant Battery, Halifax, N.S., 1903. This battery was constructed at about the same time as Rodd Hill and is, in many respects, similar. Note the use of steel beams in the roofs of the shelter and the small buildings on the flanks of the battery. (Public Archives of Canada.)

—HALIFAX NS—
—POINT PLEASANT BATTERY—

—SHEET NO. 1—

SCALE 5 FEET TO AN INCH R.F.S.

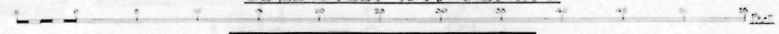

NOTE
 The ground shown shows the
 high water mark
 of the sea

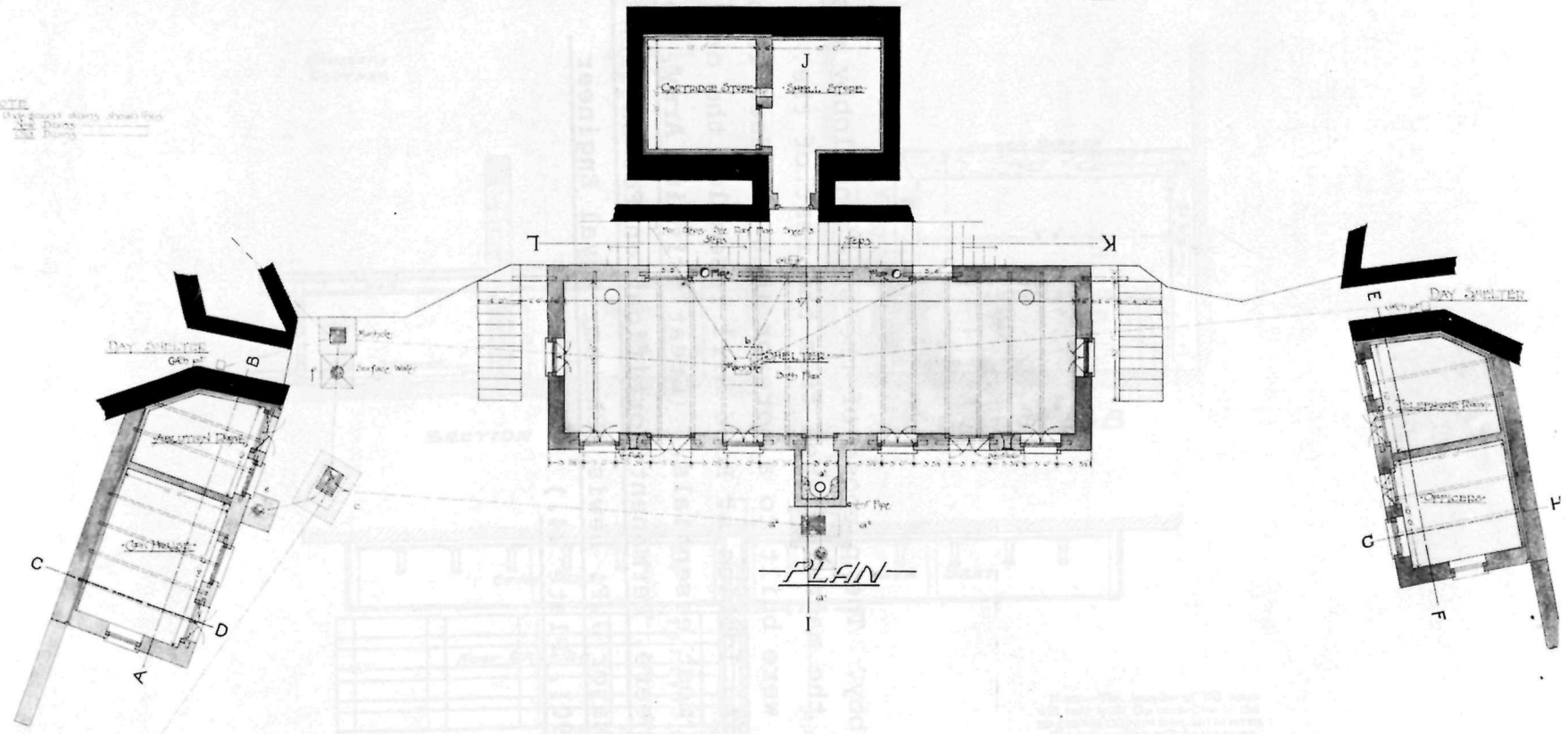

—PLAN—

583

II

L. L. ...
 B.D. G.P. RE
 D.C.S.
 4A-26-2-B

259

- 19 A shifting Lobby. The purpose of the shifting lobby was the separation of the magazine area from the rest of the battery. All were built to a more or less standard layout, and the shifting lobbies at Rodd Hill resembled the one shown here in most essentials. (Great Britain, Army, Corps of Royal Engineers, Permanent Fortification For English Engineers by Major J.F. Lewis [Chatam: Royal Engineer Institute, 1890], Plate 24.)

SHIFTING LOBBY
 WITH BARRIER, SEATS, FOOT GRATING AND
 RAILS WITH PEGS

PLATE XXIV

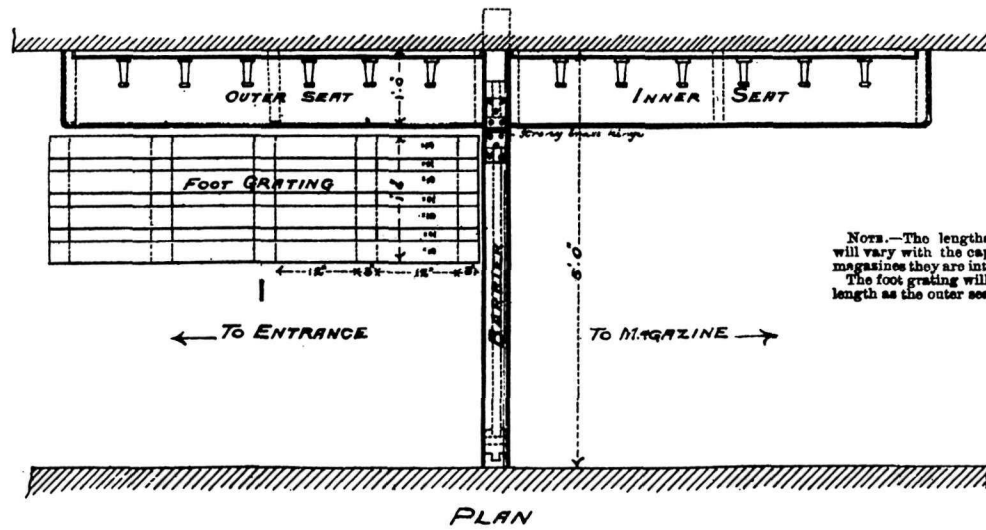
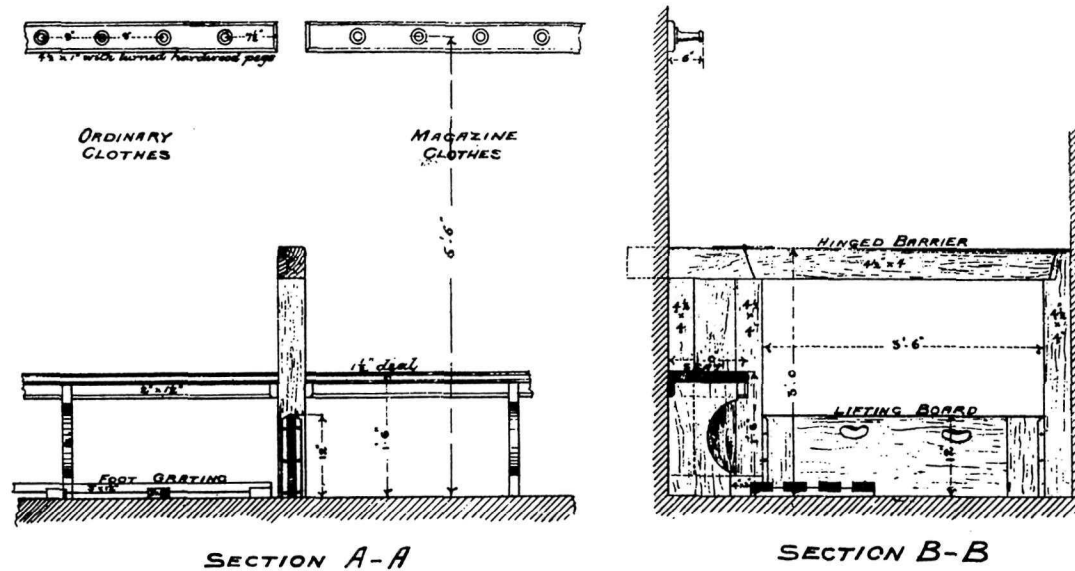

PLAN
 Scale 2 feet to 1 inch.

- 20 8 Cwt. Wrought Iron Davit. A standard pattern davit.
(Great Britain, Army, Corps of Royal Engineers, Permanent
Fortification for English Engineers by Major J.F. Lewis
[Chatam: Royal Engineer Institue, 1890], Plate 29.)

8. Cwt. WROUGHT IRON DAVIT
GALVANIZED.

PLATE XXIX.

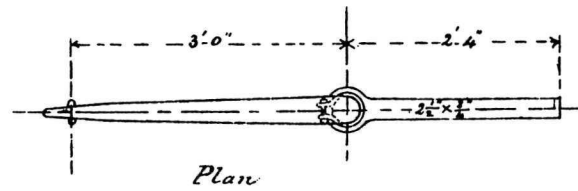
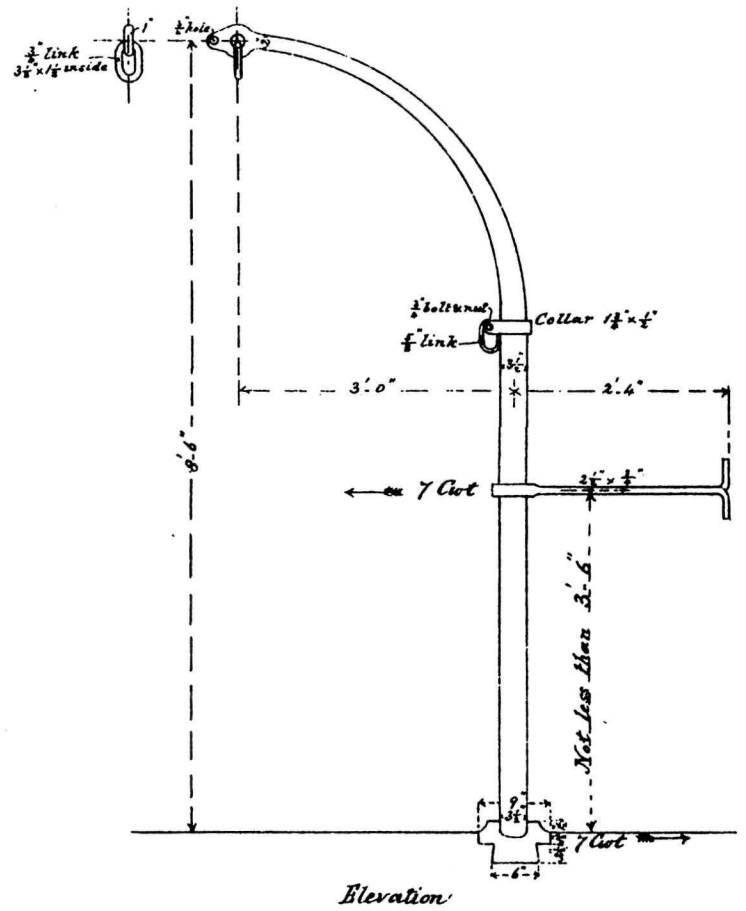

Scale 3 feet to 1 inch.

- 21 Carriage, Garrison, Disappearing, B.L. 6 In. Mark IV. The Rodd Hill carriage. At Rodd Hill, however, a Mark VI gun was mounted. (Great Britain, War Office, Treatise on Military Carriages and Stores Connected with Them [London: HMSO, 1902], Plate 232.)

CARRIAGE, GARRISON, DISAPPEARING, B.L. 6 IN. MARK IV.
H.P. FOR MARK IV GUN.

SCALE $\frac{1}{25}$

ELEVATION.

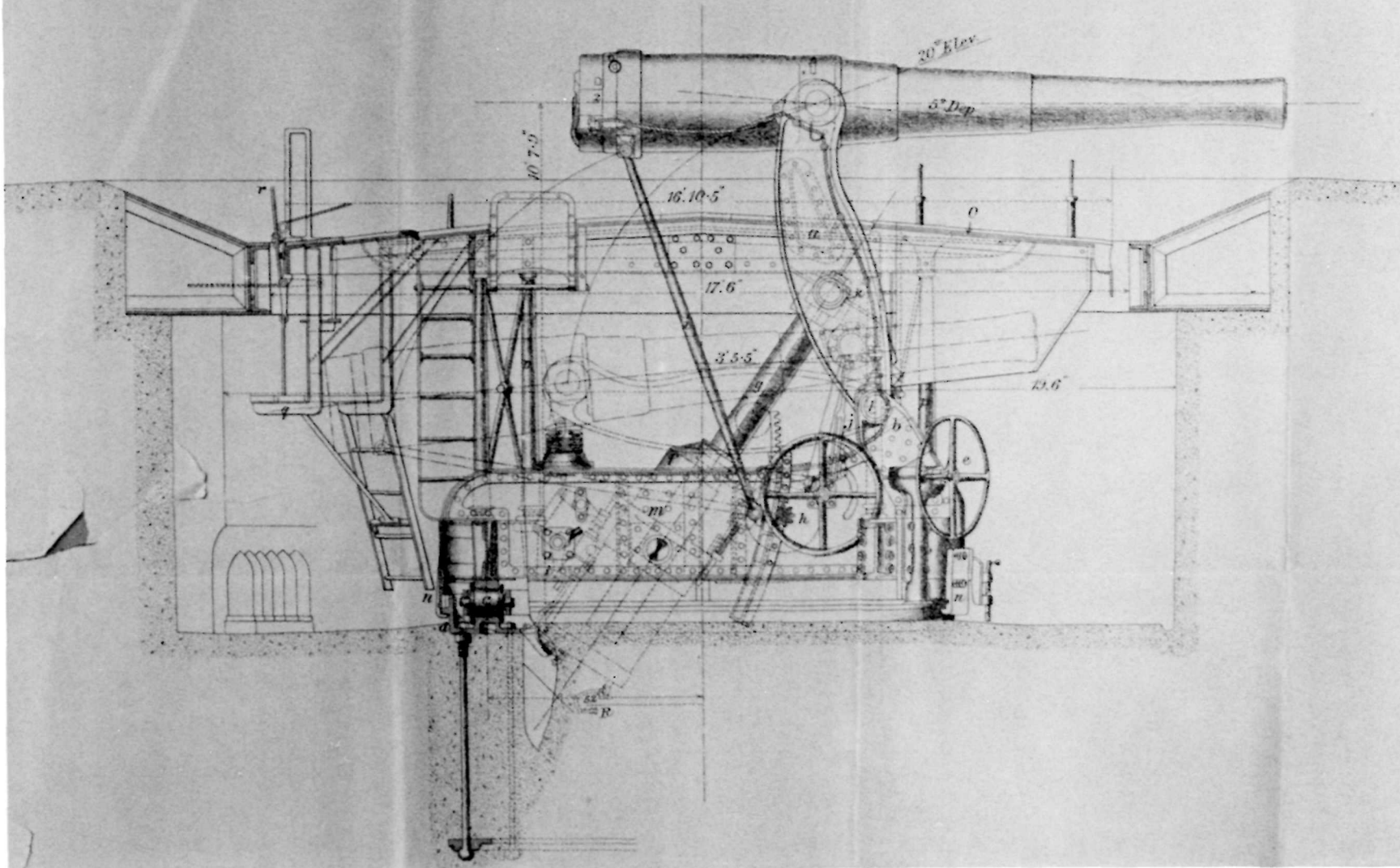

- 22 Carriage, Garrison, Disappearing. The same carriage as in the preceding figure, viewed from above. (Great Britain, War Office, Treatise on Military Carriages and Stores Connected with Them [London: HMSO, 1902], Plate 233.)

CARRIAGE, GARRISON. DISAPPEARING. B. L. 6 IN. MARK IV.

H. P. FOR MARK IV GUN.

PLAN.

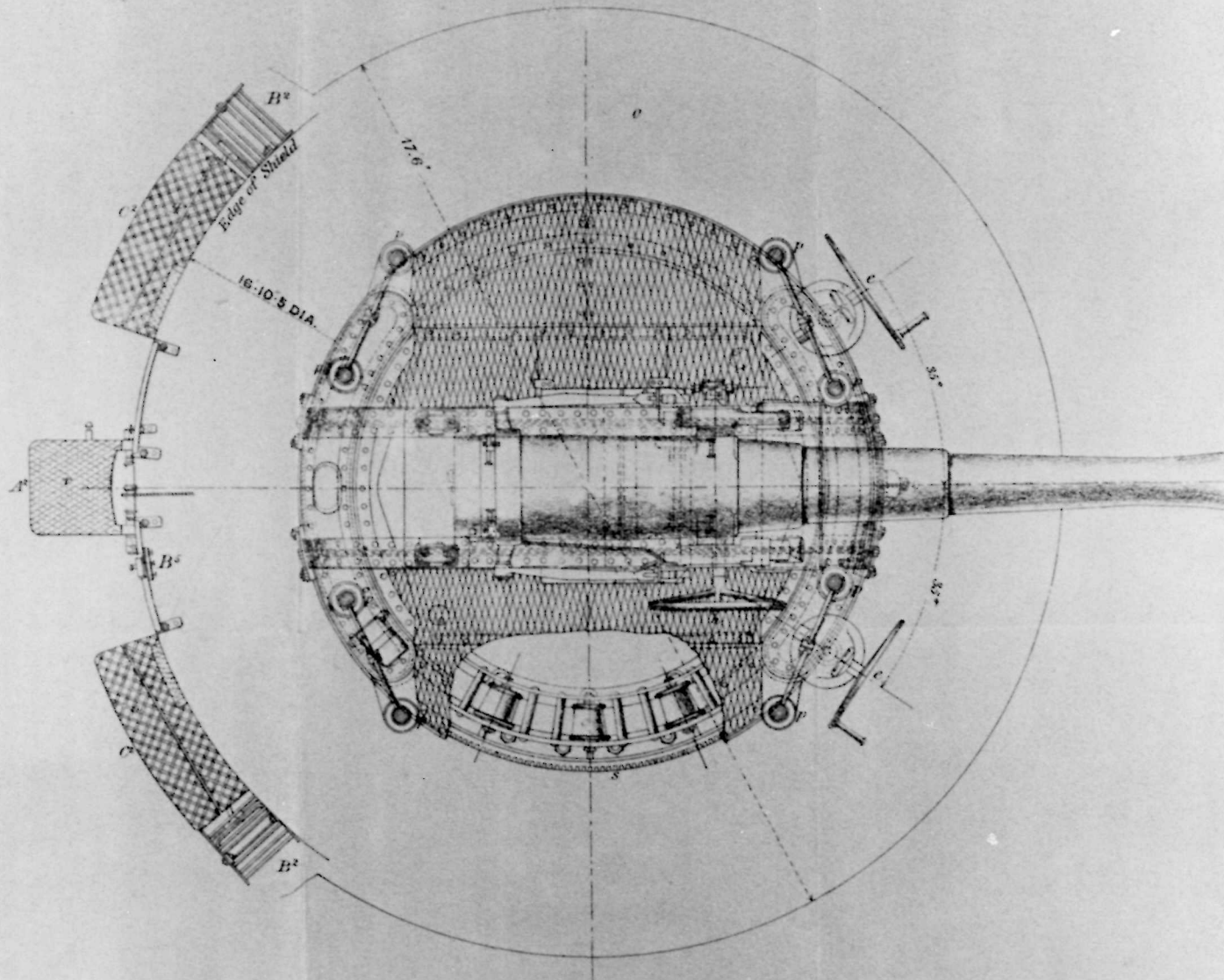

- 23 Carriage Garrison Disappearing. One of the three disappearing carriages at Rodd Hill. The gun is a 6-inch Mark VI. (Fort Rodd Hill National Historic Park Photograph Collection.)

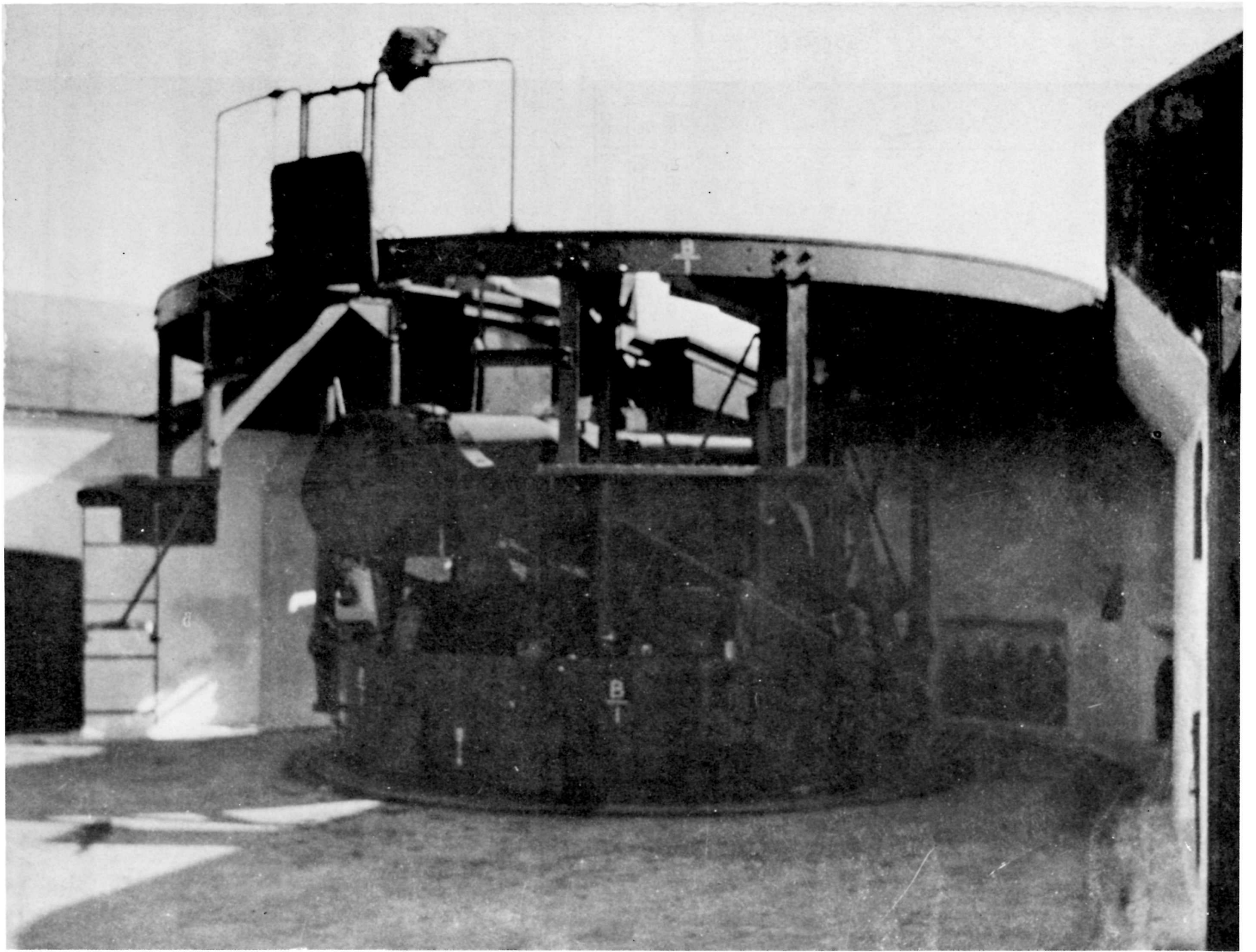

- 24 Recoil Cylinder. The most important part of the mechanism of the disappearing carriage. (Great Britain, War Office, Handbook for the 6-inch B.L. and B.L.C. Guns and Mountings, &c. [London: HMSO, 1904], Plate 53.)

CARRIAGE, GARRISON, DISAPPEARING, B. L., 6 INCH, MARK IV. (HYDRO PNEUMATIC)

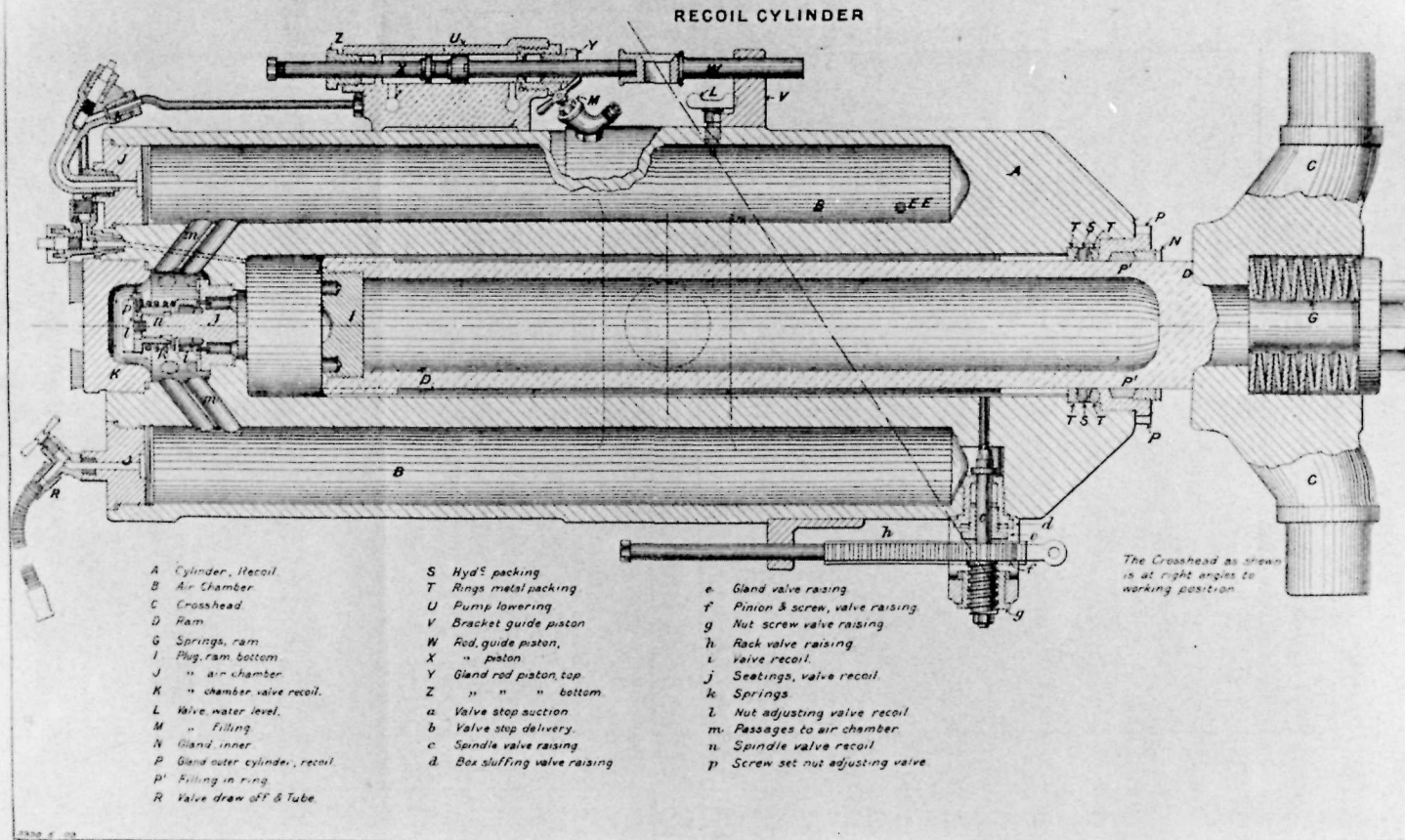

- 25 Connections: Pressure Gauges. (Great Britain, War Office, Handbook for the 6-inch B.L. and B.L.C. Guns and Mountings, &c. [London: HMSO, 1904], Plate 53.)

CONNECTION, PRESSURE GAUGES.

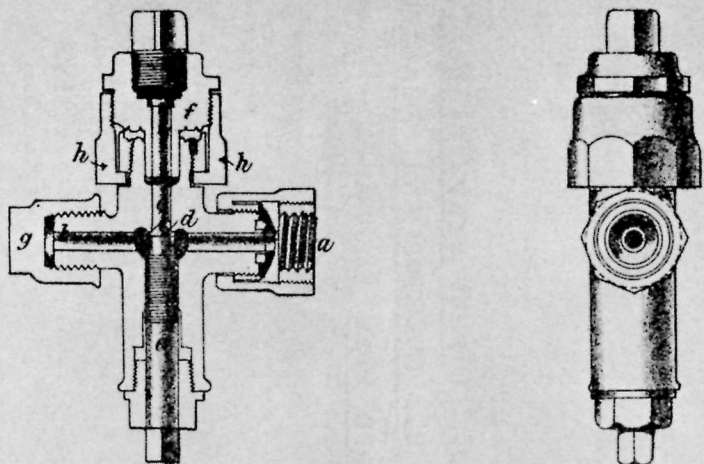

9827 5.03

E. Weiler & Graham, Ltd. Litho London

Plate XVIII.

- 26 Gauges, Pressure. (Great Britain, War Office, Handbook for 6-inch B.L. and B.L.C. Guns and Mountings, &c. [London: HMSO, 1904], Plate 61a.))

GAUGES, PRESSURE.

N^o 2.

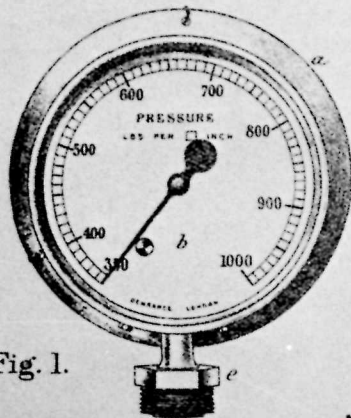

N^o 3.

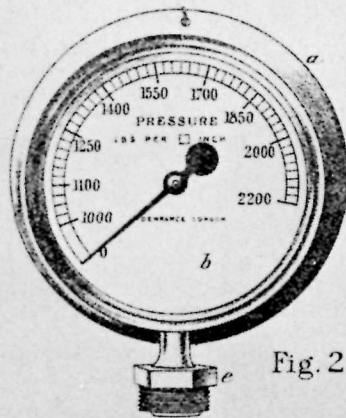

N^o 4.

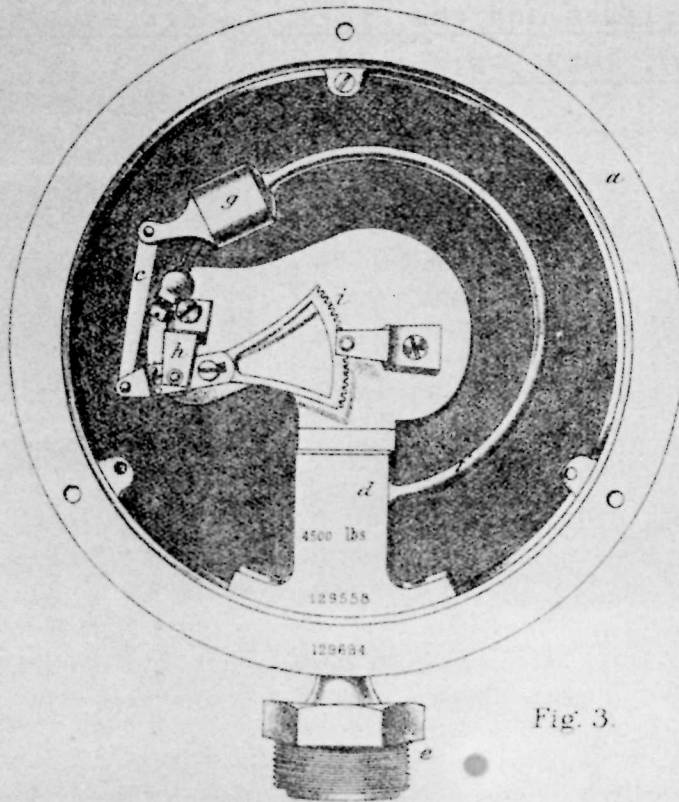

- 27 Raising Valve. (Great Britain, War Office, Treatise on
Military Carriages and the Stores Connected with Them
[London: HMSO, 1902], Plate 236.)

See plate 335.

Plate 336

**CARRIAGE GARRISON B.L. DISAPPEARING
6 INCH B.L. MARKS II TO IV.**

RAISING VALVE.

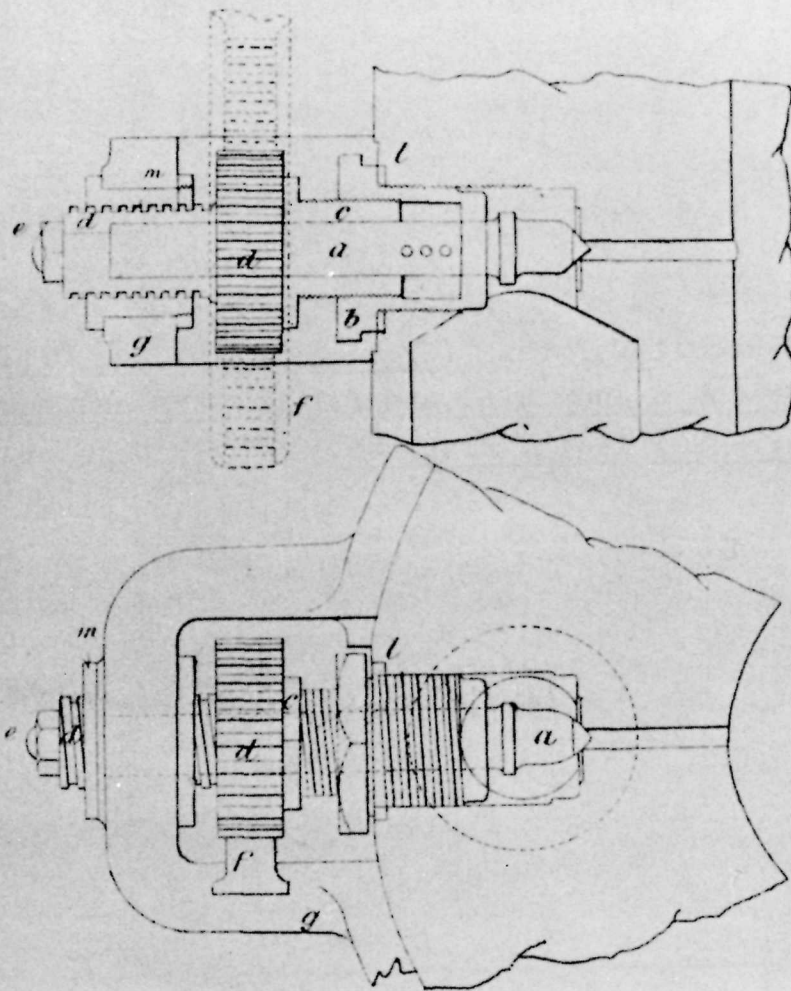

NOTE. Metal seating for valve
spindle not shown.

- 28 Raising and Recoil Valves. (Great Britain, War Office,
Handbook for the 6-inch B.L. and B.L.C. Guns and Mountings,
&c. [London: HMSO, 1904], Plate 49.))

CARRIAGE GARRISON, DISAPPEARING B.L., 6 INCH. MARKS II TO IV.

RAISING VALVE. Fig. II.

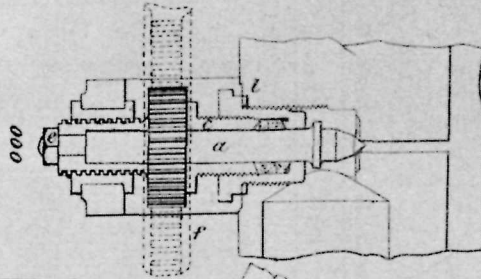

See Plate LIII also

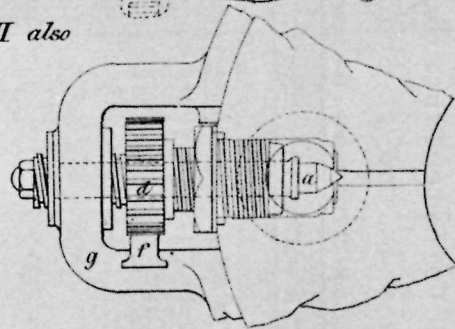

l. Lead Washers.

RECOIL VALVE. Fig. I.

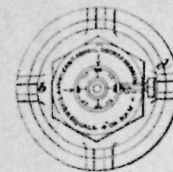
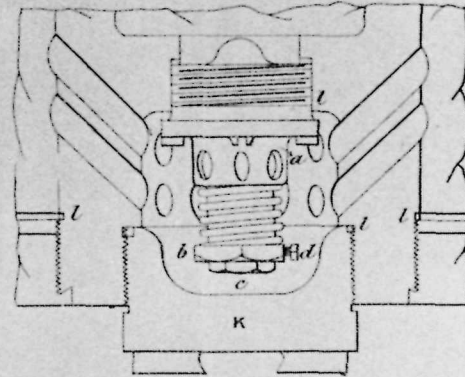

PLAN WITH "b" REMOVED.

- 29 14 lb. 12 oz. Cordite Cartridge. One of the standard Cordite charges in use at Rodd Hill. (Great Britain, War Office, Handbook for the 6-inch B.L. and B.L.C. Guns and Mountings, &c. [London: HMSO, 1904], Plate 49.)

CARTRIDGE, B.L.. 6 INCH, 14 LB. 12 OZ., CORDITE.. SIZE 20, MARK II.
SILK CLOTH. MARKS IV TO VI GUNS.

SCALE $\frac{1}{4}$.

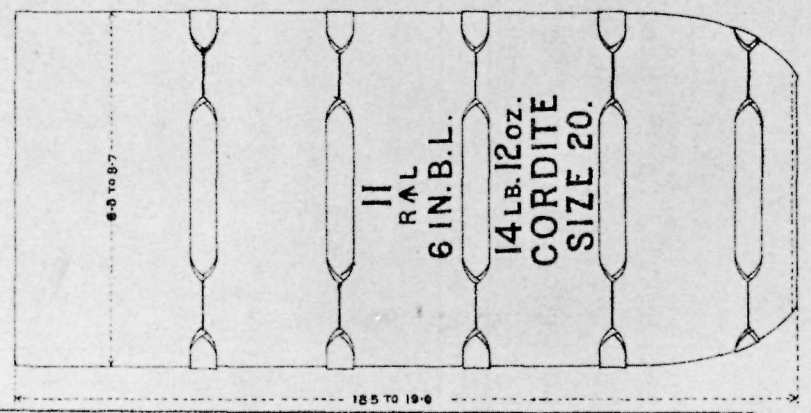
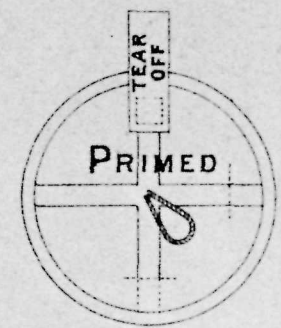

Plate LXIX

3870 & 63

- 30 12 lb. E.X.E. Cartridge. Cartridges of this type were authorized for use in forts armed with 6-inch guns. There is no proof that any were ever used at Rodd Hill. (Great Britain, War Office, Handbook for the 6-inch B.L. and B.L.C. Guns and Mountings, &c. [London: HMSO, 1904], Plate 48.)

Plate LXVIII

CARTRIDGE, B.L., 6 INCH, 12 LB. E.X.E., MARK I.
(SILK CLOTH, ¼ CHARGE FULL.)

Scale ¼

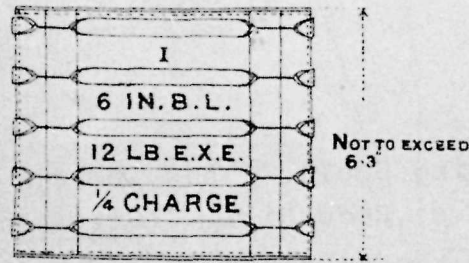

ELEVATION.

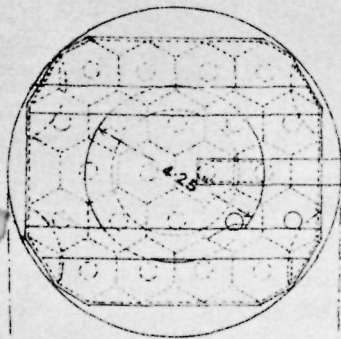

PLAN.

- 31 Armour Piercing Shell. This was the most common type of shell in use at Rodd Hill. (Great Britain, War Office, Handbook for the 6-inch B.L. and B.L.C. Guns and Mountings, &c. [London: HMSO, 1904], Plate 72.)

Plate LXXII.

SHELL B.L. Q.F. OR Q.F.C. ARMOUR PIERCING, 6 INCH GUN (MARK III)

SCALE $\frac{1}{4}$.

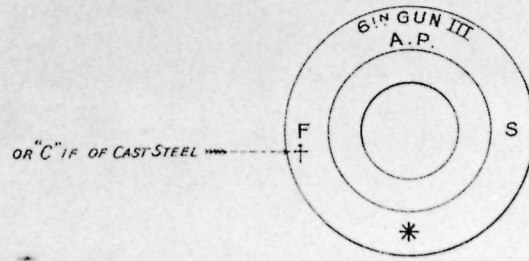
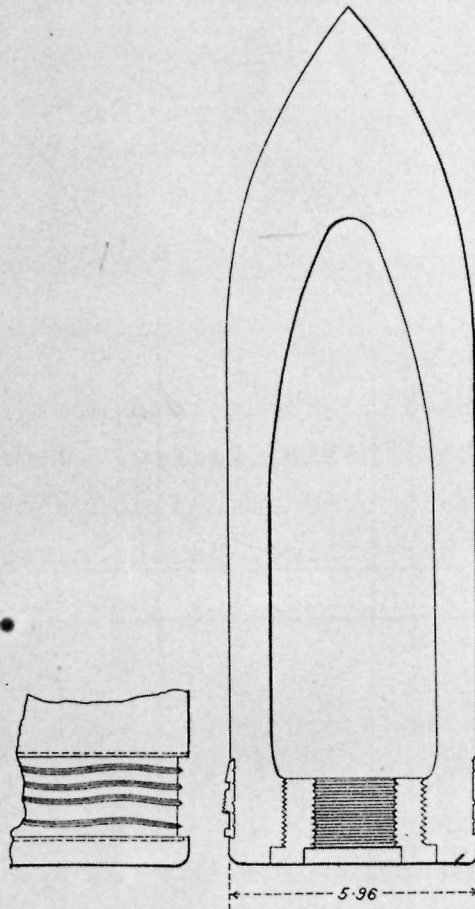

- 32 Common Lyddite Shell. The second most common type of shell in use during the Imperial Period. Lyddite shells were stored in the small arms ammunition store in Lower Battery. (Great Britain, War Office, Handbook for the 6-inch B.L. and B.L.C. Guns and Mountings, &c. [London: HMSO, 1904], Plate 74.)

Plate LXXIV

SHELL B.L.Q.FOR Q.F.C. LYDDITE COMMON 6 INCH GUN, MARK IV

SCALE $\cdot \frac{1}{4}$.

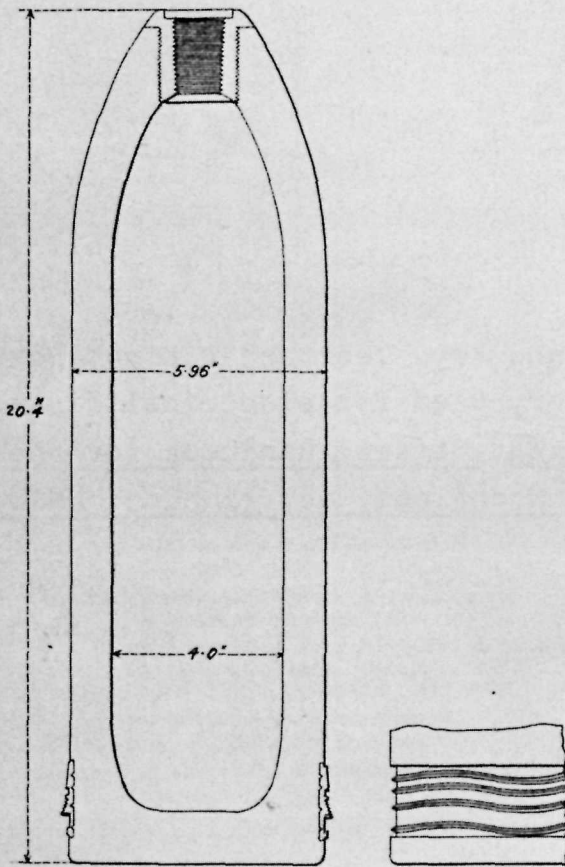

3920 K. 03.

Weiler & Graham Ltd. Litho London

- 33 Battery and Key, Test and Firing, Box. The box contained the battery used for electrical firing of the gun. (Great Britain, War Office, Handbook for the 6-inch B.L. and B.L.C. Guns and Mountings, &c. [London: HMSO, 1904], page 84.)

84

A brass plug with ebonite head is provided for completing the circuit through the plug socket when desired; it is carried in the holder when not in use.

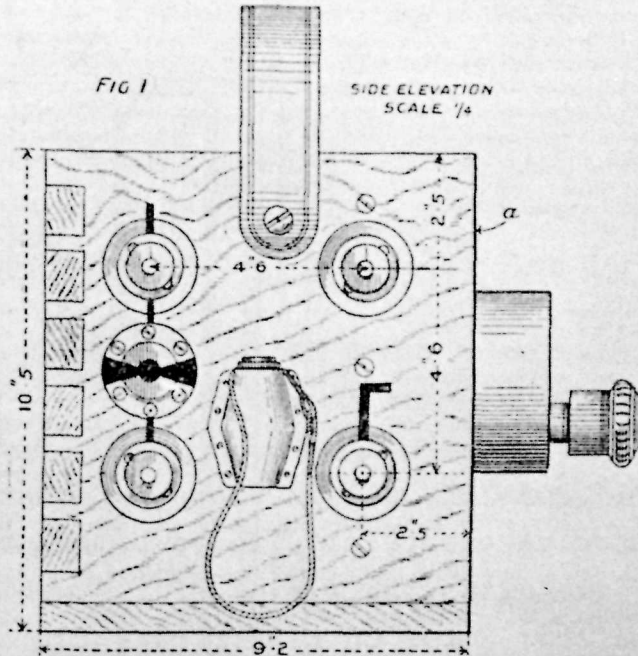

A diagram of internal and external connections, as shown in Fig. 2, is fixed at *a*.

To clearly indicate the terminals to which electric firing leads are to be connected, "segments" of celluloid are fixed to the battery as follows:—

Coral	Near the right hand lower terminal.
White	Near the right hand upper terminal.
Black	Near the left hand upper terminal.
Turquoise	Near the left hand lower terminal.

Similar coloured "sleeves" of celluloid are attached in a convenient position near the ends of the leads (see Leads, page 86).

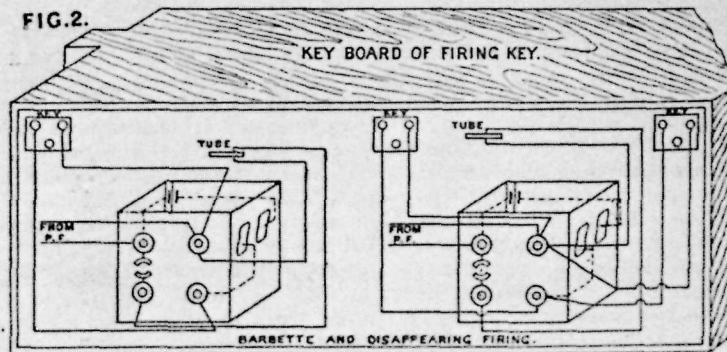

- 34 A Leclanché cell. A "C" cell is shown. Leclanché cells were used to provide electricity for a number of operations at the battery including the firing of the gun. (Great Britain, War Office, Notes on Electricity for the Use of Garrison Artillery [London: HMSO, 1907], p. 48.)

high and 6 inches in diameter. Fig. 11 shows a section of the cell, whilst Fig. 12 gives the external appearance of the Leclanché "G" type; a cell generally similar to the "C" except in dimensions.

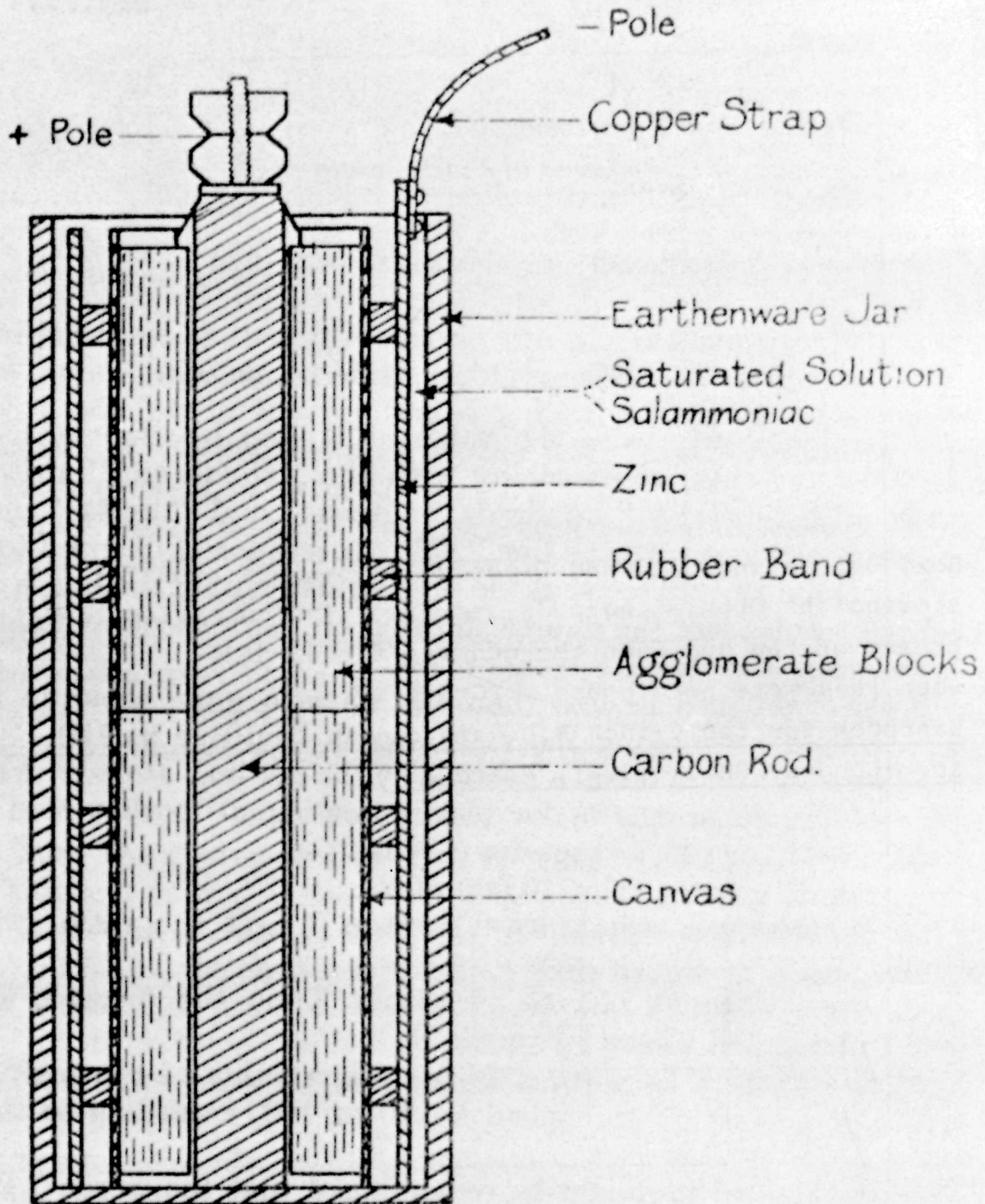

FIG. 11.—Cell, Leclanché, "C" (section).

The zinc is amalgamated to prevent *local action*, and riveted and soldered to it is a flexible copper strip providing a means of connection to another cell, the strip and its junction with the zinc being covered with protective varnish.

- 35 Box, Obturating Pads and Discs. The box was used for storing the Obturating pads and discs (which sealed the breach of the gun when the gun was fired) under pressure when they were not in use. (Great Britain, War Office, Handbook for the 6-inch B.L. and B.L.C. Guns and Mountings, &c. [London: HMSO, 1904], Plate 13.)

BOX, OBTURATING PADS & DISCS, B.L. 6 IN. MKS III, IV & VI;
AND B.L.C. 6 IN. GUNS (MK III) | C.

SCALE $\frac{1}{4}$.

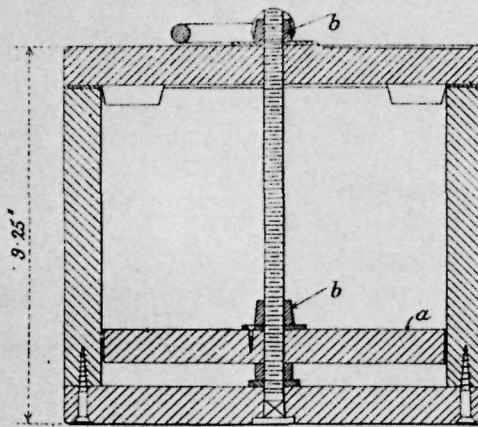

SECTIONAL ELEVATION.

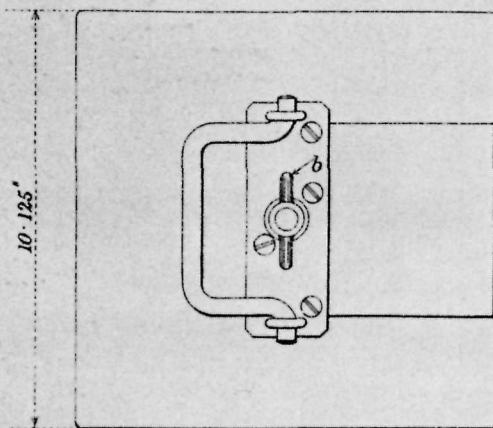

PLAN.

- 36 Tube Extractor (P and P Special). Both were used for extracting percussion tubes from the vent of the gun. (Great Britain, War Office, Handbook for the 6-inch B.L. and B.L.C. Guns and Mountings, &c. [London: HMSO, 1904, Plate 14.]

Plate XVI

EXTRACTOR, TUBE, P. (MARK I)
STEEL VENT SEALING, PERCUSSION

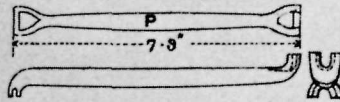

EXTRACTOR, TUBE, P. SPECIAL (MARK I)
STEEL VENT SEALING PERCUSSION.

SCALE $\frac{1}{4}$

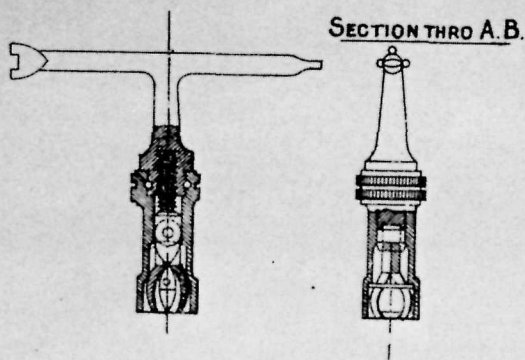

3920 A. 09.

E. Weller & Grahams, Ltd. Litho. London.

19 London

- 37 Percussion Base Fuze. These were used with the armour piercing shells. (Great Britain, War Office, Handbook for the 6-inch B.L. and B.L.C. Guns and Mountings, &c. [London: HMSO, 1904], Plate 79.)

FUZE, PERCUSSION, BASE, LARGE, N^o II, (MARK II)

METAL; ONE IN A TIN CYLINDER

FULL SIZE

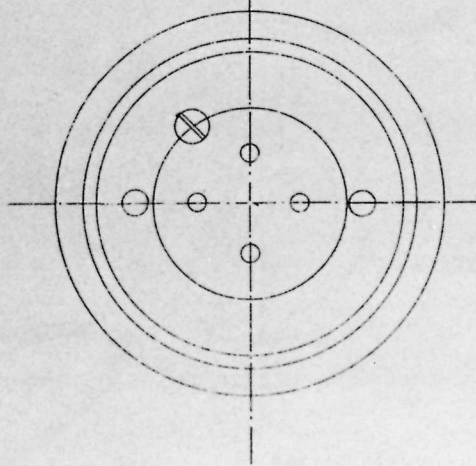
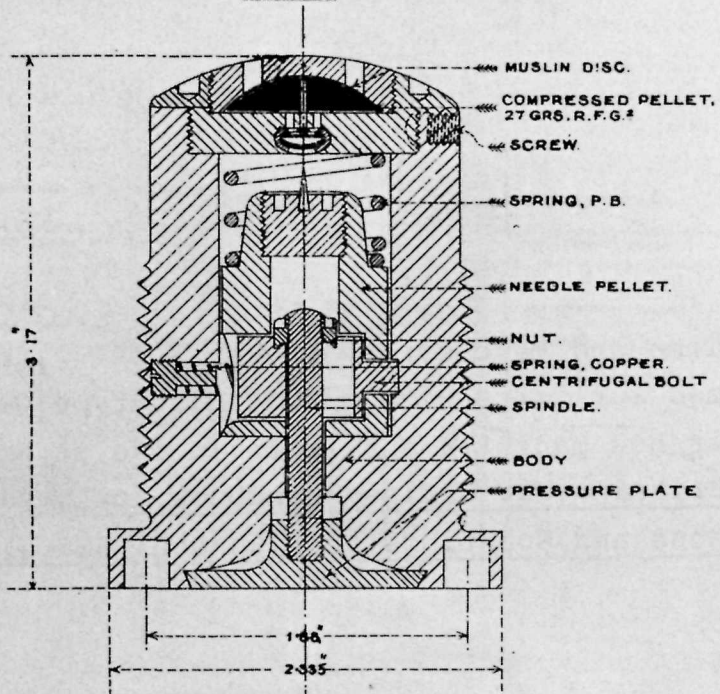

- 38 Fuze. Time and Percussion Middle N054. These were authorized for forts with a Rodd Hill-type Ordnance. It is not clear how many (if any) were in use at Rodd Hill. (Great Britain, War Office, Handbook for the 6-inch B.L. and B.L.C. Guns and Mountings &c. [London: HMSO, 1904], Plate 82.)

FUZE, TIME, AND PERCUSSION, MIDDLE, N^o 54, MARK III.

METAL I IN A TIN CYLINDER.

Full Size.

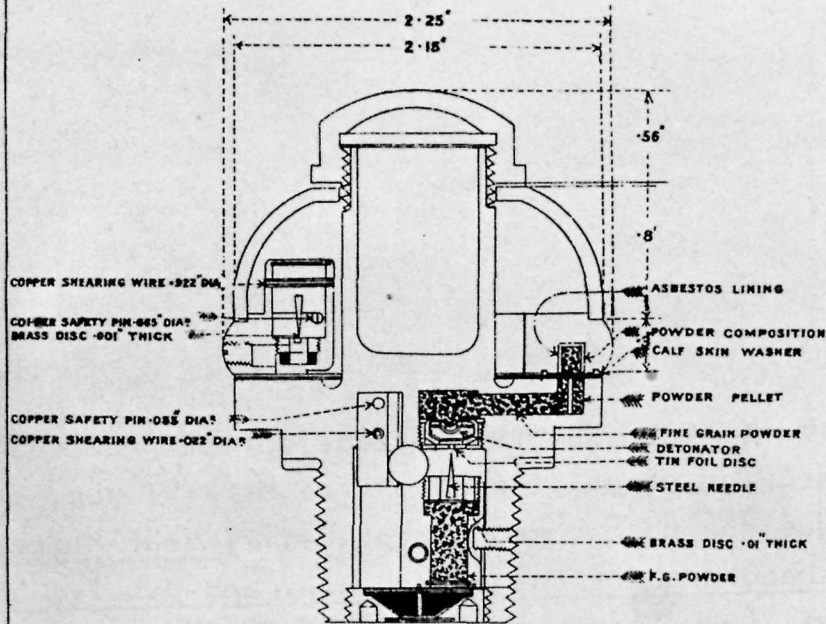

SECTION AT A. A

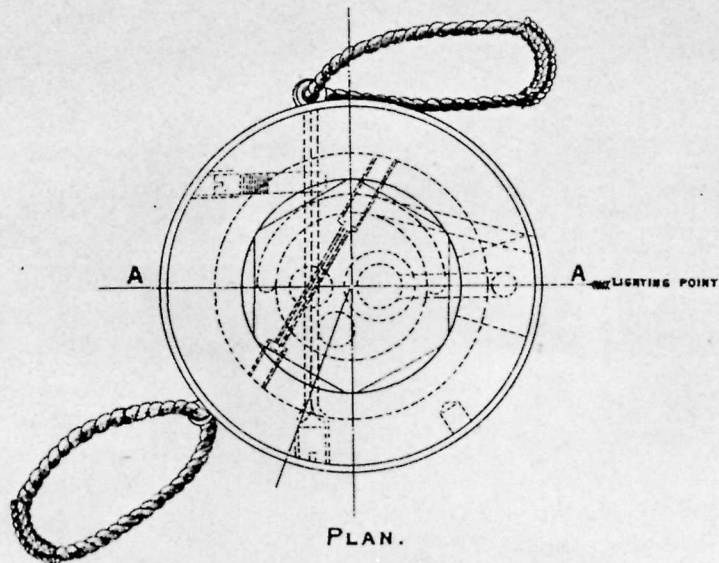

- 39 Percussion Locks. The "H" percussion lock (above) was authorized for manual firing of the Mark VI gun. Electrical firing was the most common practice. (Great Britain, War Office, Handbook for the 6-inch B.L. and B.L.C. Guns and Mountings, &c. [London: HMSO, 1904], Plate 3.)

ORDNANCE, B. L., 6 INCH, MARKS III, IV, VI, & II
 DRILL LOCK, PERCUSSION: FOR DRILL & PRACTICE GUNS.

ORDNANCE, B. L., LOCK, PERCUSSION, H. (MARK I).
 FOR MARKS IV & VI.

SCALE $\frac{1}{2}$.

FIG. 1.

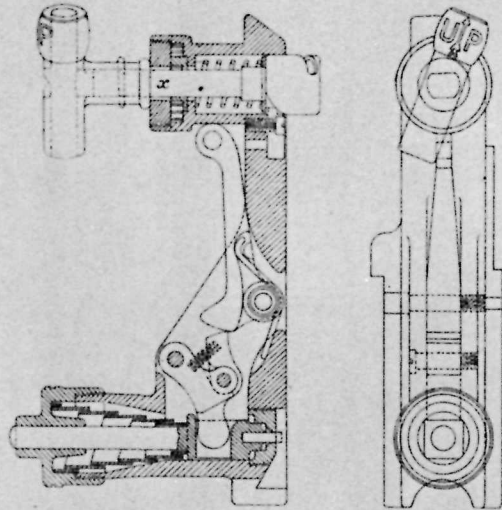

SCALE $\frac{3}{8}$.

FIG. 2.

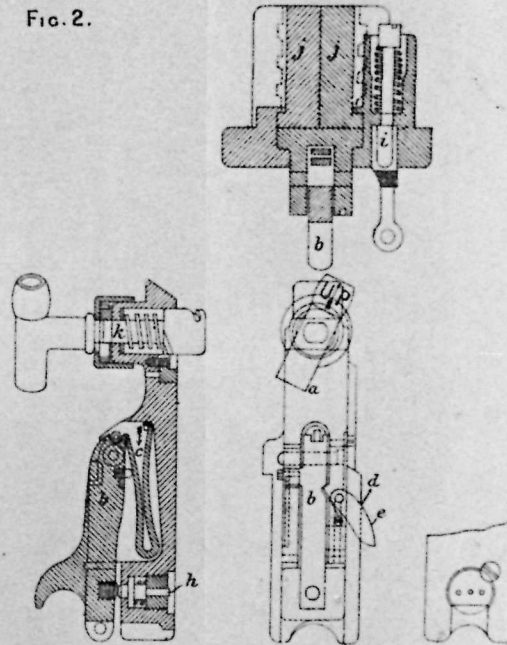

NOTE. - Locks of this description (Fig 2) were originally fitted with sliding hammer guards which, when they became worn, were found liable to cause missfires. These guards have been removed, and locks so altered are distinguished by a " * " added to the Mark.

RONALD LOVATT

40 Pump, Air, Double. Top Plan. The pump was used with the Rodd Hill guns. (Great Britain, War Office, Handbook for the 6-inch B.L. and B.L.C. Guns and Mountings &c. [London: HMSO, 1904], Plate 15.))

PUMP, AIR, DOUBLE, MARK I.

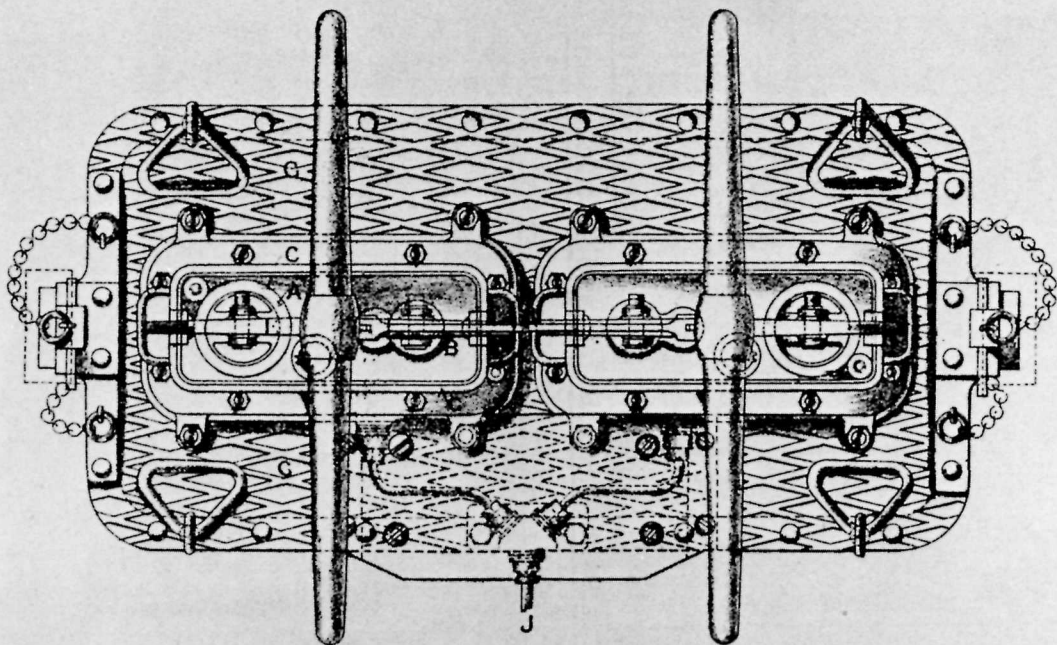

TOP PLAN.

Plate IX.

E. Weller & Graham's Ltd. Lichfield, London.

1/2 in. = 1 in.

- 41 Pump, Air, Double. Elevation. (Great Britain, War Office, Handbook for the 6-inch B.L. and B.L.C. Guns and Mountings, &c. [London: HMSO, 1904], Plate 14.)

PUMP, AIR, DOUBLE, MARK I.

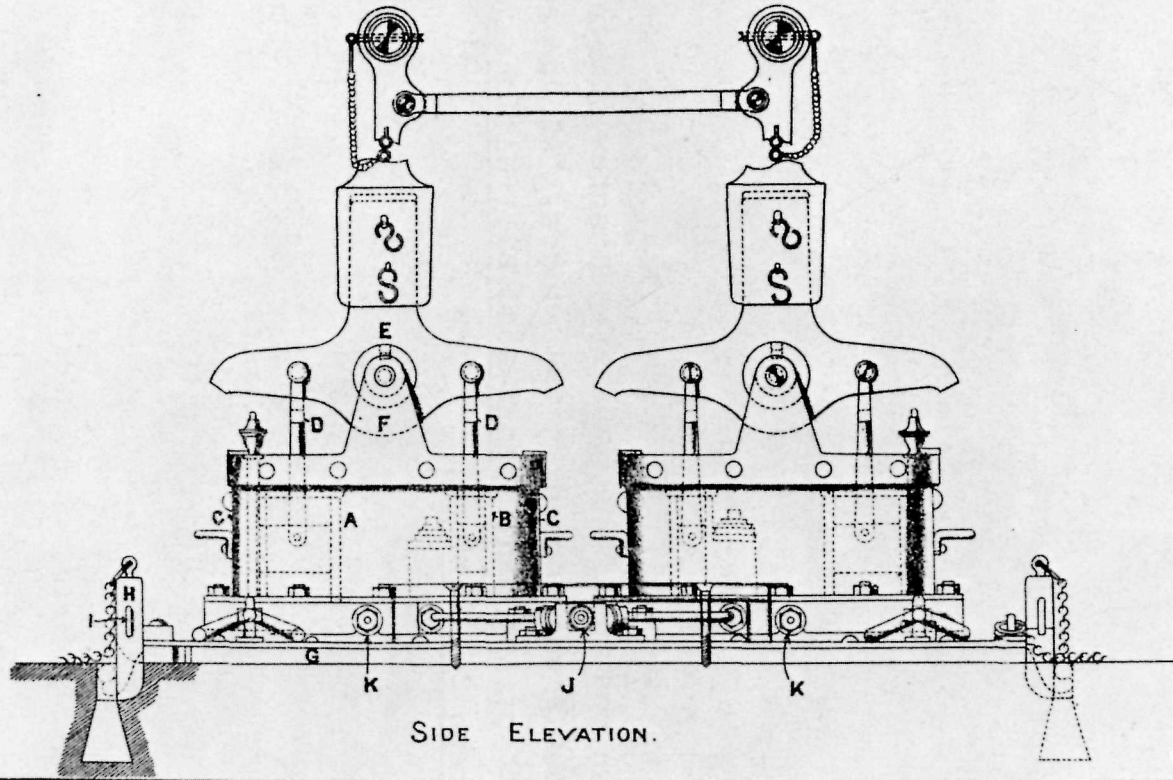

W. & A. G. & Co.

Muller & Co., Ltd. London

Plate LIX

42 One of the Rodd Hill Guns (ca. 1934). This shows the gun in the down position, with the breech screw removed. The pump, air, double was housed in the wooden, "A" frame structure to the left of the man. (Fort Rodd Hill National Historic Park Photograph Collection.)

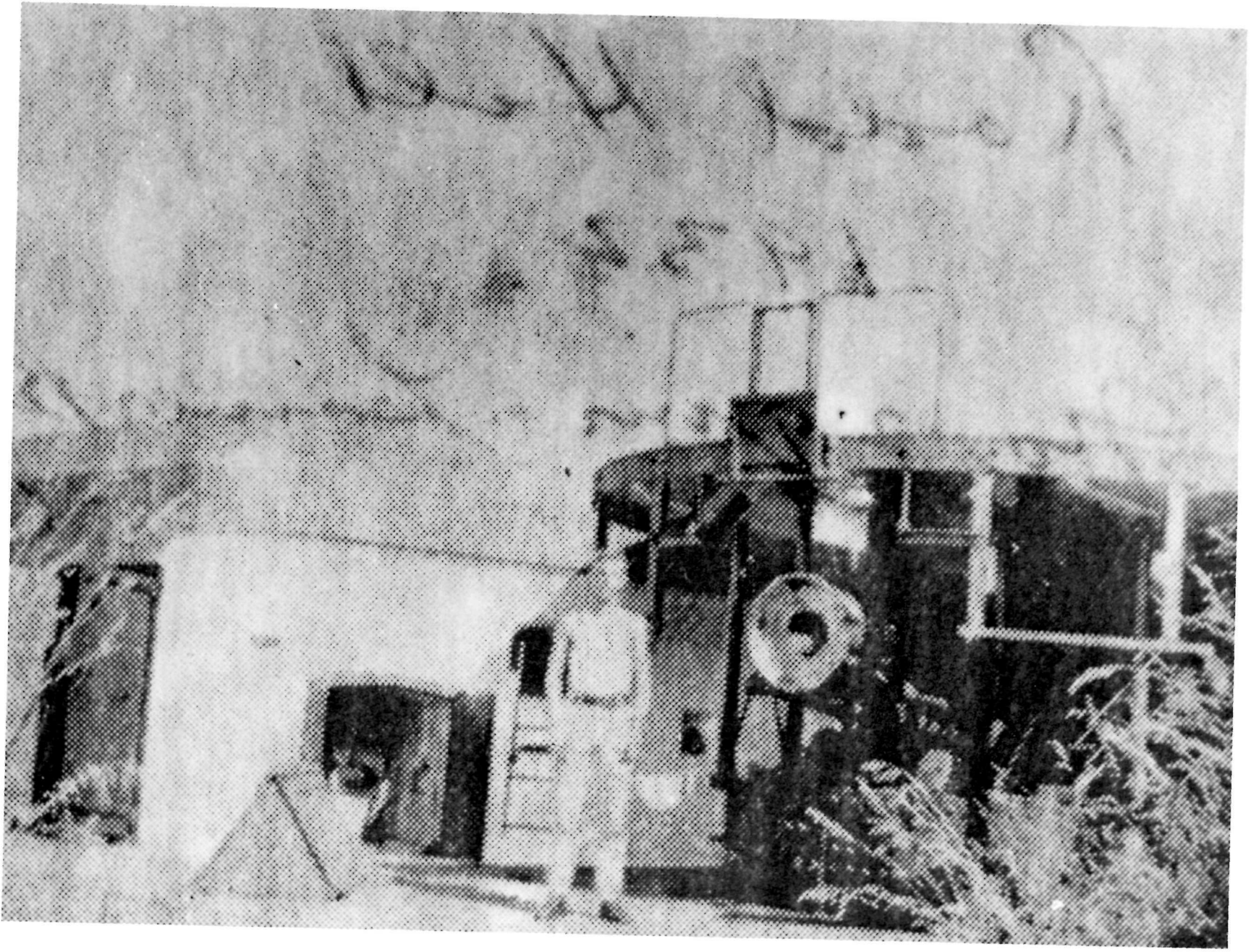

- 43 Compressed Air Reservoir. An essential part of the gun carriage equipment as the hydraulic system of the HP was notoriously leak-prone. (Great Britain, War Office, Handbook for the 6-inch B.L. and B.L.C. Guns and Mountings, &c. [London: HMSO, 1904], Plate 62.)

RESERVOIRS, COMPRESSED AIR.

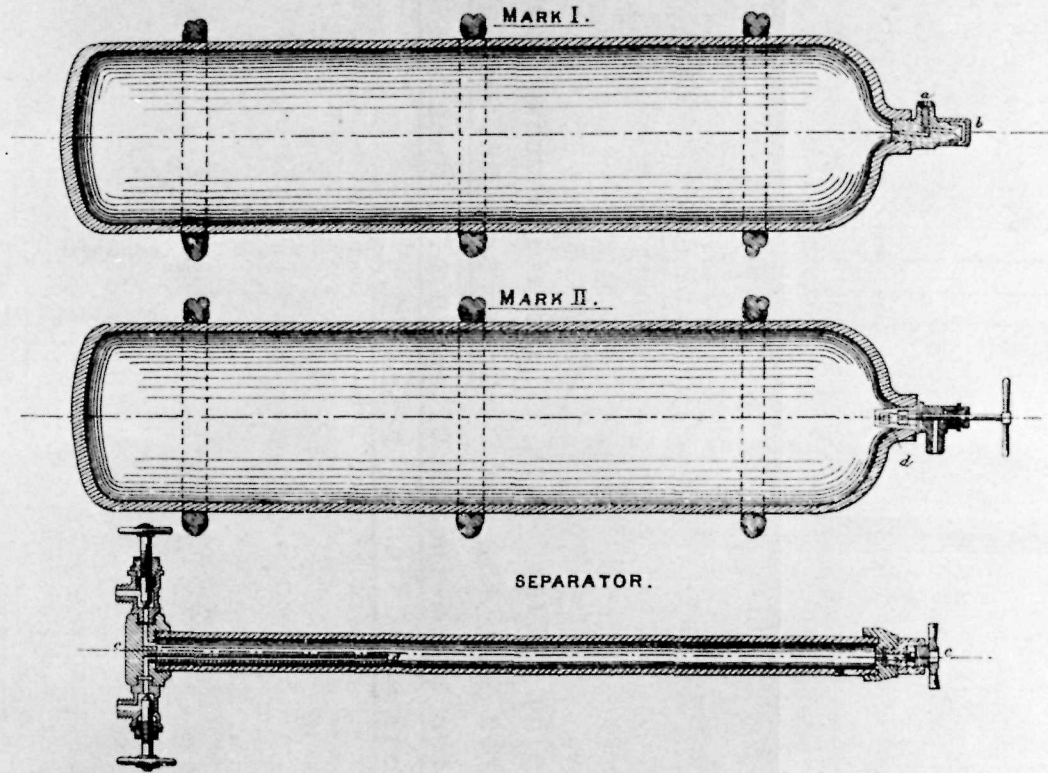

- 44 Morris Aiming Rifle. This illustration shows how the Aiming rifle tilted into the gun. (Great Britain, War Office, Handbook for the 6-inch B.L. and B.L.C. Guns and Mountings, &c. [London: HMSO, 1904], Plate 18.)

RIFLE, AIMING, 1 INCH, MORRIS, B.L. | L |

EIGHTH SCALE.

GENERAL ARRANGEMENT OF RIFLE IN GUN.

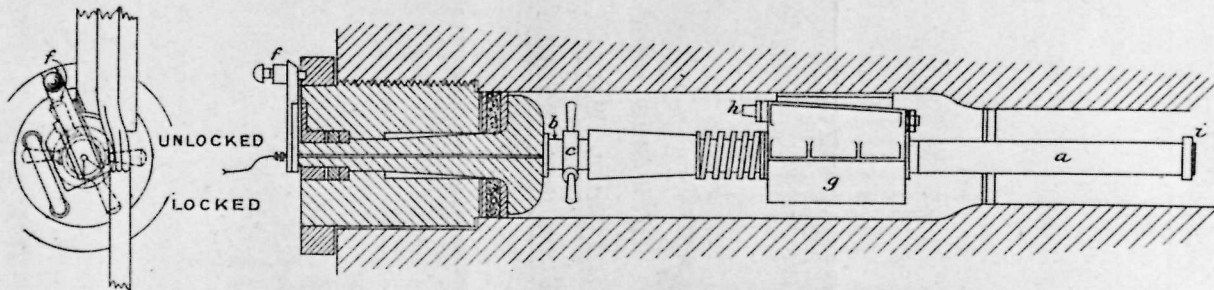

SECTION SHOWING "TUBE" INSIDE RIFLE.

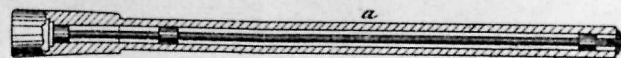

HALF SCALE

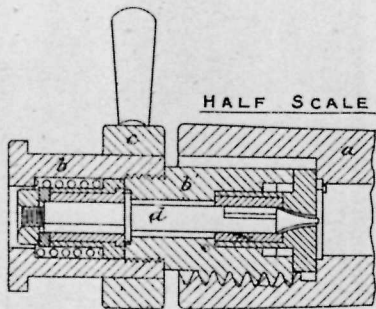

PART SECTION THRO: EXTRACTOR.

HALF SCALE.

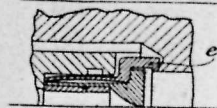

- 45 Electric Vent Sealing tube. This was used for electrical firing of the gun. (Great Britain, War Office, Handbook for the 6-inch B.L. and B.L.C. Guns and Mountings, &c. [London: HMSO, 1904], Plate 83.)

TUBE VENT SEALING, ELECTRIC, P. MARK VII.

BRASS.

FULL SIZE.

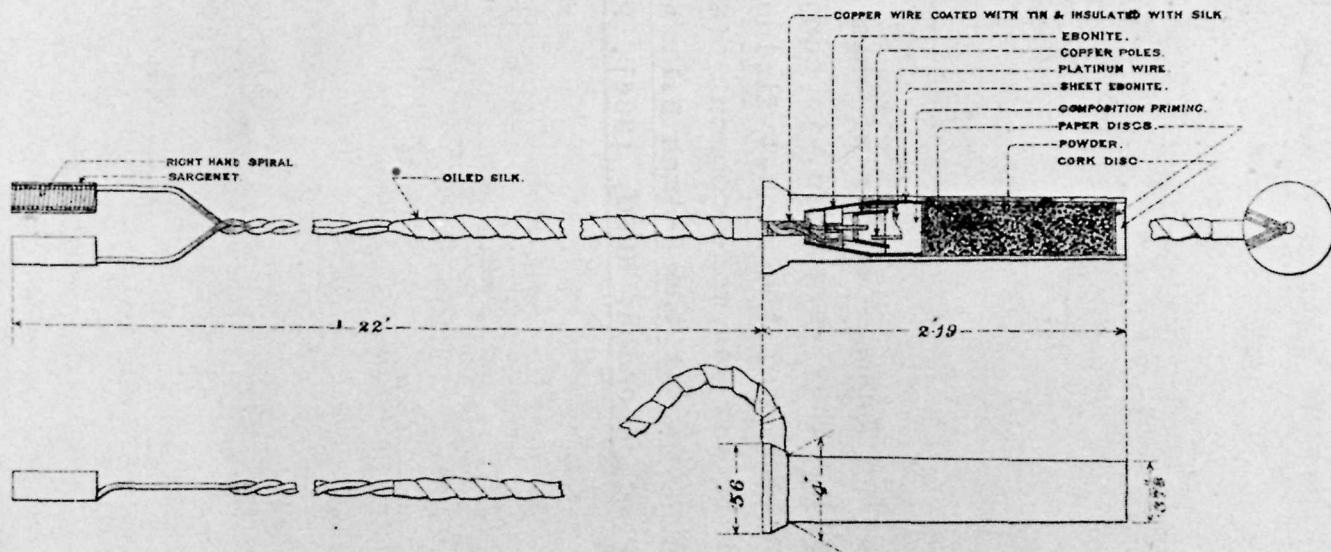

Plate XXXVII

3025 6 105

WALTON & GORHAM LTD LONDON

- 46 Two Percussion Tubes. Either of them could have been in use at Rodd Hill. They were used, in conjunction with the "H" Percussion Lock, for the manual firing of the gun. Electrical firing was more common. (Great Britain, War Office, Handbook for the 6-inch B.L. and B.L.C. Guns and Mountings, &c. [London: HMSO, 1904], Plate 85.)

Plate LXXXV.

TUBE VENT SEALING, PERCUSSION, MARK III.

BRASS.

FULL SIZE.

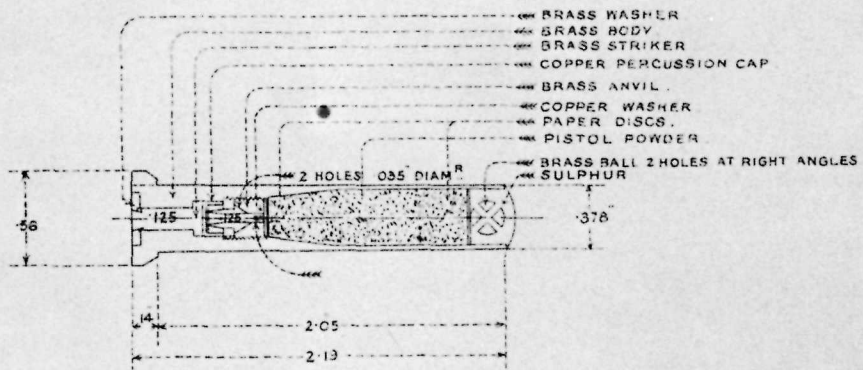

TUBE VENT SEALING PERCUSSION, MARK IV.

BRASS.

FULL SIZE.

